



# ***Workshop Equipment***

***Section 4  
Product Groups 400 - 495***

# Section 4 Contents



| <b>Description</b>                   | <b>Group</b> | <b>Page</b> |
|--------------------------------------|--------------|-------------|
| Air Gun Systems.....                 | 447          | 756         |
| Bench Shears & Folding Machines..... | 448          | 760         |
| Bin Storage Systems.....             | 404          | 678 - 681   |
| Chuck Arbors.....                    | 442          | 739         |
| Keys.....                            | 441          | 738         |
| Chucks.....                          | 440          | 736 - 738   |
| Clamping Fixtures.....               | 425          | 719 - 733   |
| CNC Tool Storage.....                | 406          | 714 - 715   |
| Coolant Hose.....                    | 447          | 757 - 759   |
| Cupboards & Lockers.....             | 405          | 682 - 689   |
| Dividing Heads/Rotary Tables.....    | 437          | 735         |
| Grinding Carriers.....               | 445          | 756         |
| Ground Flat Stock.....               | 413          | 716 - 717   |
| Key Steel.....                       | 421          | 719         |
| Lathe Chucks.....                    | 475          | 763         |
| Chuck Jaws.....                      | 490          | 768 - 770   |
| Machine Guards.....                  | 455          | 763         |
| Magnetic Chucks & Blocks.....        | 400          | 676         |
| Foreign Body Detection.....          | 400          | 677         |
| Metal Folding Machines.....          | 448          | 761         |
| Morse Taper Drill Sleeves.....       | 482          | 764         |
| Perfo Storage Systems.....           | 405          | 690 - 693   |
| Rack Clamps.....                     | 420          | 718         |
| Racking.....                         | 405          | 694 - 695   |
| Revolving & Solid Centres.....       | 488          | 765 - 767   |
| Safety Cupboards.....                | 405          | 696         |
| Silver Steel.....                    | 432          | 734         |
| Toggle Clamps.....                   | 443          | 740 - 749   |
| Tool Chests.....                     | 405          | 697         |
| Toolposts.....                       | 445          | 754 - 755   |
| Turning & Knurling Tools.....        | 450          | 762         |
| Vices.....                           | 445          | 750 - 753   |
| Wheel Dressers.....                  | 495          | 771         |
| Woodworking Benches.....             | 405          | 698 - 699   |
| Work Benches & Cabinets.....         | 405          | 700 - 713   |

**GROUP 400 MAGNETIC CHUCKS & BLOCKS**

**KENNEDY** *Magnetic Chuck Blocks*  
QUALITY INDUSTRIAL TOOLING

For use with magnetic chucks that have parallel poles, so that the magnetic field can be extended to hold awkwardly shaped workpieces. Supplied in matched pairs. Machinable.

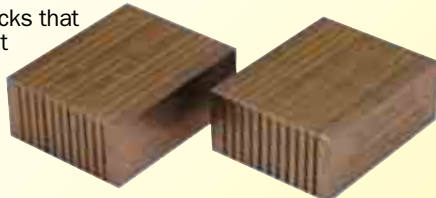

| Dimensions<br>W x L x H | Weight<br>each | Order Code<br><b>KEN-400</b> | List<br>Price/1 | Offer<br>Price/1 |
|-------------------------|----------------|------------------------------|-----------------|------------------|
| 60 x 75 x 30mm          | 1.50kg         | <b>-2500K</b>                | £102.01         | <b>£64.27</b>    |

**ECLIPSE** *Chuck Blocks*  
MAGNETICS

For use with magnetic chucks that have parallel poles, so that the magnetic field can be extended to hold awkwardly shaped workpieces. Supplied in matched and numbered pairs. Machinable.

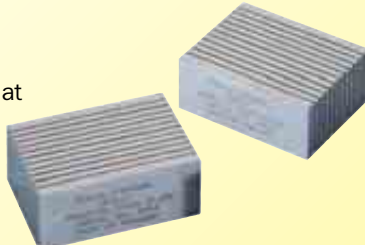

| Dimensions<br>W x L x H | Weight<br>each | Order Code<br><b>ECL-400</b> | List<br>Price/1 | Offer<br>Price/1 |
|-------------------------|----------------|------------------------------|-----------------|------------------|
| 60 x 75 x 30            | 1.45kg         | <b>-7005C</b>                | £107.11         | <b>£101.75</b>   |

**Circular Chuck**

Used for holding work during turning operations on lathes and for grinding on internal, cylindrical or rotary grinding machines. Rigid assembly with thick top plate and operated by a removable handle. Magnetic adhesion: 61N/cm<sup>2</sup>.

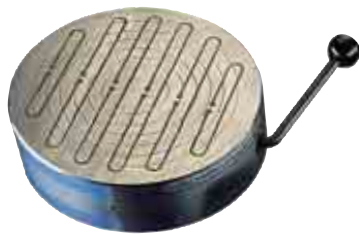

| Product Number | Diameter (mm) | Height (mm) | Weight each | Order Code <b>ECL-400</b> | List Price/1 | Offer Price/1  |
|----------------|---------------|-------------|-------------|---------------------------|--------------|----------------|
| AX 475C        | 121(4 3/4")   | 45(1 7/8")  | 3.60kg      | <b>-7080T</b>             | £410.18      | <b>£389.67</b> |

**Circular Magnetic Chucks**

Circular chucks are primarily designed to hold work during turning operations on lathes and for grinding on internal, cylindrical or rotary grinders. They are capable of gripping both heavy and light workpieces. A removable handle is used to energise the chuck which can also be partially energised to simplify the correct positioning of the workpiece. The top plate can be machined within limits to any required shape.



**Circular Magnetic Chucks - Standard Pole**

Pole spacing = 4.0mm steel/2mm brass. Force = 80N/cm<sup>2</sup>.

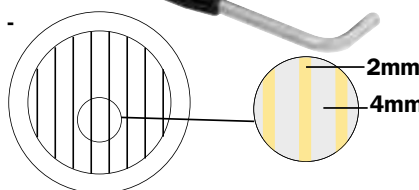

**Standard Pole**

| Product Number | Dia (mm) | Height (mm) | Weight (kgs) | Order Code <b>ECL-400</b> | List Price/1 | Offer Price/1  |
|----------------|----------|-------------|--------------|---------------------------|--------------|----------------|
| ECSP100        | 100      | 50          | 3.0          | <b>-1110A</b>             | £205.61      | <b>£195.33</b> |
| ECSP125        | 125      | 50          | 5.0          | <b>-1120B</b>             | £284.35      | <b>£270.13</b> |
| ECSP160        | 160      | 50          | 7.5          | <b>-1130C</b>             | £395.17      | <b>£375.41</b> |
| ECSP195        | 195      | 50          | 11.0         | <b>-1140D</b>             | £559.95      | <b>£531.95</b> |
| ECSP255        | 255      | 50          | 16.0         | <b>-1150E</b>             | £874.92      | <b>£831.17</b> |

**Circular Magnetic Chucks - Fine Pole**

Ideal for small or thin workpieces. Pole spacing = 1.5mm steel/0.5mm brass. Force = 80N/cm<sup>2</sup>.

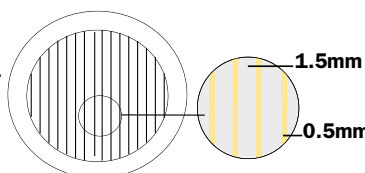

**Fine Pole**

| Product Number | Dia (mm) | Height (mm) | Weight (kgs) | Order Code <b>ECL-400</b> | List Price/1 | Offer Price/1  |
|----------------|----------|-------------|--------------|---------------------------|--------------|----------------|
| ECFP100        | 100      | 50          | 3.0          | <b>-1010A</b>             | £215.81      | <b>£205.02</b> |
| ECFP125        | 125      | 50          | 5.0          | <b>-1020B</b>             | £297.47      | <b>£282.60</b> |
| ECFP160        | 160      | 50          | 7.5          | <b>-1030C</b>             | £417.05      | <b>£396.20</b> |
| ECFP195        | 195      | 50          | 11.0         | <b>-1040D</b>             | £589.12      | <b>£559.66</b> |
| ECFP255        | 255      | 50          | 16.0         | <b>-1050E</b>             | £925.96      | <b>£879.66</b> |

**ECLIPSE** *Magnetic Sine Tables - Short Lift*  
MAGNETICS

Accuracy of sine table: within ±5 secs of an arc. Pole spacing: 2mm (1.5mm steel 0.5mm brass). Clamping force: 80 N/cm<sup>2</sup>. Sine table calculations included. Supplied with adjustment wrenches.



| Height at Zero    | Plate-mm | Base-mm |     |
|-------------------|----------|---------|-----|
|                   |          | L       | W   |
| <b>SSTFP1018:</b> | 73mm     | 175     | 100 |
| <b>SSTFP1325:</b> | 78mm     | 255     | 130 |
| <b>SSTFP1535:</b> | 89mm     | 350     | 150 |

| Product Number | Weight each | Order Code <b>ECL-400</b> | List Price/1 | Offer Price/1   |
|----------------|-------------|---------------------------|--------------|-----------------|
| SSTFP1018      | 10.0kg      | <b>-9004D</b>             | £1100.00     | <b>£1045.00</b> |
| SSTFP1325      | 20.5kg      | <b>-9006F</b>             | £1200.00     | <b>£1140.00</b> |
| SSTFP1535      | 36.0kg      | <b>-9008H</b>             | £1300.00     | <b>£1235.00</b> |

**Standard Range Magnetic Chucks**

Standard range chucks are designed to give high performance combined with competitive pricing. Using high energy rare earth neodymium magnets they give an evenly distributed clamping force. Trouble-free operation is assured with a rugged but accurate build. Each standard magnetic chuck features: brass and steel top plates, removable hexagon key handles that ensure ease of operation through a 180° arc (replacement handles are available on request). All chucks are supplied with side and end stops. All chucks are supplied with clamps and a one year warranty on parts and labour.



**Rectangular Magnetic Chucks - Standard Pole**

Pole spacing = 4.0mm steel/2mm brass. Force = 80N/cm<sup>2</sup>.

These chucks are primarily designed for grinding operations. They will effectively clamp all workpiece thicknesses down to 3mm.



**Standard Pole, Rectangular**

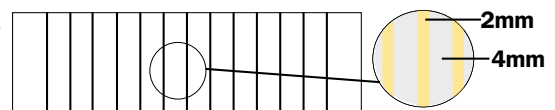

**Standard Pole**

| Product Number | Width (mm) | Length (mm) | Height (mm) | Weight (kgs) | Order Code <b>ECL-400</b> | List Price/1 | Offer Price/1  |
|----------------|------------|-------------|-------------|--------------|---------------------------|--------------|----------------|
| ERSP1018       | 100        | 180         | 50          | 8.0          | <b>-3610A</b>             | £205.36      | <b>£195.09</b> |
| ERSP1325       | 130        | 250         | 50          | 14.0         | <b>-3620B</b>             | £306.22      | <b>£290.91</b> |
| ERSP1530       | 150        | 300         | 50          | 18.5         | <b>-3630C</b>             | £415.59      | <b>£394.81</b> |
| ERSP1535       | 150        | 350         | 50          | 21.5         | <b>-3640D</b>             | £498.22      | <b>£473.31</b> |
| ERSP1545       | 150        | 450         | 50          | 27.5         | <b>-3650E</b>             | £640.40      | <b>£608.38</b> |
| ERSP2060       | 200        | 600         | 50          | 50.0         | <b>-3660F</b>             | £825.10      | <b>£783.85</b> |

**Rectangular Magnetic Chucks - Fine Pole**

Ideal for thin - medium grinding operations. Pole spacing = 1.5mm steel/0.5mm brass. Force = 80N/cm<sup>2</sup>.

They will usually clamp all workpiece thicknesses less than 3mm.

**Fine Pole, Rectangular**

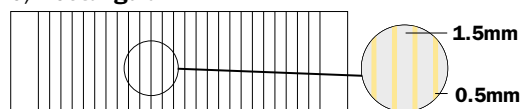

**Fine Pole**

| Product Number | Width (mm) | Length (mm) | Height (mm) | Weight (kgs) | Order Code <b>ECL-400</b> | List Price/1 | Offer Price/1  |
|----------------|------------|-------------|-------------|--------------|---------------------------|--------------|----------------|
| ERFP1018       | 100        | 180         | 50          | 8.0          | <b>-3510A</b>             | £217.52      | <b>£206.64</b> |
| ERFP1325       | 130        | 250         | 50          | 14.0         | <b>-3520B</b>             | £323.24      | <b>£307.08</b> |
| ERFP1530       | 150        | 300         | 50          | 18.5         | <b>-3530C</b>             | £442.32      | <b>£420.20</b> |
| ERFP1535       | 150        | 350         | 50          | 21.5         | <b>-3540D</b>             | £522.52      | <b>£496.39</b> |
| ERFP1545       | 150        | 450         | 50          | 27.5         | <b>-3550E</b>             | £676.85      | <b>£643.01</b> |
| ERFP2060       | 200        | 600         | 50          | 50.0         | <b>-3560F</b>             | £868.85      | <b>£825.41</b> |

Workshop Equipment



**Magnetic Grids - Square**

Magnetic grids are constructed from a number of highly polished magnetic rods, which are held in position at pre-determined centres. The powerful magnetic flux fields between the rods and these reach into the product stream, attracting and securing ferrous contamination as it flows through. Once attracted, the contamination sticks to the surface of the rod and eventually seeks sanctuary on the underside of the rod where it is safe from wash off effects of continuous flow. Manufactured using 316 stainless steel. Two-sided frame design. Highly polished. Magnetic performance on rod surface: 9,000 Gauss. Supplied fully tested and certified. Special sizes available by request.



For further technical information please ask for datasheet 521.

| Part Number             | Size (mm) | No. of Rods | Weight (kg) | Order Code ECL-400 | Offer Price/1  |
|-------------------------|-----------|-------------|-------------|--------------------|----------------|
| <b>Rod Centres 60mm</b> |           |             |             |                    |                |
| GM1515/HS               | 150 x 150 | 2           | 2.0         | <b>-8410A</b>      | <b>£199.44</b> |
| GM2020/HS               | 200 x 200 | 3           | 3.4         | <b>-8412C</b>      | <b>£409.45</b> |
| <b>Rod Centres 55mm</b> |           |             |             |                    |                |
| GM2525/HS               | 250 x 250 | 4           | 5.2         | <b>-8414E</b>      | <b>£448.55</b> |
| GM3030/HS               | 300 x 300 | 5           | 7.4         | <b>-8416G</b>      | <b>£612.93</b> |
| GM3535/HS               | 350 x 350 | 6           | 10.0        | <b>-8418J</b>      | <b>£839.04</b> |

**Magnetic Rods**

High intensity rare earth separator rods are extremely efficient for removing fine ferrous contamination from free flowing products such as sugar, grain, tea and liquids. These rods are ideal for engineers wishing to design their own magnetic separators. 1" diameter. Magnetic performance on rod surface: 9,000 Gauss. Supplied with M6 drilled and tapped hole on one end. Highly polished. Manufactured using 316 stainless steel. Supplied fully tested and certified. Rods are available up to 1000mm in length please contact our sales team for more details.

For further technical information please ask for datasheet 518.

| Part Number | Overall Lgth (mm) | Order Code ECL-400 | List Price/1 | Offer Price/1  |
|-------------|-------------------|--------------------|--------------|----------------|
| SR100       | 100               | <b>-8910A</b>      | £82.81       | <b>£78.67</b>  |
| SR150       | 150               | <b>-8912C</b>      | £92.49       | <b>£87.87</b>  |
| SR190       | 200               | <b>-8914E</b>      | £102.20      | <b>£97.09</b>  |
| SR250       | 250               | <b>-8916G</b>      | £115.49      | <b>£109.72</b> |
| SR300       | 300               | <b>-8918J</b>      | £125.20      | <b>£118.94</b> |
| SR350       | 350               | <b>-8920L</b>      | £134.88      | <b>£128.14</b> |
| SR400       | 400               | <b>-8922N</b>      | £144.59      | <b>£137.36</b> |
| SR450       | 450               | <b>-8924Q</b>      | £154.30      | <b>£146.59</b> |
| SR500       | 500               | <b>-8926S</b>      | £167.59      | <b>£159.21</b> |



**Magnetic Sampling Probe**

High intensity magnetic sampling probes are ideal for quality control personnel to quickly and easily carry out product purity inspections on any power granulate or liquid for ferrous contamination. Manufactured using 316 stainless steel. Incorporating quick release mechanism. 76mm diameter hand guard. Highly polished. Magnetic performance on rod surface 9,000 Gauss.



For further technical information please ask for datasheet 515.

| Part Number | Magnetic Length (mm) | Order Code ECL-400 | List Price/1 | Offer Price/1  |
|-------------|----------------------|--------------------|--------------|----------------|
| MSP100      | 100                  | <b>-8610A</b>      | £102.99      | <b>£97.84</b>  |
| MSP300      | 300                  | <b>-8614E</b>      | £169.26      | <b>£160.80</b> |

**Magnetic Strips**

These units are extremely versatile and can be placed above conveyors, at the side of chute work or even placed on finish product outlet points. High intensity rare earth neodymium magnets are fully encased within a stainless steel shroud allowing the unit to be utilised in wet applications. Deep fields of magnetic energy are emitted from the front face attracting ferrous contamination as it passes the magnetic face. Manufactured using 304 stainless steel. Units supplied brushed finish. Complete with threaded holes to rear face for mounting. Customer to specify mounting positions.

Magnetic performance on strip surface: 5,000 Gauss.

For further technical information please ask for datasheet 508.

50mm Deep

| Part Number | Size (mm) (L x W) | Weight (kg) | Order Code ECL-400 | Offer Price/1  |
|-------------|-------------------|-------------|--------------------|----------------|
| SMN100      | 100x100           | 2.5         | <b>-8810A</b>      | <b>£175.03</b> |
| SMN200      | 200x100           | 5.0         | <b>-8812C</b>      | <b>£229.15</b> |
| SMN300      | 300x100           | 7.5         | <b>-8814E</b>      | <b>£289.03</b> |
| SMN400      | 400x100           | 10.0        | <b>-8816G</b>      | <b>£343.15</b> |
| SMN500      | 500x100           | 12.5        | <b>-8818J</b>      | <b>£403.03</b> |



Micromag is the latest generation of magnetic filter, which is capable of sub-micron filtration levels with minimal pressure drop, fluid loss, environmental impact and running costs.

**Why Install a Micromag Filter?**

Ferrous and paramagnetic contamination is the most damaging of all the foreign matter that is found in any fluid. It is this contamination that causes wear in pumps, gears, slideways and valves. It also increases fluid degradation, which stops the fluid from performing its function, with possible catastrophic results.

**Filtration Capacity**

Micromag may be compact in size but does have a holding capacity no other filter can match. Unit holding capabilities are 5" (900g), 10" (1800g) and 20" (3800g) of contamination resulting in less downtime and increased production! The clear filter housing gives the operator a visual indication when the unit requires cleaning. Cleaning is very simple and is conducted using the supplied cleaning tool. The units can be fully cleaned and back on line within one minute.



**MM Filters**

| Type | Size | Capacity | Order Code ECL-400 | List Price/1 | Offer Price/1  |
|------|------|----------|--------------------|--------------|----------------|
| MM5  | 5"   | 900g     | <b>-8501A</b>      | £317.13      | <b>£301.27</b> |
| MM10 | 10"  | 1800g    | <b>-8510G</b>      | £532.13      | <b>£505.52</b> |
| MM20 | 20"  | 3800g    | <b>-8520A</b>      | £811.63      | <b>£771.05</b> |

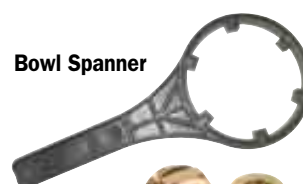

Bowl Spanner



Port Adaptors

Lid Mounting Bracket



Core Cleaning Post

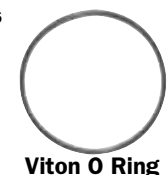

Viton O Ring

**Ancillary Equipment to suit MM5 Filters**

| Description  | Order Code ECL-400 | List Price/1 | Offer Price/1 |
|--------------|--------------------|--------------|---------------|
| Bowl Spanner | <b>-8502B</b>      | £9.00        | <b>£8.55</b>  |

**Ancillary Equipment to suit MM10 Filters**

| Description             | Order Code ECL-400 | List Price/1 | Offer Price/1 |
|-------------------------|--------------------|--------------|---------------|
| Bowl Spanner            | <b>-8511H</b>      | £9.00        | <b>£8.55</b>  |
| Core Cleaning Post      | <b>-8512J</b>      | £15.00       | <b>£14.25</b> |
| Lid Mounting Bracket    | <b>-8513K</b>      | £11.00       | <b>£10.45</b> |
| Port Adaptors 1" - 3/4" | <b>-8514L</b>      | £17.00       | <b>£16.15</b> |
| Viton Seal Kit          | <b>-8515M</b>      | £10.00       | <b>£9.50</b>  |

**Ancillary Equipment to suit MM20 Filters**

| Description        | Order Code ECL-400 | List Price/1 | Offer Price/1 |
|--------------------|--------------------|--------------|---------------|
| Bowl Spanner       | <b>-8521B</b>      | £9.00        | <b>£8.55</b>  |
| Core Cleaning Post | <b>-8522C</b>      | £15.00       | <b>£14.25</b> |

**GROUP 404 BIN STORAGE SYSTEMS**

**MATLOCK** Plastic Storage Bins

Manufactured from high strength polypropylene. Fit on standard louvre panel, interlocking design. Supplied with risers and label holders

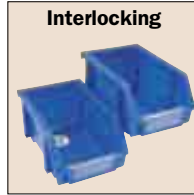
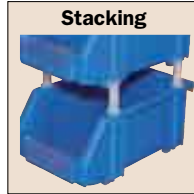

**Storage Bin Accessories**

For Matlock storage bins.

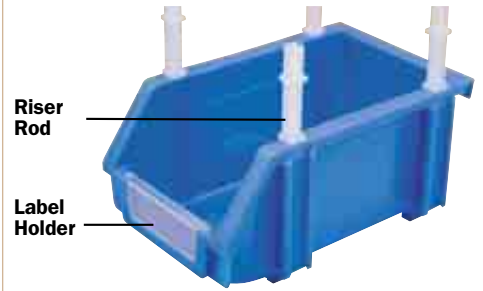

| Description                            | Order Code MTL-404 | Offer Price/1 |
|--|--------------------|---------------|
| Set of 4 Riser Rods                    | -9010K             | £1.12         |
| Single Riser rod for No.3A, 4 & 5 Bins | -9020K             | £1.12         |
| Label Holder For No.0 Bins             | -3500K             | £0.90         |
| Label Holder For No.1 Bins             | -3510K             | £0.90         |
| Label Holder For No.2 Bins             | -3520K             | £0.99         |
| Label Holder For No.3 & 4 Bins         | -3530K             | £1.12         |
| Label Holder For No.3A & 5 Bins        | -3540K             | £1.12         |

**'Anti-Bump' Locking Clips**

Made from zinc plated spring steel. Designed for use with Matlock louvre panels and bins. Effectively locks the bin into place on the panel to avoid accidental 'knock-off'. Also ideal for use on panels fitted to vans to avoid bins coming dislodged due to the effects of cornering and bumpy ground/road surfaces.



| Description              | Pack Qty | Order Code MTL-404 | Offer Price/Pk |
|--------------------------|----------|--------------------|----------------|
| 'Anti-Bump' Locking Clip | 10       | -9100K             | £3.35          |

| Size  | Dimensions L x W x H (mm) | Order Code MTL-404 Colours |        |        |        | Box Quantity | Offer Price/1 |
|-------|---------------------------|----------------------------|--------|--------|--------|--------------|---------------|
|       |                           | Blue                       | Green  | Red    | Yellow |              |               |
| No.0  | 130 x 85 x 53             | -1000B                     | -1000G | -1000R | -1000Y | 300          | £0.65         |
| No.1  | 163 x 104 x 80            | -1010B                     | -1010G | -1010R | -1010Y | 100          | £1.23         |
| No.2  | 237 x 157 x 132           | -1020B                     | -1020G | -1020R | -1020Y | 64           | £2.29         |
| No.3  | 278 x 222 x 165           | -1030B                     | -1030G | -1030R | -1030Y | 24           | £5.17         |
| No.3A | 350 x 280 x 184           | -1035B                     | -1035G | -1035R | -1035Y | 8            | £6.39         |
| No.4  | 425 x 280 x 184           | -1040B                     | -1040G | -1040R | -1040Y | 12           | £8.79         |
| No.5  | 425 x 280 x 260           | -1050B                     | -1050G | -1050R | -1050Y | 8            | £10.36        |

**Mobile Trolleys/Racks**

Similar to a free standing rack by mobile. Fitted with four 5" castors to the base which supports double sided Louvre Panels. Available in one height and two widths.

**Colour:** Dark grey/light grey.

**NEW**



**Storage Bins Not Included**

| Description        | Size (H x W) | Order Code MTL-405 | Offer Price/Pk |
|--------------------|--------------|--------------------|----------------|
| Mobile Louvre Rack | 1080x457     | -7410K             | £143.99        |
|                    | 1080x877     | -7420K             | £189.59        |

**Bench Assembly Units**

A free standing unit supporting a louvre Panel for use on benches or tables. Available in one height and two widths. Kit comprises: Louvre Panel, support rods and fixings.

**Colour:** Light grey.

**NEW**



**Storage Bins Not Included**

| Description       | Size (H x W) | Order Code MTL-405 | Offer Price/Pk |
|-------------------|--------------|--------------------|----------------|
| Bench Louvre Rack | 457x436      | -7250K             | £15.19         |
|                   | 457x852      | -7260K             | £23.99         |

**Free Standing Racks**

Available in two heights and two widths. Made from 16swg channel section which supports Louvre Panels either single or double sided.

**Colour:** Dark grey/light grey.

**NEW**



**Storage Bins Not Included**

| Description                   | Size (H x W) | Order Code MTL-405 | Offer Price/Pk |
|-------------------------------|--------------|--------------------|----------------|
| D/S Free Standing Louvre Rack | 924x457      | -7610K             | £99.96         |
|                               | 924x871      | -7615K             | £143.99        |
|                               | 1838x457     | -7620K             | £146.36        |
| S/S Free Standing Louvre Rack | 1838x871     | -7625K             | £223.99        |
|                               | 924x457      | -7650K             | £71.19         |
|                               | 924x871      | -7655K             | £159.99        |
|                               | 1838x457     | -7660K             | £98.36         |
|                               | 1838x871     | -7665K             | £149.59        |



**Spigots for Louvre Panels**

For use with louvered panels. Designed to carry awkwardly shaped items. All with corrosion resistant zinc finish. 16swg construction.

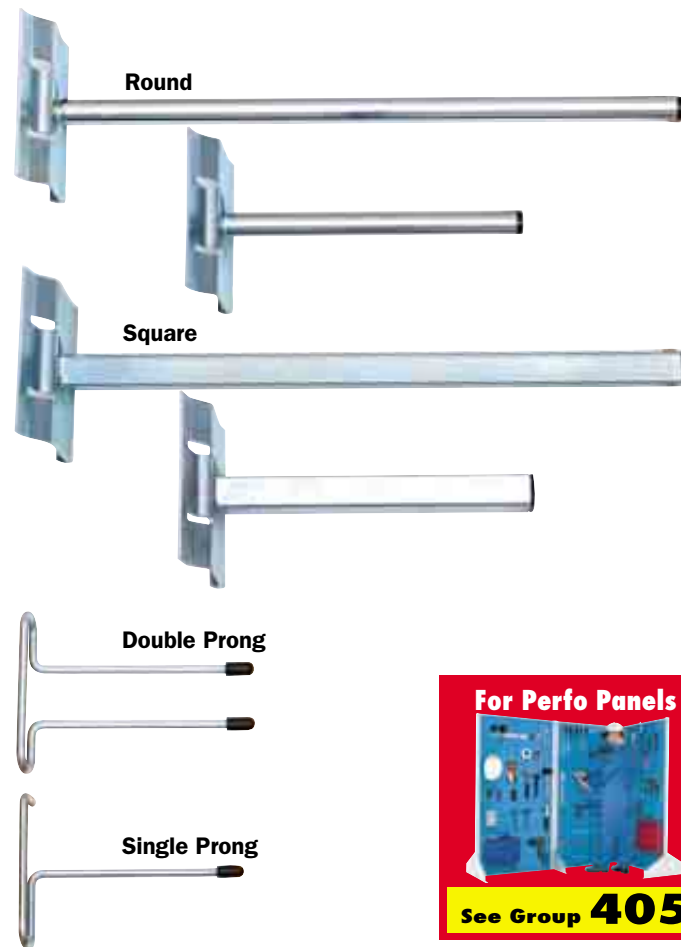

**For Perfo Panels**

**See Group 405**

| Type         | Dimensions (mm)     | Order Code MTL-404 | Offer Price/1 |
|--------------|---------------------|--------------------|---------------|
| Single Prong | 5.0mm dia. x 100mm  | -3600K             | £1.66         |
| Double Prong | 5.0mm dia. x 100mm  | -3610K             | £2.15         |
| Square       | 16.0mm sq x 150mm   | -3620K             | £4.51         |
| Square       | 16.0mm sq x 300mm   | -3630K             | £5.27         |
| Round        | 12.7mm dia. x 150mm | -3640K             | £4.45         |
| Round        | 12.7mm dia. x 300mm | -3650K             | £7.87         |

**MATLOCK Steel Louvred Panels**

Pressed steel panels with high frequency louvres that will accept most makes of plastic storage bin. High frequency louvres allow bins to be hung in a high-density configuration in any mix of sizes/colours. The lip on the rear of the plastic storage bin sits securely over the louvre of the panel. The modular design allows storage bins to be easily removed and replaced when required.

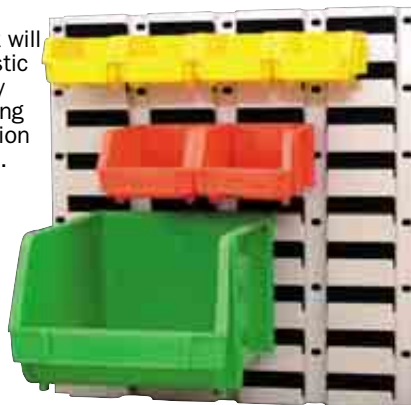

**Bins supplied separately - See Previous page**

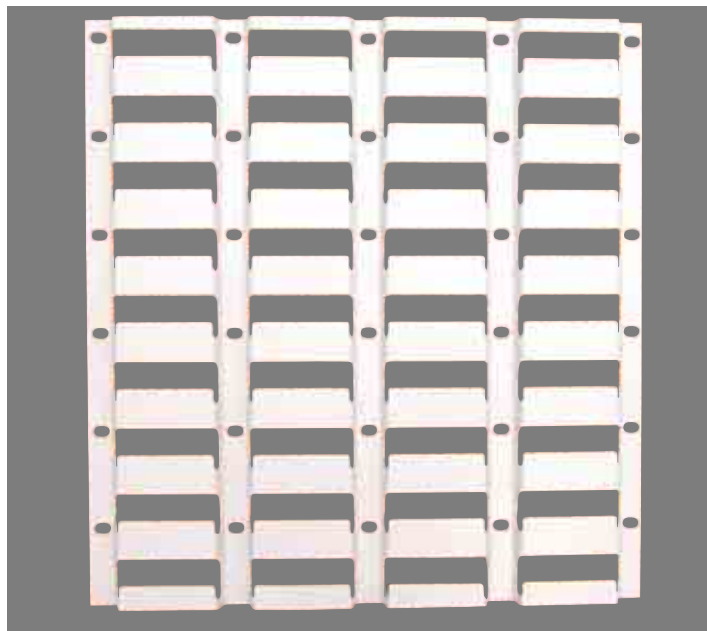

| Type   | Width x Height (mm) | Order Code MTL-404 | Offer Price/1 |
|--------|---------------------|--------------------|---------------|
| LP450  | 450 x 450           | -2004P             | £11.29        |
| LP900  | 450 x 900           | -2009P             | £19.77        |
| LP1600 | 450 x 1600          | -2016P             | £36.91        |
| LP1800 | 450 x 1800          | -2018P             | £42.43        |

**Cardboard Storage Bins**

For easy identification and storage of parts and other components on shelves. Manufactured from corrugated card with writable panels. Supplied flat in packs of 50.



| Size L x W x H (mm)               | Pack Qty | Order Code CTL-804 | List Price/Pk | Offer Price/Pk |
|-----------------------------------|----------|--------------------|---------------|----------------|
| 152 x 76 x 115 ( 6" x 3" x 4.5")  | 50       | -2710K             | £26.65        | £15.99         |
| 228 x 100 x 115 ( 9" x 4" x 4.5") | 50       | -2715K             | £39.37        | £23.62         |
| 228 x 152 x 115 ( 9" x 6" x 4.5") | 50       | -2720K             | £41.89        | £25.13         |
| 228 x 204 x 115 ( 9" x 8" x 4.5") | 50       | -2725K             | £43.89        | £26.33         |
| 304 x 100 x 115 (12" x 4" x 4.5") | 50       | -2730K             | £42.53        | £25.52         |

**Parts, Component & Tool Storage Bins**

High strength polypropylene Euro boxes with reinforced corners and rims and integral interlocking hinged lids. Smooth flat base allows silent movement on conveyors making them suitable for use in distribution centres or warehouse storage. All containers feature ergonomic hand and can be sealed using security tags.

**Available in 20, 40 or 54ltr capacities.**



| Capacity | Size (L x W x H) (mm) | Colour | Order Code MTL-404 | Offer Price/1 |
|----------|-----------------------|--------|--------------------|---------------|
| 20ltr    | 400 x 300 x 260       | Blue   | -2500K             | £10.88        |
| 40ltr    | 600 x 400 x 250       |        | -2520K             | £17.73        |
| 54ltr    | 600 x 400 x 335       |        | -2530K             | £18.85        |
| 20ltr    | 400 x 300 x 260       | Grey   | -2600K             | £9.89         |
| 40ltr    | 600 x 400 x 250       |        | -2620K             | £16.12        |
| 54ltr    | 600 x 400 x 335       |        | -2630K             | £17.14        |

**CONTRACT PRICES AVAILABLE FOR VOLUME PURCHASES**

Tough welded steel cupboards complete with galvanised shelves and bins in the colours shown. The bins are manufactured from high density polythylene and are resistant to most acids, alkalis, greases and oils and are suitable for use in temperature ranges from -35° to +80°. All bins are supplied with a label and integral holder.



**-3365W**



**-3361V**

**Bin Sizes**

| Product Number | Dimensions W x D x H | Bins | Shelves | Sizes     | Order Code    | List Price/1 | Offer Price/1  | Bin Sizes |                 |                   |
|----------------|----------------------|------|---------|-----------|---------------|--------------|----------------|-----------|-----------------|-------------------|
|                |                      |      |         |           |               |              |                | Size      | Dimensions (mm) | Capacity (Litres) |
| 169 16 000.11V | 750 x 350 x 1000mm   | 20   | 4       | 20 x No 3 | <b>-3365W</b> | £300.30      | <b>£282.28</b> | 1         | 103 x 85 x 53   | 0.4               |
| 169 16 001.11V | 1000 x 350 x 1000mm  | 30   | 4       | 30 x No 3 | <b>-3361S</b> | £400.26      | <b>£376.24</b> | 1B        | 103 x 121 x 53  | 0.5               |
| 169 16 002.11V | 750 x 550 x 1000mm   | 8    | 3       | 8 x No 5  | <b>-3361T</b> | £348.95      | <b>£328.01</b> | 2         | 103 x 165 x 83  | 1.0               |
| 169 16 003.11V | 1000 x 550 x 1000mm  | 12   | 3       | 12 x No 5 | <b>-3361V</b> | £460.03      | <b>£432.43</b> | 3         | 148 x 241 x 128 | 3.5               |
|                |                      |      |         |           |               |              |                | 4         | 209 x 356 x 164 | 10.0              |
|                |                      |      |         |           |               |              |                | 5         | 310 x 500 x 190 | 30.0              |

**Bin Cupboards**

Industrial bin cupboards with heavy duty housing and three point locking system. The bins have been selected to fully utilise the storage space available.



**-3361W**



**-3361Z**

**Bin Sizes**

| Product Number | Dimensions W x D x H | Bins | Shelves | Sizes     | Order Code    | List Price/1 | Offer Price/1  | Bin Sizes |                 |                   |
|----------------|----------------------|------|---------|-----------|---------------|--------------|----------------|-----------|-----------------|-------------------|
|                |                      |      |         |           |               |              |                | Size      | Dimensions (mm) | Capacity (Litres) |
| 169 16 004.11V | 750 x 350 x 2000mm   | 44   | 10      | 44 x No 3 | <b>-3361W</b> | £528.42      | <b>£496.71</b> | 1         | 103 x 85 x 53   | 0.4               |
| 169 16 005.11V | 1000 x 350 x 2000mm  | 66   | 10      | 66 x No 3 | <b>-3361X</b> | £682.12      | <b>£641.19</b> | 1B        | 103 x 121 x 53  | 0.5               |
| 169 16 006.11V | 750 x 550 x 2000mm   | 14   | 6       | 14 x No 5 | <b>-3361Y</b> | £555.07      | <b>£521.77</b> | 2         | 103 x 165 x 83  | 1.0               |
| 169 16 007.11V | 1000 x 550 x 2000mm  | 21   | 6       | 21 x No 5 | <b>-3361Z</b> | £712.91      | <b>£670.14</b> | 3         | 148 x 241 x 128 | 3.5               |
|                |                      |      |         |           |               |              |                | 4         | 209 x 356 x 164 | 10.0              |
|                |                      |      |         |           |               |              |                | 5         | 310 x 500 x 190 | 30.0              |

**bott Panel Trolleys**

These trolleys allow easy transportation around the workplace. The panels may be fitted upright or on a slight incline, the lower level may be omitted, to provide a useful storage space for toolcases or boxed items. **Dimensions (W x D x H):** 1000 x 650 x 1200 or 1600mm.



**-2360M**



**-2000A**

**Bin Sizes**

| Size | Dimensions (mm) | Capacity (Litres) |
|------|-----------------|-------------------|
| 1    | 103 x 85 x 53   | 0.4               |
| 1B   | 103 x 121 x 53  | 0.5               |
| 2    | 103 x 165 x 83  | 1.0               |
| 3    | 148 x 241 x 128 | 3.5               |
| 4    | 209 x 356 x 164 | 10.0              |
| 5    | 310 x 500 x 190 | 30.0              |

| Product Number | Panels   | Height | Accessories       | Weight | Order Code    | List Price/1 | Offer Price/1  |
|----------------|----------|--------|-------------------|--------|---------------|--------------|----------------|
| 140 260 38.11  | 4 Louvre | 1200   | Empty             | 30kg   | <b>-2363Q</b> | £378.23      | <b>£355.54</b> |
| 130 311 81.11  | 4 Louvre | 1200   | 108 Piece Bin Kit | 65kg   | <b>-2000A</b> | £535.19      | <b>£503.08</b> |
| 140 260 28.03  | 6 Louvre | 1600   | Empty             | 32kg   | <b>-2362P</b> | £467.61      | <b>£439.55</b> |
| 140 260 17.11  | 6 Louvre | 1600   | 108 Piece Bin Kit | 70kg   | <b>-2360M</b> | £714.82      | <b>£671.93</b> |

**Louvred Cupboards**

These heavy duty cupboards provide a strong and secure component store. The back panel and inner doors are louvred to accept plastic bins. The cupboard is offered empty or as standard kits complete with bins as shown.

**Dimensions (W x D x H):** 1000 x 600 x 2000mm.



**-4125L**



**-4126M**

| Product Number | Bins | Sizes                                      | Order Code    | List Price/1 | Offer Price/1  |
|----------------|------|--|---------------|--------------|----------------|
| 400 211 28.11V | --   | Empty                                      | <b>-4124K</b> | £643.00      | <b>£604.42</b> |
| 400 211 29.11V | 154  | 8 x No 1, 114 x No 2, 20 x No 3, 12 x No 4 | <b>-4125L</b> | £922.00      | <b>£866.68</b> |
| 400 211 30.11V | 81   | 54 x No 2, 5 x No 3, 16 x No 4, 6 x No 5   | <b>-4126M</b> | £925.00      | <b>£869.50</b> |

**CONTRACT PRICES AVAILABLE FOR VOLUME PURCHASES**

All Prices Exclude V.A.T. © 2011

Workshop Equipment

**bott** Workshop Tool Cabinets

Single width cupboards. Strong and versatile economy storage within the workshop. Fully welded construction with reinforced doors. Compact size of 500mm x 550mm x 1000mm for a variety of uses. 75mm high simple steel drawer unit with integral handle. Espagnolette 2 point locking with flush fitting handle. Adjustable shelves on 100mm pitch. Finished in epoxy powder coat - grey/blue.



-3045V



-3049Z



-3044T



| Product Number | Dimensions H x W x D (mm) | No. of Shelves | No. of Drawers | Order Code <b>BOT-405</b> | List Price/1 | Offer Price/1  |
|----------------|---------------------------|----------------|----------------|---------------------------|--------------|----------------|
| 169.12.008     | 1000 x 500 x 550          | 1              | -              | -3044T                    | £166.43      | <b>£156.44</b> |
| 169.12.009     | 1000 x 500 x 550          | 1              | 1              | -3045V                    | £188.74      | <b>£177.42</b> |
| 169.12.021     | 1000 x 500 x 550          | 2              | -              | -3049Z                    | £176.93      | <b>£166.31</b> |

**Double Width Cupboards**

With the same features as the single width models, but with extra storage capacity.



-3046W



-3047X



-3048Y



| Product Number | Dimensions H x W x D (mm) | No. of Shelves | No. of Drawers | Order Code <b>BOT-405</b> | List Price/1 | Offer Price/1  |
|----------------|---------------------------|----------------|----------------|---------------------------|--------------|----------------|
| 169.12.016     | 1000 x 1000 x 550         | 2              | -              | -3046W                    | £269.85      | <b>£253.66</b> |
| 169.12.017     | 1000 x 1000 x 550         | 2              | 2              | -3047X                    | £314.48      | <b>£295.61</b> |
| 169.12.019     | 1000 x 1000 x 550         | 1              | 2              | -3048Y                    | £296.36      | <b>£278.58</b> |

Workshop Equipment

**Wall Mounted Tool Cabinets**

Optimise your storage area by using the walls. Pre-punched for wall fixing, ideal for positions above benching or machinery. Fully welded construction. Available in two sizes. 75mm high simple steel drawer units with integral handle. Espagnolette two point locking with flush fitting handle. Adjustable shelves. Finished in epoxy powder coat - grey/blue.



-3040P



-3041Q

| Product Number | Dimensions H x W x D (mm) | No. of Shelves | No. of Drawers | Order Code <b>BOT-405</b> | List Price/1 | Offer Price/1  |
|----------------|---------------------------|----------------|----------------|---------------------------|--------------|----------------|
| 169.12.000     | 600 x 500 x 350           | 1              | -              | -3040P                    | £96.86       | <b>£91.05</b>  |
| 169.12.001     | 600 x 500 x 350           | 2              | 1              | -3041Q                    | £123.90      | <b>£116.47</b> |
| 169.12.002     | 600 x 750 x 350           | 1              | -              | -3042R                    | £129.41      | <b>£121.65</b> |
| 169.12.003     | 600 x 750 x 350           | 2              | 1              | -3043S                    | £164.06      | <b>£154.22</b> |



-3042R



-3043S

**bott** Storage Cupboards

General storage cupboards with 50kg UDL capacity per shelf. All shelves adjustable on 25mm pitch. 1m or 2m high, 350 or 550mm deep, 750 or 1000mm wide, 2 point locking mechanism.

Shelf Capacity  
**50kg**  
Uniformly  
Distributed Load



-3000A



-3010D



-3020G



-3021H

Workshop Equipment

| Product Number | Dimensions W x D x H (mm) | No. of Shelves | Order Code BOT-405 | List Price/1 | Offer Price/1 | Product Number | Dimensions W x D x H (mm) | No. of Shelves | Order Code BOT-405 | List Price/1 | Offer Price/1 |
|----------------|---------------------------|----------------|--------------------|--------------|---------------|----------------|---------------------------|----------------|--------------------|--------------|---------------|
| 169.11.808     | 750 x 350 x 1000          | 2              | -3031M             | £233.63      | £219.61       | 169.11.476     | 750 x 550 x 1000          | 2              | -3000A             | £247.80      | £232.93       |
| 169.11.812     | 1000 x 350 x 1000         | 2              | -3032N             | £285.08      | £267.98       | 169.11.534     | 1000 x 550 x 1000         | 2              | -3010D             | £308.70      | £290.18       |
| 169.11.600     | 750 x 350 x 2000          | 4              | -3022J             | £329.70      | £309.92       | 169.11.601     | 750 x 550 x 2000          | 4              | -3020G             | £373.28      | £350.88       |
| 169.11.602     | 1000 x 350 x 2000         | 4              | -3023K             | £394.28      | £370.62       | 169.11.604     | 1000 x 550 x 2000         | 4              | -3021H             | £441.00      | £414.54       |

**CONTRACT PRICES AVAILABLE FOR VOLUME PURCHASES**

All Prices Exclude V.A.T. © 2011

GROUP  
**405 CUPBOARDS & LOCKERS**

**bott Kitted Cupboards**

**NEW**

All models 1000mm wide x 550 deep  
Tough, welded construction  
Lockable, reinforced doors  
Galvanised steel shelves and roller bearing drawers all with 50kg UDL capacity  
Mpx wooden worktops for enclosed mini-workshops  
Internal panels in perfo and louvre styles  
Optional hook, bin and divider kits  
RAL5010 blue/RAL7035 grey powdercoat finish

Cupboard shown with optional 15 piece hook kit (BOT-405-2381B) and 32 piece bin kit. Tools not included.

**Drawers:** 2x 75mm, 3x 125mm, 2x 175mm.

**Panels:** 1x louvre, 1x perfo.

**Worktops:** 1.

**Drawers:** 1x 75mm, 1x 125mm, 1x 175mm.  
**Shelves:** 1.



| Product Number | Dimensions H x W x D (mm) | Order Code <b>BOT-405</b> | List Price/1 | <b>Offer Price/1</b> |
|----------------|---------------------------|---------------------------|--------------|----------------------|
| 169.161 05.11V | 1000 x 1000 x 550         | <b>-3366B</b>             | £456.23      | <b>£428.86</b>       |

**Drawers:** 2x 125mm.  
**Shelves:** 4.



| Product Number | Dimensions H x W x D (mm) | Order Code <b>BOT-405</b> | List Price/1 | <b>Offer Price/1</b> |
|----------------|---------------------------|---------------------------|--------------|----------------------|
| 169.161 14.11V | 2000 x 1000 x 550         | <b>-3366L</b>             | £558.08      | <b>£524.60</b>       |

**Drawers:** 1x 75mm, 2x 125mm, 1x 175mm.  
**Shelves:** 3.



| Product Number | Dimensions H x W x D (mm) | Order Code <b>BOT-405</b> | List Price/1 | <b>Offer Price/1</b> |
|----------------|---------------------------|---------------------------|--------------|----------------------|
| 169.161 16.11V | 2000 x 1000 x 550         | <b>-3366M</b>             | £647.06      | <b>£608.24</b>       |



| Product Number | Dimensions H x W x D (mm) | Order Code <b>BOT-405</b> | List Price/1 | <b>Offer Price/1</b> |
|----------------|---------------------------|---------------------------|--------------|----------------------|
| 169.161 13.11V | 2000 x 1000 x 550         | <b>-3366K</b>             | £865.99      | <b>£814.03</b>       |

Cupboard shown with optional 15 piece hook kit (BOT-405-2381B) and 32 piece bin kit. Tools not included.

**Drawers:** 1x 75mm, 1x 125mm, 1x 175mm.

**Panels:** 1x louvre, 1x perfo.

**Shelves:** 1.

**Worktops:** 1.



| Product Number | Dimensions H x W x D (mm) | Order Code <b>BOT-405</b> | List Price/1 | <b>Offer Price/1</b> |
|----------------|---------------------------|---------------------------|--------------|----------------------|
| 169.161 12.11V | 2000 x 1000 x 550         | <b>-3366J</b>             | £659.93      | <b>£620.33</b>       |

Workshop Equipment

**CUPBOARDS & LOCKERS**

**bott Kitted Cupboards**

**NEW**

Tough, welded construction with lockable, reinforced doors, galvanised steel shelves and roller bearing drawers all with 50kg UDL capacity. RAL5010 blue/RAL7035 grey powdercoat finish

**Drawers:** 1x 75mm, 1x 125mm.  
**Shelves:** 1.



**10 - 14 Days**

| Product Number | Dimensions H x W x D (mm) | Order Code <b>BOT-405</b> | List Price/1 | Offer Price/1  |
|----------------|---------------------------|---------------------------|--------------|----------------|
| 169.161 01.11V | 1000 x 750 x 550          | <b>-3365X</b>             | £327.86      | <b>£308.19</b> |

**Drawers:** 1x 75mm, 1x 125mm, 1x 175mm.  
**Shelves:** 4.



**10 - 14 Days**

| Product Number | Dimensions H x W x D (mm) | Order Code <b>BOT-405</b> | List Price/1 | Offer Price/1  |
|----------------|---------------------------|---------------------------|--------------|----------------|
| 169.161 07.11V | 2000 x 750 x 550          | <b>-3366D</b>             | £530.78      | <b>£498.93</b> |

**Drawers:** 2x 75mm, 4x 125mm, 2x 175mm.  
**Shelves:** 3.



**10 - 14 Days**

| Product Number | Dimensions H x W x D (mm) | Order Code <b>BOT-405</b> | List Price/1 | Offer Price/1  |
|----------------|---------------------------|---------------------------|--------------|----------------|
| 169.161 09.11V | 2000 x 750 x 550          | <b>-3366F</b>             | £774.11      | <b>£727.66</b> |

**Roller Shutter Door Cupboard**

Tough general purpose storage cupboard designed for storage in industrial environments. Supplied with 3 adjustable shelves each with 50kg UDL capacity.



**10 - 14 Days**

| Product Number | Dimensions H x W x D (mm) | Order Code <b>BOT-405</b> | List Price/1 | Offer Price/1  |
|----------------|---------------------------|---------------------------|--------------|----------------|
| 169.116 28.16V | 2000 x 1000 x 550         | <b>-3024N</b>             | £682.50      | <b>£641.55</b> |

**Extra Shelf**

| Product Number | Dimensions W x D (mm) | Order Code <b>BOT-405</b> | List Price/1 | Offer Price/1 |
|----------------|-----------------------|---------------------------|--------------|---------------|
| 169.229 02.51V | 1000 x 550            | <b>-3450E</b>             | £28.35       | <b>£26.65</b> |

**CONTRACT PRICES AVAILABLE FOR VOLUME PURCHASES**

All Prices Exclude V.A.T. © 2011

Workshop Equipment

**GROUP 405 CUPBOARDS & LOCKERS**

**Sliding Door Cupboards - With Shelves**

Space-efficient doors prevent obstruction of workspace. 100kgs UDL capacity per shelf. Shelves adjustable on a 25mm pitch. Fully lockable.

Shelf Capacity  
**100kg**  
Uniformly Distributed Load

**Window Door Cupboard - With Shelves**

Window doors allow immediate identification of cupboard contents. 100kgs UDL capacity per shelf. Shelves adjustable on a 25mm pitch. Fully lockable.

**Dimensions (W x D x H):**  
1050 x 650 x 2000mm.



**-4128P**



**-4129Q**



| Product Number | Dimensions W x D x H (mm) | No. of Shelves | Order Code BOT-405 | List Price/1 | Offer Price/1  |
|----------------|---------------------------|----------------|--------------------|--------------|----------------|
| 400.21.138.11V | 1050 x 650 x 1000         | 2              | <b>-4128P</b>      | £511.00      | <b>£480.34</b> |
| 400.21.141.11V | 1050 x 650 x 2000         | 4              | <b>-4129Q</b>      | £727.00      | <b>£683.38</b> |
| 400.22.062.11V | 1300 x 650 x 1000         | 2              | <b>-4152C</b>      | £560.00      | <b>£526.40</b> |
| 400.22.065.11V | 1300 x 650 x 2000         | 4              | <b>-4153D</b>      | £801.00      | <b>£752.94</b> |



| Product Number | No. of Shelves | Order Code BOT-405 | List Price/1 | Offer Price/1  |
|----------------|----------------|--------------------|--------------|----------------|
| 400.21.134.11V | 4              | <b>-4127N</b>      | £794.00      | <b>£746.36</b> |

**Roller Shutter Cupboards**

Where space is restricted, traditional cupboard doors can encroach into walkways or working areas. Our roller shutter cupboard provides the solution. Easy access in confined areas - the roller shutter neatly stores away in the upper section of the cupboard, rolling smoothly between open and closed positions.

All drawers are 175mm and have a 100kg capacity. Fully lockable. Smooth roller shutter. Mid level hand grip. Adjustable steel shelves. **Dimensions (W x D x H):** 1050 x 650 x 2000mm.

Drawer Capacity  
**100kg**  
Uniformly Distributed Load



**-4400P**



**-4401Q**



**-4402R**

| Product Number | Contents                           | No. of Shelves | Order Code BOT-405 | List Price/1 | Offer Price/1   |
|----------------|------------------------------------|----------------|--------------------|--------------|-----------------|
| 402.01.021.11V | -                                  | 3              | <b>-4400P</b>      | £871.00      | <b>£818.74</b>  |
| 402.01.023.11V | 2 drawers, half louvred back panel | 2              | <b>-4401Q</b>      | £973.00      | <b>£914.62</b>  |
| 402.01.024.11V | 6 drawers, half louvred back panel | 1              | <b>-4402R</b>      | £1215.00     | <b>£1142.10</b> |



Workshop Equipment



**Probe Industrial Cupboards**

All cupboard components are manufactured from mild steel. Shelf loading is a maximum of 85kg UDL.



**Standard Cupboard**

Supplied with three adjustable shelves, extra shelves available on request. Available in silver/blue, green, red, silver, white or yellow.



**NO CARRIAGE CHARGE**

\*Other colours available on request.

| Colour   | Description                   | Size (mm)        | Order Code* LSE-405 | Offer Price/1 |
|----------|-------------------------------|------------------|---------------------|---------------|
| Silver/* | Standard Cupboard Spare Shelf | 1780 x 915 x 460 | -6010_              | £276.70       |
|          |                               |                  | -6100K              | £15.41        |

**Cupboard/Wardrobe**

A useful combination of shelves and garment storage is created by a central partition. One side has three adjustable shelves while the other has a single shelf with hanging rail. Available in silver/blue, green, red, silver, white or yellow.



**NO CARRIAGE CHARGE**

\*Other colours available on request.

| Colour   | Description       | Size (mm)        | Order Code* LSE-405 | Offer Price/1 |
|----------|-------------------|------------------|---------------------|---------------|
| Silver/* | Cupboard/Wardrobe | 1780 x 915 x 460 | -6030_              | £310.13       |

**Low Cupboard**

Complete with one adjustable shelf, extra shelves available on request. Available in silver/blue, green, red, silver, white or yellow.



**NO CARRIAGE CHARGE**

\*Other colours available on request.

| Colour   | Description              | Size (mm)        | Order Code* LSE-405 | Offer Price/1 |
|----------|--------------------------|------------------|---------------------|---------------|
| Silver/* | Low Cupboard Spare Shelf | 1015 x 915 x 460 | -6050_              | £211.04       |
|          |                          |                  | -6100K              | £15.41        |

**\* OPTIONAL COLOURS \***

\*When choosing the colour for your doors, please add the 'suffix' stated below after the order code. e.g. for a Standard Cupboard with RED doors please order LSE-405-6010R

**Housing Paint Finish**  
Supplied on all units

**Silver**

**Standard Door Finish**  
Supplied unless specified otherwise

**Blue 'B'**

**Optional Door Finish**  
Supplied at no extra cost

**Green 'G'**

**Red 'R'**

**Silver 'S'**

**White 'W'**

**Yellow 'Y'**

Colours Shown are for Guidance Only

**12 Compartment Cupboard**

Features two partitions with nine adjustable shelves. Available in silver/blue, green, red, silver, white or yellow.



**10 - 15 Days**

**NO CARRIAGE CHARGE**

| Colour   | Description             | Size (mm)        | Order Code* LSE-405 | Offer Price/1 |
|----------|-------------------------|------------------|---------------------|---------------|
| Silver/* | 12 Compartment Cupboard | 1780 x 915 x 460 | -6040_              | £389.25       |

**Wardrobe Cupboard**

Complete with full width shelf and hanging rail. Available in silver/blue, green, red, silver, white or yellow.



**NO CARRIAGE CHARGE**

\*Other colours available on request.

| Colour   | Description                   | Size (mm)        | Order Code* LSE-405 | Offer Price/1 |
|----------|-------------------------------|------------------|---------------------|---------------|
| Silver/* | Wardrobe Cupboard Spare Shelf | 1780 x 915 x 460 | -6020_              | £263.51       |
|          |                               |                  | -6100K              | £15.41        |

**Tool Cupboard**

Complete with two adjustable shelves, extra shelves available on request. Fitted with a dished top to help retain tools and small items. Available in silver/blue, green, red, silver, white or yellow.



**NO CARRIAGE CHARGE**

\*Other colours available on request.

| Colour   | Description               | Size (mm)       | Order Code* LSE-405 | Offer Price/1 |
|----------|---------------------------|-----------------|---------------------|---------------|
| Silver/* | Tool Cupboard Spare Shelf | 890 x 460 x 460 | -6060_              | £106.69       |
|          |                           |                 | -6110K              | £7.60         |

Workshop Equipment

**PR OBE** Probe Lockers

Numbered card holder incorporating a lock cover which protects lockers from key scratches. Numbered cards available at extra cost. Even the standard lock has a micro sprung 10 disc lock featuring a massive 3000 serial combinations. Between each compartment the lockers have a welded plinth, making each compartment totally separate, increasing rigidity. A vent system allows each compartment to 'breathe'. Each locker has a full strengthener welded into the door to increase security. High visibility key, making identification easy. Available in silver/blue, green, red, silver, white or yellow.

NO CARRIAGE CHARGE



**OPTIONAL COLOURS**

\*When choosing the colour for your doors, please add the 'suffix' that is stated after the order code.

e.g. for a 3 door Std. locker with Green doors please order

**LSE-811-0030G**

|  |
|--|
| <b>Housing Paint Finish</b><br>Supplied on all units               |
| <b>Silver</b>  |
| <b>Standard Door Finish</b><br>Supplied unless specified otherwise |
| <b>Blue 'B'</b>  |
| <b>Optional Door Finish</b><br>Supplied at no extra cost           |
| <b>Green 'G'</b>   |
| <b>Red 'R'</b>   |
| <b>Silver 'S'</b>  |
| <b>White 'W'</b>   |
| <b>Yellow 'Y'</b>  |
| <small>Colours Shown are for Guidance Only</small>                 |

\*Other colours available on request.

**Standard Depth Lockers:**  
H1780 x W305 x D305mm

| No. of Doors  | Order Code* <b>LSE-811</b><br>Silver/* | Offer Price/1 |
|---------------|--|---------------|
| 1 Door Locker | -0010                                  | £85.25        |
| 2 Door Locker | -0020                                  | £111.53       |
| 3 Door Locker | -0030                                  | £120.99       |
| 4 Door Locker | -0040                                  | £129.36       |
| 5 Door Locker | -0050                                  | £138.52       |
| 6 Door Locker | -0060                                  | £159.51       |

**Deep Lockers:**  
H1780 x W305 x D460mm

| No. of Doors  | Order Code* <b>LSE-811</b><br>Silver/* | Offer Price/1 |
|---------------|--|---------------|
| 1 Door Locker | -0070                                  | £101.89       |
| 2 Door Locker | -0080                                  | £124.45       |
| 3 Door Locker | -0090                                  | £135.64       |
| 4 Door Locker | -0100                                  | £145.33       |
| 5 Door Locker | -0110                                  | £151.97       |
| 6 Door Locker | -0120                                  | £173.72       |

ALL ITEMS 10-15 Days

Workshop Equipment

**PR OBE** Probe Industrial Lockers

**Clean & Dirty Locker**

Complete with full internal top shelf 305mm high, vertical centre partition with two double coat hooks.

**Two Person Locker**

Provides two sections per user with separate keys to fit both. One small full width compartment at the top of the locker and vertical compartment fitted with a double coat hook.

**Janitorial Locker**

Complete with full internal top shelf 305mm high, vertical centre partition, double coat hook and a further three half width shelves.

**Twin Locker**

Each compartment comes with internal top shelf and a double coat hook.

**Cube Locker**

Air vent system on each door, standard 10 disc cam lock. Colours: silver/blue and also in grey.

**OPTIONAL COLOURS**

\*When choosing the colour for your doors, please add the 'suffix' stated below after the order code. e.g. for a Clean & Dirty Locker with Red doors please order

**LSE-811-0130R**

|  |
|--|
| <b>Housing Paint Finish</b><br>Supplied on all units               |
| <b>Silver</b>  |
| <b>Standard Door Finish</b><br>Supplied unless specified otherwise |
| <b>Blue 'B'</b>  |
| <b>Optional Door Finish</b><br>Supplied at no extra cost           |
| <b>Green 'G'</b>   |
| <b>Red 'R'</b>   |
| <b>Silver 'S'</b>  |
| <b>White 'W'</b>   |
| <b>Yellow 'Y'</b>  |
| <small>Colours Shown are for Guidance Only</small>                 |

Other colours available on request.



NO CARRIAGE CHARGE

CUBE LOCKERS

10 - 15 Days

ALL ITEMS

| Colour   | Description                   | Order Code* <b>LSE-811</b> | Offer Price/1 |
|----------|-------------------------------|----------------------------|---------------|
|          | Cube Locker 305 x 305 x 305mm | -0170                      | £45.86        |
| Silver/* | Cube Locker 380 x 380 x 380mm | -0180                      | £53.89        |
|          | Cube Locker 460 x 460 x 460mm | -0190                      | £59.74        |

| Colour   | Description            | Size (mm)        | Order Code* <b>LSE-811</b> | Offer Price/1 |
|----------|------------------------|------------------|----------------------------|---------------|
|          | Clean & Dirty Locker   | 1780 x 460 x 460 | -0130                      | £144.79       |
| Silver/* | 2 Person Locker        | 1780 x 380 x 460 | -0140                      | £180.75       |
|          | Uniform/Janitor Locker | 1780 x 460 x 460 | -0150                      | £163.27       |
|          | Twin Locker            | 1780 x 460 x 460 | -0160                      | £168.27       |

**MATLOCK** *Steel Lockers*

Powder coated durable steel lockers with reinforced doors, Strong semi-concealed hinges with deadlocks fitted as standard and through-frame locking for added security. Ventilation in frame allows air circulation whilst retaining unpierced door finish, hat shelf and 2 x coat hooks fitted in the single door locker (450mm deep locker also has a hanging rail), 2 x coat hooks fitted in each compartment of the 2-tier locker. BSI Quality Assured (meet the requirements of British Standard for Clothes Lockers BS4680:1996 'Standard Duty'). Delivery to UK mainland within 5 working days. **Contents not included.**



**NEW**



**BioCote**

All Matlock lockers are provided as standard with BioCote protection. BioCote is a patent-protected powder coating which inhibits the growth of potentially lethal bacteria and fungi. This reduces the risk of cross-contamination from surfaces with a high contact frequency.



| Colour | Description   | Size (mm)          | Order Code<br><b>MTL-405</b> | List Price/1 | Offer Price/1  |
|--------|---------------|--------------------|------------------------------|--------------|----------------|
| Grey   | 1 Door Locker | 1800 x 300 x 300mm | <del>-4210K</del>            | £99.99       | <b>£79.99</b>  |
|        | 2 Door Locker | 1800 x 300 x 300mm | <del>-4220K</del>            | £130.99      | <b>£104.79</b> |
|        | 3 Door Locker | 1800 x 300 x 300mm | <del>-4230K</del>            | £142.95      | <b>£114.36</b> |
|        | 4 Door Locker | 1800 x 300 x 300mm | <del>-4240K</del>            | £151.95      | <b>£121.56</b> |
|        | 1 Door Locker | 1800 x 300 x 450mm | <del>-4260K</del>            | £120.95      | <b>£96.76</b>  |
|        | 2 Door Locker | 1800 x 300 x 450mm | <del>-4270K</del>            | £147.95      | <b>£118.36</b> |
|        | 3 Door Locker | 1800 x 300 x 450mm | <del>-4280K</del>            | £160.95      | <b>£128.76</b> |
|        | 4 Door Locker | 1800 x 300 x 450mm | <del>-4290K</del>            | £170.95      | <b>£136.76</b> |

**CONTRACT PRICES AVAILABLE FOR VOLUME PURCHASES**

All Prices Exclude V.A.T. © 2011

Workshop Equipment

**bott** Tool  
Panels

Perfo products are designed to make optimum use of workshop space and are manufactured to withstand the most rigorous conditions, giving a long service life. The fully flanged metal panels are reinforced with channel backstrips and strengthened fixing points. All hooks lock into the panel with the Perfo locking clip, ensuring that hooks can be positioned quickly but remain securely located. Panels are supplied in pairs.



**-2345E**

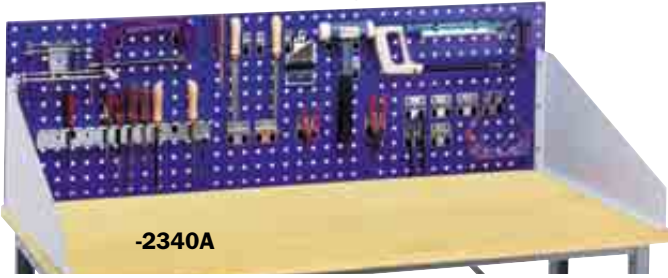

**-2340A**

| Product Number | Description | Width (mm) | Height (mm) | Order Code BOT-405 | List Price/1 | Offer Price/1 |
|----------------|-------------|------------|-------------|--------------------|--------------|---------------|
| 140 251 26.11  |             | 500        | 457         | <b>-2345E</b>      | £28.34       | <b>£26.64</b> |
| 140 251 28.11  | Tool Panel  | 1000       | 457         | <b>-2346F</b>      | £52.32       | <b>£49.18</b> |
| 140 251 29.11  | (pair)      | 1500       | 457         | <b>-2347G</b>      | £75.21       | <b>£70.70</b> |
| 140 251 30.11  |             | 2000       | 457         | <b>-2348H</b>      | £98.10       | <b>£92.21</b> |
| 140 251 75.16  | Bench Panel | 1500       | 457         | <b>-2340A</b>      | £54.50       | <b>£51.23</b> |
| 140 251 76.16  | Kit         | 2000       | 457         | <b>-2341B</b>      | £70.85       | <b>£66.60</b> |

**Freestanding Perfo Wall System**

Perfo Wall utilises upright members to provide support to standard Perfo panels. The design allows complete flexibility in the layout, 90° turns can be made, 'T' and '+' junctions are also possible. Supplied without hook accessories.

**PLEASE SELECT FROM PAGES 692 - 693.**

Available in 500mm and 1000mm widths, all models 1850mm high.

**Note:** all bays should be firmly fixed to the floor using the footplates supplied.



| Product Number | Width (mm) | Type                 | Order Code BOT-405 | List Price/Pr | Offer Price/Pr |
|----------------|------------|----------------------|--------------------|---------------|----------------|
| 14035019.11    | 500        | Single sided starter | <b>-2400R</b>      | £134.07       | <b>£126.03</b> |
| 14035020.11    | 500        | Double sided starter | <b>-2401S</b>      | £191.84       | <b>£180.33</b> |
| 14035027.11    | 500        | Single sided add on  | <b>-2403V</b>      | £116.63       | <b>£109.63</b> |
| 14035023.11    | 1000       | Single sided starter | <b>-2402T</b>      | £182.03       | <b>£171.11</b> |
| 14035044.11    | 1000       | Double sided starter | <b>-2405L</b>      | £285.58       | <b>£268.45</b> |
| 14035031.11    | 1000       | Single sided add on  | <b>-2404W</b>      | £163.50       | <b>£153.69</b> |
| 14035052.11    | 1000       | Double sided add on  | <b>-2405V</b>      | £268.14       | <b>£252.05</b> |

**Perfo Wall Cupboard**

Sturdy lockable wall cabinets for secure storage. Fully welded construction with a perforated back. The double skinned doors provide extra storage area and are secured by 2-point locking.

**Dimensions (W x D x H):**  
920 x 300 x 704mm



**-1814G**



**-1302C**

| Product Number | Description                                     | Weight | Order Code BOT-405 | List Price/1 | Offer Price/1  |
|----------------|---|--------|--------------------|--------------|----------------|
| 100 181 39.11  | Cupboard only (empty)                           | 26kg   | <b>-1800H</b>      | £186.39      | <b>£175.21</b> |
| 070 021 39.11  | Cupboard with 20 piece hook kit                 | 28kg   | <b>-1302C</b>      | £222.36      | <b>£209.02</b> |
| 100 185 05 11  | Cupboard with inner panels                      | 30kg   | <b>-1802K</b>      | £237.62      | <b>£223.36</b> |
| 100 187 80 11  | Cupboard with inner panels +20, +30 Fitting Kit | 35kg   | <b>-1814G</b>      | £301.11      | <b>£283.04</b> |

**Panel Trolleys**

These trolleys allow easy transportation around the workplace. The panels may be fitted upright or on a slight incline, the lower level may be omitted, to provide a useful storage space for toolcases or boxed items. **Dimensions (W x D x H):** 1000 x 650 x 1200 or 1600mm.



**-1301B**

| Product Number | Panels  | Height | Accessories       | Order Code BOT-405 | List Price/1 | Offer Price/1  |
|----------------|---------|--------|-------------------|--------------------|--------------|----------------|
| 104 030 33.11  | 4 Perfo | 1200   | Empty             | <b>-1840R</b>      | £378.23      | <b>£355.54</b> |
| 070 021 32.11  | 4 Perfo | 1200   | 40 Piece Hook Kit | <b>-1300A</b>      | £438.45      | <b>£412.14</b> |
| 140 260 26.11  | 6 Perfo | 1600   | Empty             | <b>-2361N</b>      | £467.61      | <b>£439.55</b> |
| 070 021 34.11  | 6 Perfo | 1600   | 60 Piece Hook Kit | <b>-1301B</b>      | £551.54      | <b>£518.45</b> |

**bott** *Heavy Duty Tool Storage System*

Heavy duty industrial cupboards with double locking doors. Finished in epoxy powder coat RAL7035 with doors in blue RAL5010. Perforated door liners will accept tool holders shown on pages 692 - 693. Security is ensured by a 3 point locking system. Shelves and drawers are adjustable on a 25mm pitch. Drawer dividers are available separately. Load capacity per shelf 160kg. Load capacity per drawer 100kg. Overall load capacity 1.5 ton.

**Dimensions (W x D x H):** 1050 x 650 x 2000mm.

**Cupboard Combinations**

Supplied with basic 2m high cupboard and two perforated door liners as standard.



**-4121G**



**-4130R**



**-4120F**



**-4122H**



**-4123J**

**Fittings**



**Drawer Kit -4600A**



**Shelf Kit -4800A**



**Wooden Worktop -4802C**

| Product Number | Fittings  | Order Code BOT-405 | List Price/1 | Offer Price/1   |
|----------------|---|--------------------|--------------|-----------------|
| 400 21 101.11V | 4x shelf  | <b>-4120F</b>      | £684.00      | <b>£642.96</b>  |
| 400 21 102.11V | Full perfo backpanel  | <b>-4121G</b>      | £632.00      | <b>£594.08</b>  |
| 400 21 108.11V | 4x 125mm drawer, 2x shelf   | <b>-4122H</b>      | £893.00      | <b>£839.42</b>  |
| 400 21 114.11V | 9x 125mm drawer, 3x shelf   | <b>-4123J</b>      | £1272.00     | <b>£1195.68</b> |
| 400 21 160.11V | 4x 125mm drawer, 1x shelf, 1x wood worktop 1xperfo backpanel, 1x louvre backpanel | <b>-4130R</b>      | £971.00      | <b>£912.74</b>  |

| Product Number | Kit Type | Order Code BOT-405 | List Price/1 | Offer Price/1 |
|----------------|----------|--------------------|--------------|---------------|
| 405 22 041     | Drawer   | <b>-4600A</b>      | £64.00       | <b>£60.16</b> |
| 421 01 019     | Shelf    | <b>-4800A</b>      | £32.00       | <b>£30.08</b> |
| 412 01 029     | Wood Top | <b>-4802C</b>      | £78.00       | <b>£73.32</b> |

**Steel Divider Kits**



| Product Number | To Suit Drawer | Number of Compartments | Order Code BOT-405 | List Price/1 | Offer Price/1 |
|----------------|----------------|------------------------|--------------------|--------------|---------------|
| 430 20 340.51V | 100/125mm      | 10                     | <b>-4980R</b>      | £37.00       | <b>£34.78</b> |
| 430 20 341.51V | 100/125mm      | 15                     | <b>-4981S</b>      | £49.00       | <b>£46.06</b> |
| 430 20 342.51V | 100/125mm      | 19                     | <b>-4982T</b>      | £58.00       | <b>£54.52</b> |

**Plastic Box Kits**



| Product Number | To Suit Drawer | Number of Compartments | Order Code BOT-405 | List Price/1 | Offer Price/1 |
|----------------|----------------|------------------------|--------------------|--------------|---------------|
| 430 20 187     | 100mm+         | 43                     | <b>-4920X</b>      | £58.80       | <b>£55.27</b> |
| 430 20 188     | 100mm+         | 61                     | <b>-4921Y</b>      | £73.50       | <b>£69.09</b> |
| 430 20 189     | 100mm+         | 79                     | <b>-4922Z</b>      | £87.15       | <b>£81.92</b> |

**CONTRACT PRICES AVAILABLE FOR VOLUME PURCHASES**

All Prices Exclude V.A.T. © 2011

Workshop Equipment

The accessories are quickly secured to our Perfo panels with our perfolock and may be repositioned at any time. All items are manufactured from steel and are zinc plated to give a long, corrosion resistant life. The standard kits provide easy selection and ordering for Perfo accessories. For custom layouts choose from our range of Perfo accessories. Securely fastened to panels in seconds with perfolock clips. Remove or reposition as required. Hook ends capped for safety.

**Hook Kit 140 314 10**

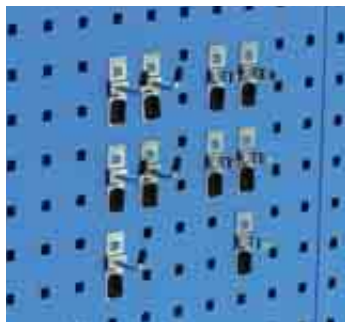

| Pack Qty | Order Code     | List Price/Pk | Offer Price/Pk |
|----------|----------------|---------------|----------------|
| 10       | <b>BOT-405</b> | £8.18         | <b>£7.69</b>   |

**Hook Kit 140 314 11**

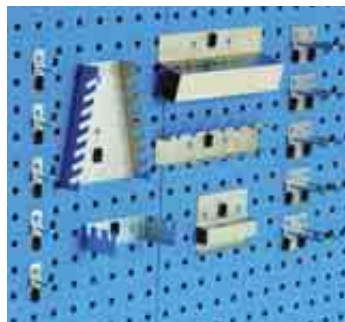

| Pack Qty | Order Code     | List Price/Pk | Offer Price/Pk |
|----------|----------------|---------------|----------------|
| 15       | <b>BOT-405</b> | £31.34        | <b>£29.46</b>  |

**Hook Kit 140 314 12**

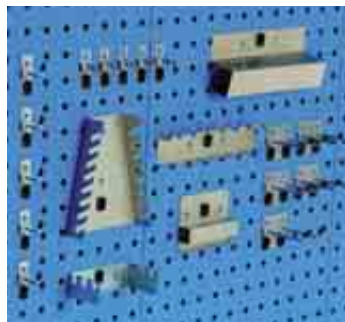

| Pack Qty | Order Code     | List Price/Pk | Offer Price/Pk |
|----------|----------------|---------------|----------------|
| 20       | <b>BOT-405</b> | £35.97        | <b>£33.81</b>  |

**Hook Kit 140 314 13**

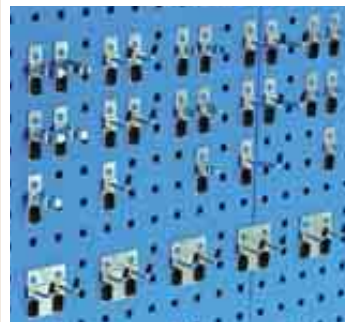

| Pack Qty | Order Code     | List Price/Pk | Offer Price/Pk |
|----------|----------------|---------------|----------------|
| 30       | <b>BOT-405</b> | £27.52        | <b>£25.87</b>  |

**Hook Kit 140 314 14**



| Pack Qty | Order Code     | List Price/Pk | Offer Price/Pk |
|----------|----------------|---------------|----------------|
| 40       | <b>BOT-405</b> | £60.22        | <b>£56.61</b>  |

**Hook Kit 140 314 15**



| Pack Qty | Order Code     | List Price/Pk | Offer Price/Pk |
|----------|----------------|---------------|----------------|
| 60       | <b>BOT-405</b> | £83.93        | <b>£78.89</b>  |

**Hook Kit 140 314 16**



| Pack Qty | Order Code     | List Price/Pk | Offer Price/Pk |
|----------|----------------|---------------|----------------|
| 80       | <b>BOT-405</b> | £109.55       | <b>£102.98</b> |

**Hexagon Key Holder 140 200 02**

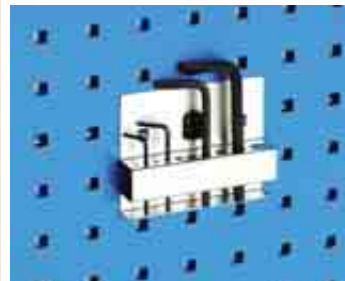

| Width (mm) | Order Code     | List Price/Pk | Offer Price/Pk |
|------------|----------------|---------------|----------------|
| 112        | <b>BOT-405</b> | £3.43         | <b>£3.22</b>   |

**Spanner Unit 140 170 02**

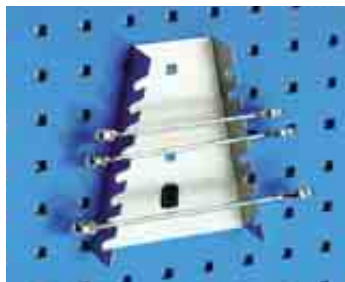

| Spanner Locations | Order Code     | List Price/1 | Offer Price/1 |
|-------------------|----------------|--------------|---------------|
| 7                 | <b>BOT-405</b> | £3.98        | <b>£3.74</b>  |

**Drill Holder 2.5 - 15mm Capacity 140 200 36**



| Width (mm) | Order Code     | List Price/1 | Offer Price/1 |
|------------|----------------|--------------|---------------|
| 225        | <b>BOT-405</b> | £6.10        | <b>£5.73</b>  |

**Screwdriver Unit 140 190 07**



| Width (mm) | Order Code     | List Price/Pk | Offer Price/Pk |
|------------|----------------|---------------|----------------|
| 225        | <b>BOT-405</b> | £4.09         | <b>£3.84</b>   |

**Hacksaw Storage Unit 140 190 03**

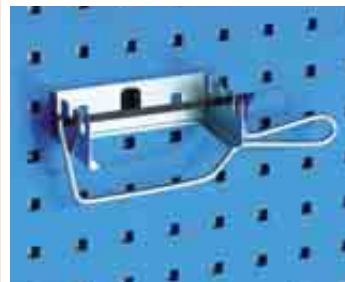

| Width (mm) | Order Code     | List Price/Pk | Offer Price/Pk |
|------------|----------------|---------------|----------------|
| 125        | <b>BOT-405</b> | £3.27         | <b>£3.07</b>   |

**Parts Shelf**



| Product Number    | Length (mm) | Order Code    | List Price/1 | Offer Price/1 |
|-------------------|-------------|---------------|--------------|---------------|
| <b>170mm Deep</b> |             |               |              |               |
| 14014034.16       | 450         | <b>-2275F</b> | £11.23       | <b>£10.56</b> |
| 14014006.16       | 900         | <b>-2270A</b> | £20.11       | <b>£18.90</b> |
| <b>250mm Deep</b> |             |               |              |               |
| 14014007.16       | 900         | <b>-2271B</b> | £27.74       | <b>£26.08</b> |
| 14014031.16       | 450         | <b>-2274E</b> | £15.70       | <b>£14.76</b> |

**Plastic Bin Storage Strips**



| Product Number | Width (mm) | Order Code    | List Price/1 | Offer Price/1 |
|----------------|------------|---------------|--------------|---------------|
| 14014043.16    | 100        | <b>-2278J</b> | £1.96        | <b>£1.84</b>  |
| 14014044.16    | 450        | <b>-2279K</b> | £5.18        | <b>£4.87</b>  |
| 14014045.16    | 900        | <b>-2280L</b> | £9.27        | <b>£8.71</b>  |

**Plier Hooks (Pack of 5)**



| Product Number | Width (mm) | Order Code    | List Price/Pk | Offer Price/Pk |
|----------------|------------|---------------|---------------|----------------|
| 14010015       | 35         | <b>-2221B</b> | £6.81         | <b>£6.40</b>   |
| 14010017       | 55         | <b>-2220A</b> | £7.09         | <b>£6.66</b>   |
| 14010019       | 75         | <b>-2222C</b> | £7.36         | <b>£6.92</b>   |

Workshop Equipment

**bott** Perfo Accessories

**Power Tool Loops (Pack of 5)**



| Product Number | Diameter (mm) | Order Code BOT-405 | List Price/Pk | Offer Price/Pk |
|----------------|---------------|--------------------|---------------|----------------|
| 14011016       | 40            | -2230H             | £8.45         | <b>£7.94</b>   |
| 14011018       | 60            | -2231J             | £8.72         | <b>£8.20</b>   |
| 14011020       | 80            | -2232K             | £8.99         | <b>£8.45</b>   |

**Tool Hooks**



**Single Tool Hook (Pack of 5)**

| Product Number | Length (mm) | Order Code BOT-405 | List Price/Pk | Offer Price/Pk |
|----------------|-------------|--------------------|---------------|----------------|
| 14001098       | 50          | -2200F             | £3.82         | <b>£3.59</b>   |
| 14001102       | 25          | -2201G             | £3.54         | <b>£3.33</b>   |
| 14001104       | 75          | -2202H             | £4.09         | <b>£3.84</b>   |
| 14001147       | 100         | -2205L             | £4.36         | <b>£4.10</b>   |
| 14001148       | 150         | -2206M             | £4.63         | <b>£4.35</b>   |

**Spring Clips**



**Single Spring Clip (Pack of 5)**

| Product Number | Diameter (mm) | Order Code BOT-405 | List Price/Pk | Offer Price/Pk |
|----------------|---------------|--------------------|---------------|----------------|
| 14013059       | 6             | -2260M             | £4.36         | <b>£4.10</b>   |
| 14013061       | 10            | -2250P             | £4.36         | <b>£4.10</b>   |
| 14013063       | 13            | -2251Q             | £4.63         | <b>£4.35</b>   |
| 14013065       | 16            | -2252R             | £4.63         | <b>£4.35</b>   |
| 14013067       | 19            | -2253S             | £4.63         | <b>£4.35</b>   |
| 14013069       | 25            | -2254T             | £4.63         | <b>£4.35</b>   |
| 14013071       | 28            | -2254W             | £5.18         | <b>£4.87</b>   |

**Combination Holder**



| Product Number | Size (W x D) (mm) | Order Code BOT-405 | List Price/1 | Offer Price/1 |
|----------------|-------------------|--------------------|--------------|---------------|
| 14022011       | 55 x 150          | -2335R             | £8.95        | <b>£8.41</b>  |



**Double Tool Hook (pack of 5)**

| Product Number         | Length (mm) | Order Code BOT-405 | List Price/Pk | Offer Price/Pk |
|------------------------|-------------|--------------------|---------------|----------------|
| <b>Double Vertical</b> |             |                    |               |                |
| 14002037               | 25          | -2210S             | £6.54         | <b>£6.15</b>   |
| 14002039               | 50          | -2211T             | £7.09         | <b>£6.66</b>   |
| 14002041               | 75          | -2212V             | £7.63         | <b>£7.17</b>   |
| 14002064               | 100         | -2214X             | £8.18         | <b>£7.69</b>   |
| 14002043               | 150         | -2213W             | £8.72         | <b>£8.20</b>   |



**Double Spring Clips (Pack of 5)**

| Product Number | Diameter (mm) | Order Code BOT-405 | List Price/Pk | Offer Price/Pk |
|----------------|---------------|--------------------|---------------|----------------|
| 14013075       | 2 x 6         | -2255V             | £6.99         | <b>£6.57</b>   |
| 14013077       | 2 x 10        | -2256W             | £7.12         | <b>£6.69</b>   |
| 14013079       | 2 x 13        | -2257X             | £7.24         | <b>£6.81</b>   |
| 14013081       | 2 x 16        | -2258Y             | £7.37         | <b>£6.93</b>   |
| 14013083       | 2 x 19        | -2259Z             | £7.42         | <b>£6.97</b>   |

**Panel and Clip Kits**

Each set is supplied with the illustrated Perfo® accessories (excluding tools). Additional components from the Perfo® range can be added to sets as required. Louvre panels.

**Tools not included**



-2387H



-2388J



-2390L



-2389K



-2391M

| Product Number | Size W x H (mm) | Hook Kit | Order Code BOT-405 | List Price/1 | Offer Price/1  |
|----------------|-----------------|----------|--------------------|--------------|----------------|
| 140.31.420.11  | (2x) 495 x 457  | 15 piece | -2387H             | £59.68       | <b>£56.10</b>  |
| 140.31.421.11  | (2x) 990 x 457  | 20 piece | -2388J             | £88.29       | <b>£82.99</b>  |
| 140.31.422.11  | (4x) 990 x 457  | 40 piece | -2389K             | £164.86      | <b>£154.97</b> |
| 140.31.424.11  | (4x) 1486 x 457 | 60 piece | -2390L             | £234.35      | <b>£220.29</b> |
| 140.31.425.11  | (6x) 1486 x 457 | 80 piece | -2391M             | £335.18      | <b>£315.07</b> |

**CONTRACT PRICES AVAILABLE FOR VOLUME PURCHASES**

All Prices Exclude V.A.T. © 2011

Workshop Equipment

**MATLOCK** QuickRack™ Industrial Racking



Easy assembly shelving offering a fast and economic solution to storage and production problems. Shelves slot and lock into uprights removing the need for fasteners, fixings and tools. Supplied with 18mm chipboard shelves. Extra shelves are available on request. Shelving can be designed to suit your space requirements. Connector plates are required to construct shelving runs (four plates per join).

**Standard Duty**

Ideal for light to medium weight storage of archive boxes, bankers boxes, box files, arch files, magazine holders, paint tins and boxes of stock. Contents: four uprights, five shelf levels with J-beams, feet and assembly instructions. Supplied as graphite grey uprights with light grey shelves.

**Maximum bay load:** 2000kg (uniformly distributed).



**Corrugated Cartons**

**See Group 830**

**Euro Boxes**

**See Page 696**

Workshop Equipment

Up To **1500kg** Capacity

**UDL Per Bay**

**SELF ASSEMBLY**  
Tools Required

Shelf Capacity

**360kg**

**Simple Assembly**

No clips, nuts & bolts or screws

**7-10 Days**

**Complete Shelving Bays**

Consists of five shelves and four uprights.

| Size (mm)         | Blue/Grey Order Code <b>MTL-405</b> | Red/Grey Order Code <b>MTL-405</b> | Grey/Grey Order Code <b>MTL-405</b> | List Price/1 | Offer Price/1  |
|-------------------|-------------------------------------|------------------------------------|-------------------------------------|--------------|----------------|
| 1980 x 900 x 300  | <b>-2560K</b>                       | <b>-2570K</b>                      | <b>-2550K</b>                       | £132.66      | <b>£106.13</b> |
| 1980 x 900 x 450  | <b>-2510K</b>                       | <b>-2520K</b>                      | <b>-1100K</b>                       | £145.97      | <b>£116.78</b> |
| 1980 x 1200 x 300 | <b>-2590K</b>                       | <b>-2600K</b>                      | <b>-2580K</b>                       | £159.84      | <b>£127.87</b> |
| 1980 x 1200 x 450 | <b>-2530K</b>                       | <b>-2540K</b>                      | <b>-1120K</b>                       | £179.44      | <b>£143.55</b> |

**Additional Shelves**

Each shelf consists of four steel sides and one 18mm thick chipboard sheet.

| Size W x D             | Max. Shelf Load | Order Code <b>MTL-405</b> | List Price/1 | Offer Price/1 |
|------------------------|-----------------|---------------------------|--------------|---------------|
| 900 x 300mm            | 360kg           | <b>-2900K</b>             | £18.17       | <b>£14.54</b> |
| 900 x 450mm            | 320kg           | <b>-1110K</b>             | £30.91       | <b>£24.73</b> |
| 1200 x 300mm           | 350kg           | <b>-2910K</b>             | £23.60       | <b>£18.88</b> |
| 1200 x 450mm           | 350kg           | <b>-1130K</b>             | £38.64       | <b>£30.91</b> |
| Shelving Bay Connector | -               | <b>-1500K</b>             | £2.90        | <b>£2.32</b>  |

**Heavy Duty Boltless Shelving**

Available in a choice of 900mm or 1200mm width. Five shelves made of high density 15mm thick particle board. With the unit fixed with screws to a wall, each shelf can take up to 350kg UDL (uniformly distributed load). Interlocking parts only-no nuts and bolts! Thick strong steel uprights and beams with a powder coated finish. Supplied with eight rubber foot pieces to protect the floor



**SELF ASSEMBLY**  
Tools Required

TWO WAYS OF ASSEMBLING: One full rack with five shelves, 198cm high, or two halves three & two shelves, each 99cm high.

**OUR LOWEST PRICED SHELVING EVER!**

Shelf Capacity

**350kg**

**NEW**



| Size H (max) x W x D | Max. Shelf Capacity | Order Code <b>PRO-405</b> | List Price/1 | Offer Price/1 |
|----------------------|---------------------|---------------------------|--------------|---------------|
| 1980 x 900 x 450mm   | 350kg               | <b>-3010A</b>             | £76.46       | <b>£64.99</b> |
| 1980 x 1200 x 450mm  | 350kg               | <b>-3020A</b>             | £82.34       | <b>£69.99</b> |



**MATLOCK** QuickRack™  
Industrial Racking

Easy assembly shelving offering a fast and economic solution to storage and production problems. Shelves slot and lock into uprights removing the need for fasteners, fixings and tools. Supplied with 18mm chipboard shelves. Extra shelves are available on request. Shelving can be designed to suit your space requirements. Connector plates are required to construct shelving runs (four plates per join).

**Heavy Duty**

Ideal for medium to heavy weight storage of tools and components. Contents: four uprights, three shelf levels with channel beams, feet and assembly instructions. Supplied as graphite grey uprights with light grey shelf beams.

**Maximum bay load: 3000kg**  
(uniformly distributed).

**EXTENDED RANGE**

Up To **3000kg**  
Capacity  
**UDL Per Bay**

Shelf Capacity  
**510kg**

**7-10 Days**

**SELF ASSEMBLY**  
Tools  
Required

**Simple Assembly**  
No clips, nuts & bolts or screws



**Complete Shelving Bays**

Consists of three shelves and four uprights.

| Size (mm)         | Blue/Grey Order Code MTL-405 | Red/Grey Order Code MTL-405 | Grey/Grey Order Code MTL-405 | List Price/1 | Offer Price/1 |
|-------------------|------------------------------|-----------------------------|------------------------------|--------------|---------------|
| 1980 x 1500 x 450 | -2720K                       | -1140K                      | -2710K                       | £182.33      | £145.86       |
| 1980 x 1500 x 600 | -2740K                       | -1160K                      | -2730K                       | £196.07      | £156.86       |
| 1980 x 1800 x 600 | -2760K                       | -1180K                      | -2750K                       | £211.65      | £169.32       |
| 1980 x 1800 x 900 | -2780K                       | -1200K                      | -2770K                       | £251.09      | £200.87       |
| 1980 x 2400 x 600 | -2800K                       | -2810K                      | -2790K                       | £244.73      | £195.78       |
| 1980 x 2400 x 900 | -2830K                       | -2840K                      | -2820K                       | £291.30      | £233.04       |

**Additional Shelves**

Each shelf consists of four steel sides and one 18mm thick chipboard sheet.

| Size W x D   | Max. Shelf Load | Order Code MTL-405 | List Price/1 | Offer Price/1 |
|--------------|-----------------|--------------------|--------------|---------------|
| 1500 x 450mm | 510kg           | -1150K             | £46.37       | £37.10        |
| 1500 x 600mm | 275kg           | -1170K             | £54.11       | £43.29        |
| 1800 x 600mm | 365kg           | -1190K             | £74.20       | £59.36        |
| 1800 x 900mm | 210kg           | -1210K             | £92.76       | £74.21        |
| 2400 x 600mm | 445kg           | -2920K             | £63.67       | £50.94        |
| 2400 x 900mm | 210kg           | -2930K             | £78.99       | £63.19        |

**Archive Bays**

Simple, strong and excellent value document storage bays offer easy record storage and retrieval. Assembles in minutes without nuts, bolts or rivets. Prices include boxes. Bays comprise of four uprights in choice of three colours, three shelf levels with 18mm FSC compliant chipboard supported by light grey channel and metal footplates. Assembly instructions included.

**Maximum shelf load: 210kg.**

Shelf Capacity  
**210kg**

**7-10 Days**

**SELF ASSEMBLY**  
Tools  
Required

| Type | Size (mm)     | Blue/Grey Order Code MTL-405 | Red/Grey Order Code MTL-405 | Grey/Grey Order Code MTL-405 | List Price/1 | Offer Price/1 |
|------|---------------|------------------------------|-----------------------------|------------------------------|--------------|---------------|
| 30   | 2050x1800x450 | -2010K                       | -2020K                      | -2030K                       | £356.26      | £285.01       |
| 35   | 2270x1800x450 | -2040K                       | -2050K                      | -2060K                       | £385.19      | £308.15       |
| 60   | 2050x1800x900 | -2070K                       | -2080K                      | -2090K                       | £591.66      | £473.33       |
| 70   | 2270x1800x900 | -2100K                       | -2110K                      | -2120K                       | £655.86      | £524.69       |



**CONTRACT PRICES AVAILABLE FOR VOLUME PURCHASES**

All Prices Exclude V.A.T. © 2011

Workshop Equipment

Under the Health and Safety Regulations 1981, workplaces must have first aid provision. To satisfy a wide range of first aid equipment we have designed an attractive and highly visible range of Probe cabinets for your working environment. Strong robust construction. All cabinets feature adjustable shelves. Two point locking on all cabinet doors. High visibility 270° labelling complying to **BS5499-1**. Reinforced doors for extra strength.

**ACTIVECOAT** anti-bacterial technology **THE** hard wearing anti-bacterial powder coating for the most stringent hygienic environment.

**ACTIVECOAT** is a new, hard wearing, patent-protected powder coating containing elemental Silver ionically bonded into a bio-compatible ceramic material known as a Zeolite. This impedes the growth and migration of potentially harmful bacteria, mould, fungi, algae and more reducing the risk of cross-contamination from surface to surface. Especially suitable where stringent hygiene standards are required, such as health care, educational, catering and retail changing rooms.

- **99.9% Reduction of E-COLI & MRSA Super Bug.**
- **Independently tested.**
- **100% Safe to humans.**
- **Effective for the life of the coating.**

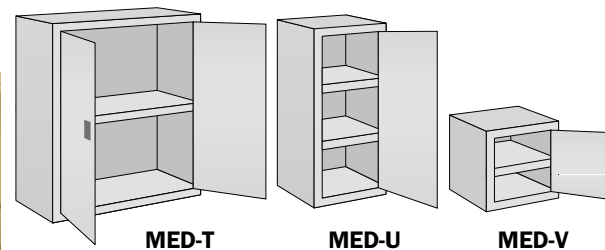

| Product Number | Description           | External Dimensions (H x W x D) | No. of Shelves | Weight | Volume | Order Code               | Offer Price/1  |
|----------------|-----------------------|---------------------------------|----------------|--------|--------|--------------------------|----------------|
| MED-T          | Low Medical Cabinet   | 1015 x 915 x 460                | 1              | 40kg   | 42ltr  | <b>LSE-405</b><br>-5030K | <b>£315.15</b> |
| MED-U          | Small Medical Cabinet | 890 x 460 x 460                 | 2              | 22kg   | 18ltr  | -5040K                   | <b>£151.76</b> |
| MED-V          | Cube Medical Cabinet  | 460 x 460 x 460                 | 1              | 8kg    | 9ltr   | -5050K                   | <b>£96.73</b>  |

### Hazardous Substance Cupboards

A range of lockable welded steel cabinets for storing flammable substances near the work place, designed to comply with current UK regulations and guidelines. COSHH requirements. Yellow powder coated finish. Fitted internally with leak-proof shelves. BS labelling. Leak-proof welded construction in 0.9mm steel with base spillage sump. Rebated reinforced doors with three way locking chrome lever handle. All cabinet assemblies supplied finished powder coated yellow with suitable warning labels. All shelves/trays are adjustable. 30 min fire rating.

#### Compliant with The Dangerous Substances and Explosive Atmospheres Regulations 2002.

We can offer a full range of acid, pesticide and PPE storage cabinets on request.

#### Cabinets

Finished in safety yellow with warning signs to **BS 5378**. Shelves are adjustable for height. Liquid tight base to collect any spillage or leakage. 20SWG steel construction.

#### Bins

Sloping top welded steel storage unit for small quantities of flammable substances. Lids can be locked in closed position by padlock. Manufactured in 20SWG steel finished in safety yellow with warning signs to **BS 5378**.

A complete range of hazardous substance control products are available, including spill control pallets, anti-static wires, liquid disposal cans, salvage drums and customised cabinets. Further details on request.



| Model Number              | Description | Dimensions H x W x D (mm) | Number of |         | Weight each | Order Code    | Offer Price/1  |
|---------------------------|-------------|---------------------------|-----------|---------|-------------|---------------|----------------|
|                           |             |                           | Doors     | Shelves |             |               |                |
| 28/14                     |             | 710 x 355 x 305           | 1         | 2       | 17.0kg      | <b>-1028A</b> | <b>£206.00</b> |
| 36/18                     | Cabinet     | 915 x 460 x 460           | 1         | 1       | 25.0kg      | <b>-1036B</b> | <b>£187.00</b> |
| 36/36                     | Type HSC    | 915 x 915 x 460           | 2         | 1       | 36.0kg      | <b>-1040C</b> | <b>£272.00</b> |
| 72/36                     |             | 1830 x 915 x 460          | 2         | 3       | 72.0kg      | <b>-1072D</b> | <b>£397.00</b> |
| 26/24                     | Bins        | 660 x 610 x 330           | -         | -       | 20.0kg      | <b>-2020E</b> | <b>£251.00</b> |
| 30/46                     | Type HSB    | 760 x 1170 x 460          | -         | -       | 41.0kg      | <b>-2024F</b> | <b>£353.00</b> |
| Optional Stand for S36/36 |             | 35 x 915 x 460            | -         | -       | 10.0kg      | <b>-2500A</b> | <b>£90.00</b>  |

**bott Aluminium Tool Chests**

This range of containers is manufactured from aluminium, giving tremendous strength combined with light weight. Ideal for transportation and storage of valuable or delicate items where weight is an important issue, such as air freight.

- Ribbed body for high strength with light weight.
- Tough grip handles - weight capacity 35kg per handle.
- Recessed base prevents ingress of moisture if stood on wet floor.
- Retaining strap on lid prevents hinge damage.
- Rubber seal between body and lid helps to keep dust out.
- Corner forms ensure stacked boxes are securely located.
- Durable and attractive raw aluminium finish.
- Over centre hasps may be wired or padlocked to increase security.



**Corner Locators and Hasps**

**Strengthening Ribs and Handles**

**Lid Restraint Straps and Lid Seal**



All boxes with the exception of the A833 and A930, are based around Europallet dimensions and are designed to stack and interstack. 2 x A620 boxes have the same base area as an A840 box, and 2 x A840 boxes have the same base area as an A1250.

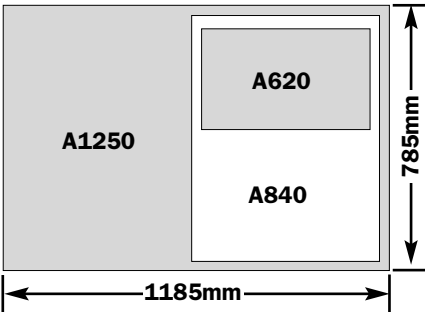

**For Portable Tool Boxes**

**See Group 593**



| Model | External Dimensions W x D X H (mm) | Internal Dimensions W x D X H (mm) | Capacity Litres | Weight (kg) | Order Code BOT-406 | List Price/1 | Offer Price/1 |
|-------|------------------------------------|------------------------------------|-----------------|-------------|--------------------|--------------|---------------|
| A620  | 585 x 385 x 250                    | 550 x 350 x 220                    | 42              | 4.5         | -1001A             | £128.18      | £120.49       |
| A640  | 585 x 385 x 410                    | 550 x 350 x 380                    | 73              | 5.3         | -1002B             | £152.36      | £143.22       |
| A833  | 785 x 385 x 340                    | 750 x 350 x 310                    | 81              | 6.1         | -1003C             | £169.27      | £159.11       |
| A840  | 785 x 585 x 410                    | 750 x 550 x 380                    | 156             | 8.1         | -1004D             | £224.91      | £211.42       |
| A860  | 785 x 585 x 610                    | 750 x 550 x 580                    | 239             | 9.6         | -1005E             | £246.73      | £231.93       |
| A930  | 885 x 485 x 380                    | 850 x 450 x 350                    | 133             | 7.7         | -1006F             | £212.73      | £199.97       |
| A1250 | 1185 x 785 x 510                   | 1150 x 750 x 480                   | 414             | 15.4        | -1007G             | £440.00      | £413.60       |

**Steel Tool Chests**

Big tough tool chests manufactured in heavy gauge steel, finished in chip and scratch-resistant powder coating. No-nonsense chests suited to the professional environment. Tough sheet steel body. Fully welded construction. Removable parts tray for smaller items. Wrap over lid makes shower-proof container. Hasp and staple lock (padlock not included). Integral hinge protector plate with stop to prevent lid over opening. Double grab handle. Lined with quality board to protect tools and prevent internal damage to box (except P640). Heavy duty construction offers the ideal toolbox for the harshest conditions.

**For Van Vaults**

**See Group 593**



| Model No. | Dimensions H x W x D (mm) | Weight each | Order Code BOT-405 | List Price/1 | Offer Price/1 |
|-----------|---------------------------|-------------|--------------------|--------------|---------------|
| P640      | 232 x 640 x 232           | 7.0kg       | -1020A             | £67.83       | £63.76        |
| U700      | 312 x 690 x 360           | 15.0kg      | -1021B             | £93.45       | £87.84        |
| U830      | 343 x 833 x 440           | 20.0kg      | -1022C             | £110.90      | £104.25       |
| U910      | 432 x 910 x 532           | 28.5kg      | -1023D             | £139.85      | £131.46       |
| U1000     | 312 x 990 x 360           | 19.0kg      | -1024E             | £108.00      | £101.52       |

**CONTRACT PRICES AVAILABLE FOR VOLUME PURCHASES**

All Prices Exclude V.A.T. © 2011

Workshop Equipment

GROUP 405 WOODWORKING BENCHES

**KENNEDY** Portable Bench & Vice  
QUALITY INDUSTRIAL TOOLING

Rapid clamping. Full graduated working surface with channelled chuck block guides. Includes four adjustable chuck blocks and 4 profile blocks. Aluminium mitre guides and lower support arm to assist power tool use. Rapid fold/unfold with quick lock and release action, compact and easy to store.



**For Dust Masks**



**See Group 959**



Rapid clamping



Aluminium mitre guide



Lower support arm



Mitre clamping



Rapid fold/unfold with auto lock

**For Power Tools**



**See Group 279**

| Description                    | Order Code               | List Price/1 | Offer Price/1  |
|--------------------------------|--------------------------|--------------|----------------|
| 4 in 1 portable workbench      | <b>KEN-405</b><br>-4600K | £127.00      | <b>£115.57</b> |
| <b>Spare Parts</b>             |                          |              |                |
| Spare clamping block           | -4610K                   | £3.51        | <b>£3.51</b>   |
| Replacement Rubber Feet (pk 4) | -4620K                   | £3.68        | <b>£3.68</b>   |

Workshop Equipment

**Portable Bench Top Workstation**

Includes two trays to store tools & small parts. Full graduated working surface with channelled chuck block guides. Includes four adjustable chuck blocks and profile adaptor blocks. Mounting holes in the feet of the workstation allow it to be fitted to a workbench if required. Compact, portable with carry handle and easy to store.



Storage trays



Mitre clamping



Compact, portable & easy to store



Fully graduated working surface



| Description                      | Order Code               | List Price/1 | Offer Price/1 |
|----------------------------------|--------------------------|--------------|---------------|
| 4 in 1 portable workbench        | <b>KEN-405</b><br>-4700K | £51.95       | <b>£47.27</b> |
| <b>Spare Parts</b>               |                          |              |               |
| Spare clamping block             | -4610K                   | £3.51        | <b>£3.51</b>  |
| Spare clamping handle c/w sleeve | -4720K                   | £3.68        | <b>£3.68</b>  |

**SENATOR** Home Improver  
QUALITY TOOLING Workbench & Vice



Medium duty for hobby and DIY use. All steel body. Solid beech worktop with metric/imperial gauging scale and protractor markings. Easy to assemble. Sturdy splay legs with non-slip rubber feet. Four quick-change worktop functions. Supplied with four chuck blocks, assembly spanners and instructions.

- Worktop width:** 600mm.
- Worktop depth (individual):** 115mm.
- Worktop depth (combined):** 230mm.
- Overall height:** 800mm.
- Width (when collapsed for storage):** 280mm.
- Maximum opening capacity:** 140mm.
- Maximum clamping capacity (with blocks):** 285mm.
- Weight capacity:** 200kg/440lbs.



For Woodworking Tools



Transforms to an upright vice with jaws set at 90°.



Transforms to a versatile saw horse with jaws set at 45°.



Ideal for clamping pipe and other convex workpieces.



Independent arm adjustment allows the clamping of tapered objects.



Transforms to a T vice.

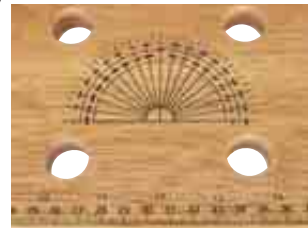

Solid Hardwood worktop with protractor and rule markings.

| Height (mm) | Width (mm) | Weight each | Order Code                      | List Price/1 | Offer Price/1 |
|-------------|------------|-------------|---------------------------------|--------------|---------------|
| 800         | 600        | -           | <b>SEN-405</b><br><b>-9650K</b> | £24.99       | <b>£19.99</b> |

**SIP** Professional Oak  
Woodworking Bench

High quality solid oak construction. Harder wearing than standard softwood models. Supplied flat packed for self assembly. Ideally suited for use in workshops, colleges and garages. Competitively priced to appeal to all types of user. Bench incorporates two wooden vices constructed from the same high quality oak as the bench itself.

- Packed dimensions:** W1410 x H530 x D140mm. **Gross weight:** 33.5kg.
- Assembled dimensions:** W1265 x H840 x D630mm. **Net weight:** 30.0kg.



Supplied with four removable dogs to allow larger work pieces to be held.



Single central waist level drawer - For convenient storage of tools.



Low level full length storage shelf - For bulkier items



Low level full length storage shelf - For bulkier items



For Saw Tables

See Group **277**

| Model Number | Weight (each) | Order Code    | List Price/1 | Offer Price/1  |
|--------------|---------------|---------------|--------------|----------------|
| 01441        | 33.5kg        | <b>-0400A</b> | £169.42      | <b>£135.54</b> |

CONTRACT PRICES AVAILABLE FOR VOLUME PURCHASES

Workshop Equipment

**GROUP 405 WORKBENCHES & CABINETS**

**bott Engineer's Fully Welded Workbenches**

Fully welded benches available mobile or static - delivered ready to use. Choice of regular 2mm steel plate worktop or 20mm Beech layered worktop. Long life epoxy powder coat. Heavy duty steel framework with base shelf. Cupboards supplied with shelf, adjustable on 3 fixed levels. All cupboards and drawers are lockable. Handle fitted to all mobile units. 125mm diameter castor set on mobile units. All units are 600mm deep and 910mm high.



**1000mm Wide Workbenches**

**Basic Bench**



| Product Number | Type   | Worktop Finish | Order Code BOT-405 | List Price/1 | Offer Price/1  |
|----------------|--------|----------------|--------------------|--------------|----------------|
| 169 01 803     | Static | Mpx            | -2781N             | £285.00      | <b>£267.90</b> |
| 169 01 805     | Mobile | Mpx            | -2783Q             | £355.25      | <b>£333.94</b> |
| 169 01 802     | Static | Steel          | -2780M             | £243.00      | <b>£228.42</b> |
| 169 01 804     | Mobile | Steel          | -2782P             | £313.25      | <b>£294.45</b> |

**1500mm Wide Workbenches**

**Basic Bench**



| Product Number | Type   | Worktop Finish | Order Code BOT-405 | List Price/1 | Offer Price/1  |
|----------------|--------|----------------|--------------------|--------------|----------------|
| 169 01 809     | Static | Mpx            | -2785S             | £338.00      | <b>£317.72</b> |
| 169 01 808     | Static | Steel          | -2784R             | £278.00      | <b>£261.32</b> |

**Bench with Cupboard**



| Product Number | Type   | Worktop Finish | Order Code BOT-405 | List Price/1 | Offer Price/1  |
|----------------|--------|----------------|--------------------|--------------|----------------|
| 169 01 855     | Static | Mpx            | -2793D             | £388.25      | <b>£321.95</b> |
| 169 01 857     | Mobile | Mpx            | -2795F             | £458.50      | <b>£430.99</b> |
| 169 01 854     | Static | Steel          | -2792C             | £346.25      | <b>£325.48</b> |
| 169 01 856     | Mobile | Steel          | -2794E             | £416.50      | <b>£391.51</b> |

**Bench with Cupboard**



| Product Number | Type   | Worktop Finish | Order Code BOT-405 | List Price/1 | Offer Price/1  |
|----------------|--------|----------------|--------------------|--------------|----------------|
| 169 01 858     | Static | Mpx            | -2797H             | £453.75      | <b>£426.52</b> |
| 169 01 859     | Static | Steel          | -2796G             | £393.25      | <b>£369.65</b> |

**Bench with Drawer**



| Product Number | Type   | Worktop Finish | Order Code BOT-405 | List Price/1 | Offer Price/1  |
|----------------|--------|----------------|--------------------|--------------|----------------|
| 169 01 851     | Static | Mpx            | -2791B             | £342.50      | <b>£321.95</b> |
| 169 01 861     | Mobile | Mpx            | -2799K             | £412.75      | <b>£387.99</b> |
| 169 01 850     | Static | Steel          | -2790A             | £300.50      | <b>£282.47</b> |
| 169 01 860     | Mobile | Steel          | -2798J             | £370.75      | <b>£348.50</b> |

**Bench with Drawer**



| Product Number | Type   | Worktop Finish | Order Code BOT-405 | List Price/1 | Offer Price/1  |
|----------------|--------|----------------|--------------------|--------------|----------------|
| 169 01 863     | Static | Mpx            | -2801M             | £396.00      | <b>£372.24</b> |
| 169 01 862     | Static | Steel          | -2800L             | £335.00      | <b>£314.90</b> |

Workshop Equipment

**SENATOR**  
QUALITY TOOLING

**Cabinet with Shelf & Workbench**

Manufactured from cold rolled steel plate with a hard wearing corrosion resistant powder coated finish. Hard wearing solid wooden work surface. Two shelves. Adjustable feet. Supplied with assembly instructions.  
**Maximum shelf capacity:** 20kg.  
**Maximum cabinet capacity:** 150kg.



SELF ASSEMBLY  
Tools Required

2 - 3 Days

| Dimensions (W x D x H) | Weight | Order Code | List Price/1 | Offer Price/1 |
|------------------------|--------|------------|--------------|---------------|
| 838x508x852            | 25.5kg | SEN-405    | £94.99       | £75.99        |

**Locking Cabinet & Workbench**

Lockable storage cabinet with two shelves.  
**Overall dimensions (W x D x H):** 838 x 508 x 852mm.  
**Max shelf capacity:** 20kg.  
**Max cabinet capacity:** 150kg.



SELF ASSEMBLY  
Tools Required

2 - 3 Days

| Dimensions (W x D x H) | Weight | Order Code | List Price/1 | Offer Price/1 |
|------------------------|--------|------------|--------------|---------------|
| 838x508x852            | 27.0kg | SEN-405    | £99.99       | £79.99        |

**5 Drawer Cabinet & Workbench**

The five drawers have a smooth action sliding mechanism.



SELF ASSEMBLY  
Tools Required

2 - 3 Days

| Dimensions (W x D x H) | Weight | Order Code | List Price/1 | Offer Price/1 |
|------------------------|--------|------------|--------------|---------------|
| 838x508x852            | 43.0kg | SEN-405    | £199.95      | £159.96       |

**Locking Cabinet with Shelf & Workbench**

Lockable storage cabinet with two shelves and two open shelves for additional storage.  
**Overall dimensions (W x D x H):** 1372 x 508 x 865mm.  
**Max shelf/drawer capacity:** 25kg.  
**Max cabinet capacity:** 180kg.

Shelf Capacity  
**25kg**  
 Uniformly Distributed Load



SELF ASSEMBLY  
Tools Required

2 - 3 Days

| Dimensions WxDxH (mm) | Weight | Order Code | List Price/1 | Offer Price/1 |
|-----------------------|--------|------------|--------------|---------------|
| 1372x508x865          | 48.5kg | SEN-405    | £269.95      | £215.96       |

**5 Drawer Cabinet & Shelved Workbench**

The five drawers have a smooth action sliding mechanism. Two open shelves for additional storage.  
**Overall dimensions (W x D x H):** 1372 x 508 x 865mm.  
**Max shelf drawer capacity:** 25kg.  
**Max cabinet capacity:** 180kg.

Shelf Capacity  
**25kg**  
 Uniformly Distributed Load



SELF ASSEMBLY  
Tools Required

2 - 3 Days

| Dimensions WxDxH (mm) | Weight | Order Code | List Price/1 | Offer Price/1 |
|-----------------------|--------|------------|--------------|---------------|
| 1372x508x865          | 61.0kg | SEN-405    | £299.95      | £239.96       |

**KENNEDY**  
QUALITY INDUSTRIAL TOOLING  
**2 Drawer Workbench**

Professional quality two drawer workbench constructed from heavy gauge steel for sturdy long-term use. Ideal for a range of workshop and industrial applications. Drawers are lockable and fitted with smooth glide drawer runners. Full length storage shelf. Quick and easy assembly. Powder coated finish.  
**Dimensions (W x D x H):** 1500 x 640 x 865mm.



Shelf Capacity  
**40kg**  
 Uniformly Distributed Load

SELF ASSEMBLY  
Tools Required

2 - 3 Days

| Dimensions (W x D x H) | Weight | Order Code | List Price/1 | Offer Price/1 |
|------------------------|--------|------------|--------------|---------------|
| 1500x640x865           | 77.4kg | KEN-405    | £219.00      | £199.29       |

**GROUP 405 WORKBENCHES & CABINETS**

**bot Bott Verso Storage Benches**

30mm thick multiplex worktops. Lockable cupboards. All benches are supplied fully assembled ready for immediate use. All models are 600mm deep and height adjustable from 780 - 930mm



Drawer dividers available - call for details.



**Width 1250mm**

2x 125mm high drawer, 2x cupboard.



| Product Number | Order Code    | List Price/1 | Offer Price/1  |
|----------------|---------------|--------------|----------------|
| 169 02 001.11V | <b>-2850A</b> | £497.70      | <b>£467.84</b> |

**Width 1250mm**

1x 125mm, 2x 175mm high drawers, 1x cupboard.



| Product Number | Order Code    | List Price/1 | Offer Price/1  |
|----------------|---------------|--------------|----------------|
| 169 02 003.11V | <b>-2851B</b> | £514.50      | <b>£483.63</b> |

**Width 1250mm**

2x 125mm, 4x 175mm high drawers.



| Product Number | Order Code    | List Price/1 | Offer Price/1  |
|----------------|---------------|--------------|----------------|
| 169 02 004.11V | <b>-2852C</b> | £634.20      | <b>£596.15</b> |

**Width 1500mm**

1x 125mm, 2x 175mm high drawers, 1x storage area with shelf.



| Product Number | Order Code    | List Price/1 | Offer Price/1  |
|----------------|---------------|--------------|----------------|
| 169 02 023.11V | <b>-2853D</b> | £546.53      | <b>£513.74</b> |

**Width 1500mm**

1x 125mm, 2x 175mm high drawers, 1x cupboard.



| Product Number | Order Code    | List Price/1 | Offer Price/1  |
|----------------|---------------|--------------|----------------|
| 169 02 024.11V | <b>-2854E</b> | £557.55      | <b>£524.10</b> |

**Width 1500mm**

2x 125mm, 4x 175mm high drawers.



| Product Number | Order Code    | List Price/1 | Offer Price/1  |
|----------------|---------------|--------------|----------------|
| 169 02 025.11V | <b>-2855F</b> | £663.60      | <b>£623.78</b> |

**Width 1750mm**

1x cupboard, 1x 125mm, 2x 175mm high drawers, 1x storage area and shelf.



| Product Number | Order Code    | List Price/1 | Offer Price/1  |
|----------------|---------------|--------------|----------------|
| 169 02 040.11V | <b>-2860K</b> | £611.63      | <b>£574.93</b> |

**Width 1750mm**

1x 125mm, 2x 175mm high drawers, 2x cupboard.



| Product Number | Order Code    | List Price/1 | Offer Price/1  |
|----------------|---------------|--------------|----------------|
| 169 02 042.11V | <b>-2861L</b> | £622.65      | <b>£585.29</b> |

**Width 1750mm**

3x 125mm, 6x 175mm high drawers.



| Product Number | Order Code    | List Price/1 | Offer Price/1  |
|----------------|---------------|--------------|----------------|
| 169 02 043.11V | <b>-2862M</b> | £862.05      | <b>£810.33</b> |

**Width 2000mm**

2x 125mm, 4x 175mm high drawers, 1x storage area with shelf.



| Product Number | Order Code    | List Price/1 | Offer Price/1  |
|----------------|---------------|--------------|----------------|
| 169 02 064.11V | <b>-2867S</b> | £754.43      | <b>£709.16</b> |

**Width 2000mm**

1x 125mm, 2x 175mm high drawers 2x cupboard.



| Product Number | Order Code    | List Price/1 | Offer Price/1  |
|----------------|---------------|--------------|----------------|
| 169 02 062.11V | <b>-2865Q</b> | £665.70      | <b>£625.76</b> |

**Width 2000mm**

3x 125mm, 6x 175mm high drawers.



| Product Number | Order Code    | List Price/1 | Offer Price/1  |
|----------------|---------------|--------------|----------------|
| 169 02 063.11V | <b>-2866R</b> | £904.05      | <b>£849.81</b> |

Workshop Equipment

**bott Heavy Duty Storage Benches**

Heavy duty benches with welded tubular steel frameworks and tough 40mm thick multiplex worktops. The integrated storage units feature lockable cupboards and 100kg capacity roller bearing slide drawers. All benches are supplied fully assembled ready for immediate use. Benches are 750mm deep and 840mm high.



Drawer dividers available - supplied separately

**Width 1500mm**

2x 500mm cupboard.



| Product Number | Order Code    | List Price/1 | Offer Price/1  |
|----------------|---------------|--------------|----------------|
| 410 02 022.11V | <b>-4701N</b> | £563.00      | <b>£529.22</b> |

**Width 1500mm**

4x 75mm drawers, 2x 350mm cupboard.



| Product Number | Order Code    | List Price/1 | Offer Price/1  |
|----------------|---------------|--------------|----------------|
| 410 02 147.11V | <b>-4721E</b> | £688.00      | <b>£646.72</b> |

**Width 1500mm**

4x 150mm drawers, 2x 200mm drawers.



| Product Number | Order Code    | List Price/1 | Offer Price/1  |
|----------------|---------------|--------------|----------------|
| 410 02 031.11V | <b>-4703Q</b> | £700.00      | <b>£658.00</b> |

**Width 1500mm**

1x 150mm drawer, 1x 350mm cupboard, 1x 500mm cupboard.



| Product Number | Order Code    | List Price/1 | Offer Price/1  |
|----------------|---------------|--------------|----------------|
| 410 02 146.11V | <b>-4720D</b> | £584.00      | <b>£548.96</b> |

**Width 1500mm**

1x 500mm cupboard.



| Product Number | Order Code    | List Price/1 | Offer Price/1  |
|----------------|---------------|--------------|----------------|
| 410 02 019.11V | <b>-4700M</b> | £525.00      | <b>£493.50</b> |

**Width 1500mm**

2x 150mm drawers, 1x 200mm drawer, 1x 500mm cupboard.



| Product Number | Order Code    | List Price/1 | Offer Price/1  |
|----------------|---------------|--------------|----------------|
| 410 02 025.11V | <b>-4702P</b> | £632.00      | <b>£594.08</b> |

**Width 2000mm**

2x 500mm cupboard.



| Product Number | Order Code    | List Price/1 | Offer Price/1  |
|----------------|---------------|--------------|----------------|
| 410 02 049.11V | <b>-4705S</b> | £729.00      | <b>£685.26</b> |

**Width 2000mm**

2x 350mm cupboard, 4x 150mm drawers, 1x 200mm drawer.



| Product Number | Order Code    | List Price/1 | Offer Price/1  |
|----------------|---------------|--------------|----------------|
| 410 02 064.11V | <b>-4709X</b> | £901.00      | <b>£846.94</b> |

**Width 2000mm**

2x 150mm drawers, 2x 350mm cupboard.



| Product Number | Order Code    | List Price/1 | Offer Price/1  |
|----------------|---------------|--------------|----------------|
| 410 02 052.11V | <b>-4706T</b> | £770.00      | <b>£723.80</b> |

**Width 2000mm**

3x 150mm drawers, 1x 200mm drawer, 1x 350mm cupboard.



| Product Number | Order Code    | List Price/1 | Offer Price/1  |
|----------------|---------------|--------------|----------------|
| 410 02 058.11V | <b>-4708W</b> | £819.00      | <b>£769.86</b> |

**Width 2000mm**

2x 150mm drawers, 1x 200mm drawer, 2x 500mm cupboard.



| Product Number | Order Code    | List Price/1 | Offer Price/1  |
|----------------|---------------|--------------|----------------|
| 410 02 055.11V | <b>-4707V</b> | £858.00      | <b>£806.52</b> |

**Width 2000mm**

4x 150mm drawers, 2x 200mm drawers.



| Product Number | Order Code    | List Price/1 | Offer Price/1  |
|----------------|---------------|--------------|----------------|
| 410 02 073.11V | <b>-4710Y</b> | £825.00      | <b>£775.50</b> |

**Height Extension Kit**

0 - 100mm, adjustable in 25mm.

| Product Number | Order Code    | List Price/1 | Offer Price/1 |
|----------------|---------------|--------------|---------------|
| 410 01 003.11V | <b>-4760M</b> | £31.00       | <b>£29.14</b> |



Workshop Equipment

All Prices Exclude V.A.T. © 2011

**Types of Worktops**

**Wisa** - Laminated ply core with mid grey polypropylene face. An easy clean top with good resistance to oil, grease, mild alkalis and weak acids.

**Mfc** - Particle board core with light grey laminate face. A light duty easy clean top suitable for assembly or office environments.

**Mpx** - Laminated beech ply. A tough, general duty top suitable for most applications.

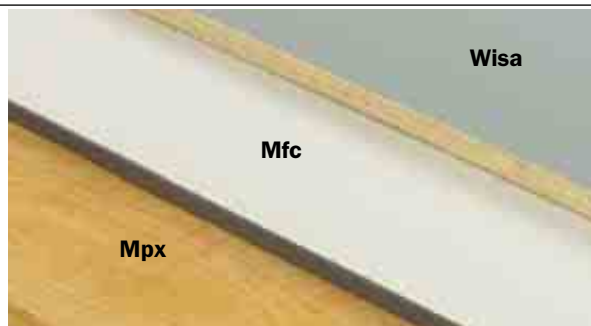

**Framework Bench**

A tough steel section framework, braced and finished in RAL7035 grey epoxy powder coat.

The 30mm worktop is available in multiplex or wisa. Full range of accessories available, including overhead kits and suspended cabinets. Flat packed for self assembly.

**Height:** 780mm.



**Workstand**

Space saving work units available as mobile or static. Base shelf can be inverted to create an anti-roll off upstand.

The 30mm worktop is available in multiplex or wisa. Available static or mobile.

**Dimensions:** 600 x 600 x 780mm high.



**Workstand**

| Product Number | Worktop Finish | Length (Metre) | Depth (mm) | Order Code BOT-405 | List Price/1 | Offer Price/1 |
|----------------|----------------|----------------|------------|--------------------|--------------|---------------|
| 169 01 012     | Mpx            | 1.5            | 600        | -2702T             | £215.25      | £202.34       |
| 169 01 016     |                | 1.5            | 800        | -2704W             | £257.25      | £241.81       |
| 169 01 020     |                | 2.0            | 600        | -2706Y             | £262.50      | £246.75       |
| 169 01 024     | Wisa           | 2.0            | 800        | -2709A             | £315.00      | £296.10       |
| 169 01 013     |                | 1.5            | 600        | -2703V             | £231.00      | £217.14       |
| 169 01 017     |                | 1.5            | 800        | -2705X             | £273.00      | £256.62       |
| 169 01 021     |                | 2.0            | 600        | -2707Z             | £283.50      | £266.49       |
| 169 01 025     |                | 2.0            | 800        | -2710B             | £336.00      | £315.84       |

| Product Number | Type   | Worktop Finish | Order Code BOT-405 | List Price/1 | Offer Price/1 |
|----------------|--------|----------------|--------------------|--------------|---------------|
| 169 01 000     | Static | Mpx            | -2700R             | £141.75      | £133.25       |
| 169 01 030     | Mobile |                | -2711C             | £173.25      | £162.85       |
| 169 01 001     | Static | Wisa           | -2701S             | £152.25      | £143.12       |
| 169 01 031     | Mobile |                | -2712D             | £183.75      | £172.72       |

**Cantilever bench**

Perfect for assembly applications, the cantilever frame comes complete with a 20mm worktop in either multiplex or mfc.

Full range of accessories available, including overhead kits and suspended cabinets. Flat packed for self assembly.

**Height:** 780mm.



| Product Number | Worktop Finish | Length (Metre) | Depth (mm) | Order Code BOT-405 | List Price/1 | Offer Price/1 |
|----------------|----------------|----------------|------------|--------------------|--------------|---------------|
| 169 01 308     | Mpx            | 1.5            | 600        | -2740H             | £270.00      | £253.80       |
| 169 01 312     |                | 1.5            | 800        | -2742K             | £320.00      | £300.80       |
| 169 01 316     |                | 2.0            | 600        | -2744M             | £320.00      | £300.80       |
| 169 01 320     |                | 2.0            | 800        | -2746P             | £370.00      | £347.80       |
| 169 01 309     | Mfc            | 1.5            | 600        | -2741J             | £270.00      | £253.80       |
| 169 01 313     |                | 1.5            | 800        | -2743L             | £320.00      | £300.80       |
| 169 01 317     |                | 2.0            | 600        | -2745N             | £320.00      | £300.80       |
| 169 01 321     |                | 2.0            | 800        | -2747Q             | £370.00      | £347.80       |



Model shown with optional suspended cabinet and rear overhead kit.

**bott** *Suspended Cabinets*

Cabinets fix directly into the bench framework, either left or right hand positions. In common with all accessories for this range, the cabinets can be fitted at a later date. All cabinets are 500mm wide x 550mm deep and centrally lockable.



**Height 600mm**  
2x 75mm drawer,  
3x 125mm drawer.



| Part Number    | Order Code <b>BOT-405</b> | List Price/1 | Offer Price/1  |
|----------------|---------------------------|--------------|----------------|
| 169 11 009.11V | <b>-2954E</b>             | £317.10      | <b>£298.07</b> |

**Height 250mm**  
1x 175mm drawer.



| Part Number    | Order Code <b>BOT-405</b> | List Price/1 | Offer Price/1  |
|----------------|---------------------------|--------------|----------------|
| 169 11 000.11V | <b>-2950A</b>             | £145.16      | <b>£136.45</b> |

**Height 600mm**  
1x 525mm  
cupboard.



| Part Number    | Order Code <b>BOT-405</b> | List Price/1 | Offer Price/1  |
|----------------|---------------------------|--------------|----------------|
| 169 11 005.11V | <b>-2952C</b>             | £149.36      | <b>£140.40</b> |

**Height 450mm**  
3x 125mm drawer.



| Part Number    | Order Code <b>BOT-405</b> | List Price/1 | Offer Price/1  |
|----------------|---------------------------|--------------|----------------|
| 169 11 003.11V | <b>-2951B</b>             | £234.68      | <b>£220.60</b> |

**Height 600mm**  
1x 125mm drawer  
1x 375mm cupboard.



| Part Number    | Order Code <b>BOT-405</b> | List Price/1 | Offer Price/1  |
|----------------|---------------------------|--------------|----------------|
| 169 11 006.11V | <b>-2953D</b>             | £197.93      | <b>£186.05</b> |

**Pedestal bench**

For optimum access and flexibility each pedestal bench leg is adjustable, giving height adjustment from 780 - 930mm. The 30mm worktop is available in multiplex or wisa.



**NEW**

| Product Number | Worktop Finish | Length (Metre) | Depth (mm) | Order Code <b>BOT-405</b> | List Price/1 | Offer Price/1  |
|----------------|----------------|----------------|------------|---------------------------|--------------|----------------|
| 169 01 604     | Mpx            | 1.5            | 600        | <b>-2760A</b>             | £199.50      | <b>£187.53</b> |
| 169 01 606     |                | 1.5            | 800        | <b>-2762C</b>             | £241.50      | <b>£227.01</b> |
| 169 01 608     |                | 2.0            | 600        | <b>-2764E</b>             | £231.00      | <b>£217.14</b> |
| 169 01 610     |                | 2.0            | 800        | <b>-2766G</b>             | £283.50      | <b>£266.49</b> |
| 169 01 605     | Wisa           | 1.5            | 600        | <b>-2761B</b>             | £215.25      | <b>£202.34</b> |
| 169 01 607     |                | 1.5            | 800        | <b>-2763D</b>             | £257.25      | <b>£241.81</b> |
| 169 01 609     |                | 2.0            | 600        | <b>-2765F</b>             | £252.00      | <b>£236.88</b> |
| 169 01 611     |                | 2.0            | 800        | <b>-2767H</b>             | £304.50      | <b>£286.23</b> |



**SELF ASSEMBLY Tools Required**

**Overhead kit**

The frame mounts securely to the bench leg of the framework or cantilever benches. Backpanel is available in three types: perforated, louvred or combi. 1115mm high (above worktop). Twin tube 240V light. 200mm deep shelf. 457mm high steel panel.



**To fit 1500mm benches**

| Product Number | Rear Frame supplied with    | Order Code <b>BOT-405</b> | List Price/1 | Offer Price/1  |
|----------------|-----------------------------|---------------------------|--------------|----------------|
| 16903000.16    | Perfo Panel                 | <b>-2900A</b>             | £70.09       | <b>£65.88</b>  |
| 16903001.16    | Louvre Panel                | <b>-2901B</b>             | £75.86       | <b>£71.31</b>  |
| 16903002.16    | Combi Panel                 | <b>-2902C</b>             | £72.98       | <b>£68.60</b>  |
| 16903003.16    | Shelf & Perfo Panel         | <b>-2903D</b>             | £112.35      | <b>£105.61</b> |
| 16903004.16    | Shelf & Louvre Panel        | <b>-2904E</b>             | £118.13      | <b>£111.04</b> |
| 16903005.16    | Shelf & Combi Panel         | <b>-2905F</b>             | £115.24      | <b>£108.33</b> |
| 16903006.16    | Light, Shelf & Perfo Panel  | <b>-2906G</b>             | £304.76      | <b>£286.47</b> |
| 16903007.16    | Light, Shelf & Louvre Panel | <b>-2907H</b>             | £310.54      | <b>£291.91</b> |
| 16903008.16    | Light, Shelf & Combi Panel  | <b>-2908J</b>             | £307.65      | <b>£289.19</b> |

**To fit 2000mm benches**

| Product Number | Rear Frame supplied with    | Order Code <b>BOT-405</b> | List Price/1 | Offer Price/1  |
|----------------|-----------------------------|---------------------------|--------------|----------------|
| 16903009.16    | Perfo Panel                 | <b>-2909K</b>             | £86.10       | <b>£80.93</b>  |
| 16903010.16    | Louvre Panel                | <b>-2910L</b>             | £91.88       | <b>£86.37</b>  |
| 16903011.16    | Combi Panel                 | <b>-2911M</b>             | £88.99       | <b>£83.65</b>  |
| 16903012.16    | Shelf & Perfo Panel         | <b>-2912N</b>             | £134.14      | <b>£126.09</b> |
| 16903013.16    | Shelf & Louvre Panel        | <b>-2913P</b>             | £139.91      | <b>£131.52</b> |
| 16903014.16    | Shelf & Combi Panel         | <b>-2914Q</b>             | £137.03      | <b>£128.81</b> |
| 16903015.16    | Light, Shelf & Perfo Panel  | <b>-2915R</b>             | £331.54      | <b>£311.65</b> |
| 16903016.16    | Light, Shelf & Louvre Panel | <b>-2916S</b>             | £337.31      | <b>£317.07</b> |
| 16903017.16    | Light, Shelf & Combi Panel  | <b>-2917T</b>             | £334.43      | <b>£314.36</b> |



**SELF ASSEMBLY Tools Required**

**CONTRACT PRICES AVAILABLE FOR VOLUME PURCHASES**

All Prices Exclude V.A.T. © 2011

Workshop Equipment

**MATLOCK** Framework Benches

Simple and economic solutions to the need of production assembly, maintenance and despatch personnel. 18mm FSC compliant chipboard working surface (210kg UDL). Shelves on workstations carry 150kg UDL. Robust uprights and light grey beam finish. Kits supplied with metal feet and full assembly instructions.

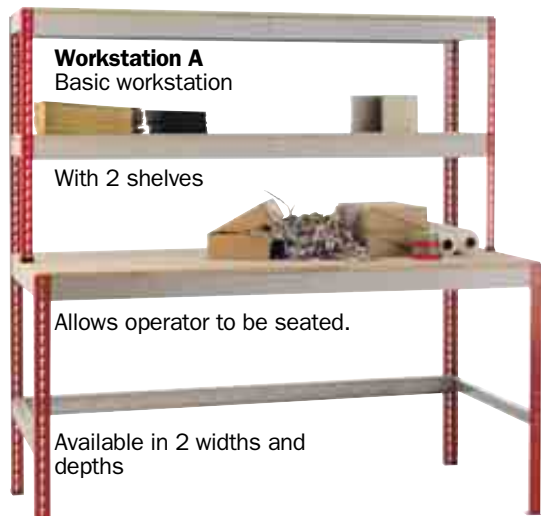

Shelf Capacity  
**150kg**

SELF ASSEMBLY  
Tools Required



| Dimensions<br>H x W x D (mm) | Blue/Grey<br>Order Code<br><b>MTL-405</b> | Red/Grey<br>Order Code<br><b>MTL-405</b> | Grey/Grey<br>Order Code<br><b>MTL-405</b> | List<br>Price/1 | Offer<br>Price/1 |
|------------------------------|---|--|---|-----------------|------------------|
| <b>Workstation A</b>         |   |  |   |                 |                  |
| 1830x1800x750                | <b>-3020K</b>                             | <b>-3030K</b>                            | <b>-3010K</b>                             | £226.58         | <b>£181.26</b>   |
| 1830x1800x900                | <b>-3060K</b>                             | <b>-3050K</b>                            | <b>-3040K</b>                             | £238.44         | <b>£190.75</b>   |
| 1830x2400x750                | <b>-3080K</b>                             | <b>-3090K</b>                            | <b>-3070K</b>                             | £250.85         | <b>£200.68</b>   |
| 1830x2400x900                | <b>-3120K</b>                             | <b>-3110K</b>                            | <b>-3100K</b>                             | £278.67         | <b>£222.94</b>   |

| Dimensions<br>H x W x D (mm) | Blue/Grey<br>Order Code<br><b>MTL-405</b> | Red/Grey<br>Order Code<br><b>MTL-405</b> | Grey/Grey<br>Order Code<br><b>MTL-405</b> | List<br>Price/1 | Offer<br>Price/1 |
|------------------------------|---|--|---|-----------------|------------------|
| <b>Workstation B</b>         |   |  |   |                 |                  |
| 1830x1800x750                | <b>-3220K</b>                             | <b>-3230K</b>                            | <b>-3210K</b>                             | £261.76         | <b>£209.41</b>   |
| 1830x1800x900                | <b>-3250K</b>                             | <b>-3260K</b>                            | <b>-3240K</b>                             | £277.79         | <b>£222.23</b>   |
| 1830x2400x750                | <b>-3280K</b>                             | <b>-3290K</b>                            | <b>-3270K</b>                             | £309.66         | <b>£247.73</b>   |
| 1830x2400x900                | <b>-3310K</b>                             | <b>-3320K</b>                            | <b>-3300K</b>                             | £328.10         | <b>£262.48</b>   |

**Add-on Bench**

With lower shelf. Provides additional working and storage space. Ideal for use with all benches and workstations.



| Dimensions<br>H x W x D (mm) | Blue/Grey<br>Order Code<br><b>MTL-405</b> | Red/Grey<br>Order Code<br><b>MTL-405</b> | Grey/Grey<br>Order Code<br><b>MTL-405</b> | List<br>Price/1 | Offer<br>Price/1 |
|------------------------------|---|--|---|-----------------|------------------|
| <b>Add-on Bench</b>          |   |  |   |                 |                  |
| 920x600x450                  | <b>-4020K</b>                             | <b>-4030K</b>                            | <b>-4010K</b>                             | £62.23          | <b>£49.78</b>    |
| 920x900x450                  | <b>-4050K</b>                             | <b>-4060K</b>                            | <b>-4040K</b>                             | £81.06          | <b>£64.85</b>    |
| 920x600x600                  | <b>-4080K</b>                             | <b>-4090K</b>                            | <b>-4070K</b>                             | £75.11          | <b>£60.09</b>    |
| 920x900x600                  | <b>-4110K</b>                             | <b>-4120K</b>                            | <b>-4100K</b>                             | £86.71          | <b>£69.37</b>    |

**Workstation C**

With louvre panel back and top shelf. Allows operator to be seated.



Available in 2 widths and depths

| Dimensions<br>H x W x D (mm) | Blue/Grey<br>Order Code<br><b>MTL-405</b> | Red/Grey<br>Order Code<br><b>MTL-405</b> | Grey/Grey<br>Order Code<br><b>MTL-405</b> | List<br>Price/1 | Offer<br>Price/1 |
|------------------------------|---|--|---|-----------------|------------------|
| <b>Workstation C</b>         |   |  |   |                 |                  |
| 1980x1500x750                | <b>-3420K</b>                             | <b>-3430K</b>                            | <b>-3410K</b>                             | £252.22         | <b>£201.78</b>   |



| Dimensions<br>H x W x D (mm) | Blue/Grey<br>Order Code<br><b>MTL-405</b> | Red/Grey<br>Order Code<br><b>MTL-405</b> | Grey/Grey<br>Order Code<br><b>MTL-405</b> | List<br>Price/1 | Offer<br>Price/1 |
|------------------------------|---|--|---|-----------------|------------------|
| <b>Bench A</b>               |   |  |   |                 |                  |
| 920x1800x750                 | <b>-3620K</b>                             | <b>-3630K</b>                            | <b>-3610K</b>                             | £114.83         | <b>£91.86</b>    |
| 920x2400x750                 | <b>-3650K</b>                             | <b>-3660K</b>                            | <b>-3640K</b>                             | £130.22         | <b>£104.18</b>   |
| 920x1800x900                 | <b>-3680K</b>                             | <b>-3690K</b>                            | <b>-3670K</b>                             | £126.69         | <b>£101.35</b>   |
| 920x2400x900                 | <b>-3710K</b>                             | <b>-3720K</b>                            | <b>-3700K</b>                             | £143.27         | <b>£114.62</b>   |



| Dimensions<br>H x W x D (mm) | Blue/Grey<br>Order Code<br><b>MTL-405</b> | Red/Grey<br>Order Code<br><b>MTL-405</b> | Grey/Grey<br>Order Code<br><b>MTL-405</b> | List<br>Price/1 | Offer<br>Price/1 |
|------------------------------|---|--|---|-----------------|------------------|
| <b>Bench B</b>               |   |  |   |                 |                  |
| 920x1800x750                 | <b>-3820K</b>                             | <b>-3830K</b>                            | <b>-3810K</b>                             | £150.01         | <b>£120.01</b>   |
| 920x2400x750                 | <b>-3850K</b>                             | <b>-3860K</b>                            | <b>-3840K</b>                             | £174.30         | <b>£139.44</b>   |
| 920x1800x900                 | <b>-3880K</b>                             | <b>-3890K</b>                            | <b>-3870K</b>                             | £166.02         | <b>£132.82</b>   |
| 920x2400x900                 | <b>-3910K</b>                             | <b>-3920K</b>                            | <b>-3900K</b>                             | £192.75         | <b>£154.20</b>   |

Workshop Equipment

**bott Workshop Computer Workstations**

**NEW**

650/1000mm wide x 550mm deep lockable cupboards with cable routing apertures.  
 Lockable slide out keyboard tray  
 Slide out shelf - ideal for printers (650mm wide model only)  
 Static shelf, adjustable on 25mm pitch with 50kg UDL  
 Lockable ventilated monitor housings  
 Sloping writing surface (1000mm wide models only).



**Enclosed Top**



| Product Number | Dimensions H x W x D (mm) | Order Code            | List Price/1 | Offer Price/1  |
|----------------|---------------------------|-----------------------|--------------|----------------|
| 169.123 05.11V | 1680 x 1000 x 550         | <b>BOT-405 -3060W</b> | £499.28      | <b>£469.32</b> |

**Optional File Holder**

File holding shelf to suit 1000mm wide model (above).



| Product Number | Order Code            | List Price/1 | Offer Price/1 |
|----------------|-----------------------|--------------|---------------|
| 169.123 06.16V | <b>BOT-405 -3060X</b> | £22.05       | <b>£20.73</b> |

**Open Top Workstation**



| Product Number | Dimensions H x W x D (mm) | Order Code            | List Price/1 | Offer Price/1  |
|----------------|---------------------------|-----------------------|--------------|----------------|
| 169.123 04.11V | 1130 x 1000 x 550         | <b>BOT-405 -3060V</b> | £371.70      | <b>£349.40</b> |

**Open Top Workstation**

Will suit TFT or CRT monitors.



| Product Number | Dimensions H x W x D (mm) | Order Code            | List Price/1 | Offer Price/1  |
|----------------|---------------------------|-----------------------|--------------|----------------|
| 169.123 07.11V | 1000 x 650 x 550          | <b>BOT-405 -3060Y</b> | £297.68      | <b>£279.82</b> |

**Enclosed Top Workstation**

TFT model for flat screen monitors.  
 CRT model for deeper monitors.



**TFT Model**



**CRT Model**



| Product Number | Type | Dimensions H x W x D (mm) | Order Code            | List Price/1 | Offer Price/1  |
|----------------|------|---------------------------|-----------------------|--------------|----------------|
| 169.123 09.11V | CRT  | 1550 x 650 x 550          | <b>BOT-405 -3060Z</b> | £373.80      | <b>£351.37</b> |
| 169.123 08.11V | TFT  | 1550 x 650 x 550          | <b>BOT-405 -3061A</b> | £396.38      | <b>£372.60</b> |

**Document Workstations**

Perfect for supervisory or general workshop use, these units combine secure storage with a sloping worksurface. All steel construction with epoxy powder coated grey/blue finish with reinforced, lockable doors, two adjustable shelves, two internal drawers and a sloping writing surface.

**Information Station**

Basic workstation complete with drywipe/magnetic rear surface.

**Tool Station**

As basic workstation, also complete with perforated backboard for toolholders.

**Quality Station**

Basic workstation complete with drywipe/magnetic rear surface and 10 file holder.

**Basic Workstation**

Basic workstation without back panel

**NEW**



**Basic Workstation**  
Without back panel



| Product Number | Dimensions H x W x D (mm) | Model               | Order Code            | List Price/1 | Offer Price/1  |
|----------------|---------------------------|---------------------|-----------------------|--------------|----------------|
| 169 123 01.11V | 2000 x 1000 x 550         | Information Station | <b>BOT-405 -3060R</b> | £423.68      | <b>£398.26</b> |
| 169 123 02.11V | 2000 x 1000 x 550         | Tool Station        | <b>-3060S</b>         | £428.93      | <b>£403.19</b> |
| 169 123 11.11V | 2000 x 1000 x 550         | Quality Station     | <b>-3061C</b>         | £464.63      | <b>£436.75</b> |
| 169 123 00.11V | 1000 x 1000 x 550         | Basic (no panel)    | <b>-3060Q</b>         | £367.50      | <b>£345.45</b> |

**CONTRACT PRICES AVAILABLE FOR VOLUME PURCHASES**

All Prices Exclude V.A.T. © 2011

**bot Drawer Cabinets**

Robust freestanding storage cabinets available in 2 widths. Can also be used as slide under pedestals for workbenches.

- Tough welded steel construction.
- 50kg load capacity per drawer.
- Fully lockable.
- Finished in epoxy powder coat gre/blue.
- All units are 550mm deep x 900mm high.



Drawer dividers are available for all models - call for details.



**Drawer Capacity**  
**50kg**  
Uniformly Distributed Load

**500mm wide Drawer Cabinet**

1x 700mm cupboard.



| Product Number | Order Code            | List Price/1 | Offer Price/1  |
|----------------|-----------------------|--------------|----------------|
| 169 11 211.11V | <b>BOT-405 -2970K</b> | £191.10      | <b>£179.63</b> |

**500mm wide Drawer Cabinet**

2x 75mm drawers, 1x 125mm drawer, 1x 525mm cupboard.



| Product Number | Order Code            | List Price/1 | Offer Price/1  |
|----------------|-----------------------|--------------|----------------|
| 169 11 212.11V | <b>BOT-405 -2971L</b> | £298.46      | <b>£280.55</b> |

**500mm wide Drawer Cabinet**

3x 75mm, 2x 125mm and 2x 175mm drawers.



| Product Number | Order Code            | List Price/1 | Offer Price/1  |
|----------------|-----------------------|--------------|----------------|
| 169 11 213.11V | <b>BOT-405 -2972M</b> | £430.24      | <b>£404.43</b> |

**500mm wide Drawer Cabinetd**

1x 75mm and 6x 125mm drawers.



| Product Number | Order Code            | List Price/1 | Offer Price/1  |
|----------------|-----------------------|--------------|----------------|
| 169 11 215.11V | <b>BOT-405 -2973N</b> | £429.19      | <b>£403.44</b> |

**500mm wide Drawer Cabinet**

1x 125mm and 4x 175mm drawers.



| Product Number | Order Code            | List Price/1 | Offer Price/1  |
|----------------|-----------------------|--------------|----------------|
| 169 11 216.11V | <b>BOT-405 -2974P</b> | £374.33      | <b>£351.87</b> |

**750mm wide Drawer Cabinet**

1x 825mm cupboard.



| Product Number | Order Code            | List Price/1 | Offer Price/1  |
|----------------|-----------------------|--------------|----------------|
| 169 11 223.11V | <b>BOT-405 -2975Q</b> | £237.04      | <b>£222.82</b> |

**750mm wide Drawer Cabinet**

2x 75mm, 1x 125mm drawers and 1x 525mm cupboard.



| Product Number | Order Code            | List Price/1 | Offer Price/1  |
|----------------|-----------------------|--------------|----------------|
| 169 11 224.11V | <b>BOT-405 -2976R</b> | £354.11      | <b>£332.86</b> |

**750mm wide Drawer Cabinet**

3x 75mm, 2x 125mm and 2x 175mm drawers.



| Product Number | Order Code            | List Price/1 | Offer Price/1  |
|----------------|-----------------------|--------------|----------------|
| 169 11 225.11V | <b>BOT-405 -2977S</b> | £494.03      | <b>£464.39</b> |

**750mm wide Drawer Cabinet**

1x 75mm and 6x 125mm drawers.



| Product Number | Order Code            | List Price/1 | Offer Price/1  |
|----------------|-----------------------|--------------|----------------|
| 169 11 227.11V | <b>BOT-405 -2978T</b> | £493.50      | <b>£463.89</b> |

**750mm wide Drawer Cabinet**

1x 125mm and 4x 175mm drawers.



| Product Number | Order Code            | List Price/1 | Offer Price/1  |
|----------------|-----------------------|--------------|----------------|
| 169 11 228.11V | <b>BOT-405 -2979V</b> | £428.93      | <b>£403.19</b> |

Workshop Equipment

**bott** Heavy Duty  
Drawer Cabinets

Create a clean, safe & well-organised storage space with heavy duty drawer cabinets. High capacity units in 5 different plan sizes. All cabinets are fully lockable and finished in epoxy powder coat RAL7035 grey with RAL5010 blue fronts. All drawers have 93% extension and 100kg capacity. Drawer dividers, steel slotted or plastic box kits supplied separately. See pages 712 - 713.

Drawer Capacity  
**100kg**  
Uniformly  
Distributed Load



**Size: 525 x 525 x 800mm (W x D x H)**



**Size: 800 x 750 (W x D)**

**1200mm Height**

**1600mm Height**



| Product Number | Fittings                                      | Order Code BOT-405 | List Price/1 | Offer Price/1  |
|----------------|---|--------------------|--------------|----------------|
| 40010023.11V   | 1x 100mm, 1x 175mm drawers, 1x 400mm cupboard | -4000A             | £358.00      | <b>£336.52</b> |
| 40010029.11V   | 4x 100mm, 2x 150mm drawers                    | -4001B             | £472.00      | <b>£443.68</b> |

| Product Number | Fittings  | Order Code BOT-405 | List Price/1 | Offer Price/1   |
|----------------|---|--------------------|--------------|-----------------|
| 40028037.11V   | 8x 100mm, 2x 150mm drawers                      | -4200M             | £1063.00     | <b>£999.22</b>  |
| 40028039.11V   | 2x 100mm, 4x 150mm, 2x 200mm, 1x 300mm, drawers | -4201N             | £1089.00     | <b>£1023.66</b> |

**Size: 650 x 650mm (W x D)**  
**900mm Height**

**1000mm Height**



| Product Number | Fittings                                      | Order Code BOT-405 | List Price/1 | Offer Price/1  |
|----------------|---|--------------------|--------------|----------------|
| 40019049.11V   | 3x 100mm, 2x 150mm, 1x 200mm drawers          | -4050K             | £569.00      | <b>£534.86</b> |
| 40019063.11V   | 2x 75mm, 2x 100mm, 1x 150mm, 2x 200mm drawers | -4052M             | £641.00      | <b>£602.54</b> |

**Size: 1050 x 750 x 1000mm (W x D x H)**



**Size: 800 x 650mm (W x D)**  
**900mm Height**

**1000mm Height**



| Product Number | Fittings                                      | Order Code BOT-405 | List Price/1 | Offer Price/1  |
|----------------|---|--------------------|--------------|----------------|
| 40020041.11V   | 5x 100mm, 2x 150mm drawers                    | -4100A             | £766.00      | <b>£720.04</b> |
| 40020053.11V   | 2x 75mm, 2x 100mm, 1x 150mm, 2x 200mm drawers | -4102C             | £786.00      | <b>£738.84</b> |

| Product Number | Fittings                                       | Order Code BOT-405 | List Price/1 | Offer Price/1   |
|----------------|--|--------------------|--------------|-----------------|
| 40029027.11V   | 9 x 100mm drawers                              | -4240W             | £1090.00     | <b>£1024.60</b> |
| 40029031.11V   | 2x 75mm, 1x 100mm, 3x 150mm, 2x 200mm, drawers | -4241X             | £1078.00     | <b>£1013.32</b> |

Workshop Equipment

**CONTRACT PRICES AVAILABLE FOR VOLUME PURCHASES**

All Prices Exclude V.A.T. © 2013

**Mobile Cabinets**

A range of engineers trolleys for storage on the move. A choice of metal top tray with three raised edges and inlaid mat or fitted with mpx worktop. Central locking and full depth push and pull handle. Each drawer has a safety trigger to prevent accidental opening. All units are 550mm deep and 925mm high. Available in 750 or 1000mm widths. Each unit has 125mm diameter castors (two with brake).

\*With fitted Multiplex (Mpx) worktop.



**750mm wide Mobile Cabinet**

4x 175mm drawers.

**NEW**



| Product Number  | Order Code <b>BOT-405</b> | List Price/1 | Offer Price/1  |
|-----------------|---------------------------|--------------|----------------|
| 169 13 006.11V  | <b>-3070A</b>             | £510.56      | <b>£479.93</b> |
| 169 13 007.11V* | <b>-3070B</b>             | £544.95      | <b>£512.25</b> |

**750mm Wide Mobile Cabinet**

2x 75mm, 3x 125mm and 1x 175mm drawers.



| Product Number  | Order Code <b>BOT-405</b> | List Price/1 | Offer Price/1  |
|-----------------|---------------------------|--------------|----------------|
| 169 13 012.11V  | <b>-3071B</b>             | £591.68      | <b>£556.18</b> |
| 169 13.013.11V* | <b>-3071C</b>             | £626.06      | <b>£588.50</b> |

**1000mm wide Mobile Cabinet**

4x 175mm drawers.



| Product Number  | Order Code <b>BOT-405</b> | List Price/1 | Offer Price/1  |
|-----------------|---------------------------|--------------|----------------|
| 169 13 024.11V  | <b>-3072C</b>             | £561.75      | <b>£528.04</b> |
| 169 13 025.11V* | <b>-3072D</b>             | £605.59      | <b>£569.25</b> |

**1000mm Wide Mobile Cabinet**

2x 75mm, 3x 125mm and 1x 175mm drawers.



| Product Number  | Order Code <b>BOT-405</b> | List Price/1 | Offer Price/1  |
|-----------------|---------------------------|--------------|----------------|
| 169 13 030.11V  | <b>-3073D</b>             | £654.94      | <b>£615.64</b> |
| 169 13 031.11V* | <b>-3073E</b>             | £698.78      | <b>£656.85</b> |

**Maintenance Trolleys**

Heavy gauge metal construction, manoeuvred on 125mm rubber castors, two of which swivel, two with brake. Central locking drawer stacks and individual trigger locks to prevent accidental opening. Metal top tray with three raised edges and inlaid mat. **Capacity:** 50kg UDL. All units are 550mm deep and 925mm high. \*With fitted Mpx worktop.



**1000mm Wide Maintenance Trolley**

2x 700mm cupboards.



| Product Number  | Order Code <b>BOT-405</b> | List Price/1 | Offer Price/1  |
|-----------------|---------------------------|--------------|----------------|
| 169 13 200.11V  | <b>-3080H</b>             | £377.00      | <b>£354.38</b> |
| 169 13 201.11V* | <b>-3080J</b>             | £418.75      | <b>£393.62</b> |

**1000mm Wide Maintenance Trolley**

4x 175mm drawers and 1x 700mm cupboard.



| Product Number  | Order Code <b>BOT-405</b> | List Price/1 | Offer Price/1  |
|-----------------|---------------------------|--------------|----------------|
| 169 13 220.11V  | <b>-3084M</b>             | £550.00      | <b>£517.00</b> |
| 169 13 221.11V* | <b>-3084N</b>             | £591.75      | <b>£556.25</b> |

**1000mm Wide Maintenance Trolley**

1x 75mm, 5x 125mm drawers and 1x 700mm cupboard.



| Product Number  | Order Code <b>BOT-405</b> | List Price/1 | Offer Price/1  |
|-----------------|---------------------------|--------------|----------------|
| 169 13 223.11V  | <b>-3085N</b>             | £615.75      | <b>£578.80</b> |
| 169 13 224.11V* | <b>-3085P</b>             | £657.50      | <b>£618.05</b> |

**1000mm Wide Maintenance Trolley**

8x 175mm drawers.



| Product Number  | Order Code <b>BOT-405</b> | List Price/1 | Offer Price/1  |
|-----------------|---------------------------|--------------|----------------|
| 169 13 240.11V  | <b>-3090T</b>             | £723.50      | <b>£680.09</b> |
| 169 13 241.11V* | <b>-3090V</b>             | £765.25      | <b>£719.34</b> |

Workshop Equipment

**bott** Heavy Duty Mobile Cabinets

Mobile cabinets for on-site storage. Centrally lockable and finished in epoxy powder coat RAL7035/RAL5010. Designed with safety in mind, features include: Push/pull handle. 125mm castor set 300kg capacity (two fixed, two swivel as standard and brake). Anti-roll off top tray and mat. Drawer blocking mechanism to prevent tipping. Safety trigger on each drawer to prevent accidental opening.  
**Capacity per drawer: 100kg.**



Drawer Capacity  
**100kg**  
Uniformly Distributed Load



Drawer dividers supplied separately. See pages 712 - 713

525 x 525mm (W x D)



-4500A



-4501B

650 x 650mm (W x D)



-4504E

525 x 525mm (W x D)



-4502C



-4503D

650 x 650mm (W x D)



-4505F



-4506G



-4507H

| Product Number | Dimensions W x D x H (mm) | Fittings                                      | Order Code BOT-405 | List Price/1 | Offer Price/1 |
|----------------|---------------------------|---|--------------------|--------------|---------------|
| 40402007.11V   | 525 x 525 x 780           | 2x 100mm, 1x 300mm drawers                    | -4500A             | £487.00      | £457.78       |
| 40402011.11V   | 525 x 525 x 880           | 2x 75mm, 2x 100mm, 1x 150mm drawers           | -4501B             | £571.00      | £536.74       |
| 40402013.11V   | 525 x 525 x 980           | 1x 100mm, 1x 200mm, 1x 300mm drawers          | -4502C             | £499.00      | £469.06       |
| 40402021.11V   | 525 x 525 x 980           | 4x 75mm, 1x 100mm, 2x 150mm drawers           | -4503D             | £683.00      | £642.02       |
| 40402023.11V   | 650 x 650 x 780           | 3x 100mm, 1x 200mm drawers                    | -4504E             | £610.00      | £573.40       |
| 40402027.11V   | 650 x 650 x 780           | 5x 100mm drawers                              | -4505F             | £661.00      | £621.34       |
| 40402031.11V   | 650 x 650 x 880           | 3x 100mm, 2x 150mm drawers                    | -4506G             | £668.00      | £627.92       |
| 40402035.11V   | 650 x 650 x 980           | 2x 75mm, 2x 100mm, 1x 150mm, 1x 200mm drawers | -4507H             | £740.00      | £695.60       |

**CONTRACT PRICES AVAILABLE FOR VOLUME PURCHASES**

All Prices Excl. V.A.T. © 2011

Workshop Equipment

**Drawer Divider Kits**

Customise your storage system with a high quality range of drawer division accessories. Steel variable divider kits manufactured from galvanised sheet steel or plastic box kits in RAL7011 impact resistant polystyrol.



**For drawers 525 x 525mm (W x D)  
5 Compartment**



| Product Number | Height (mm) | Order Code <b>BOT-405</b> | List Price/1 | Offer Price/1 |
|----------------|-------------|---------------------------|--------------|---------------|
| 43020229.51V   | 75          | <b>-4950H</b>             | £21.00       | <b>£19.74</b> |
| 43020232.51V   | 100/125     | <b>-4951J</b>             | £26.00       | <b>£24.44</b> |
| 43020235.51V   | 150+        | <b>-4952K</b>             | £22.00       | <b>£20.68</b> |

**9 Compartment**



| Product Number | Height (mm) | Order Code <b>BOT-405</b> | List Price/1 | Offer Price/1 |
|----------------|-------------|---------------------------|--------------|---------------|
| 43020230.51V   | 75          | <b>-4953L</b>             | £28.00       | <b>£26.32</b> |
| 43020233.51V   | 100/125     | <b>-4954M</b>             | £25.00       | <b>£23.50</b> |
| 43020236.51V   | 150+        | <b>-4955N</b>             | £32.00       | <b>£30.08</b> |

**24 Compartment**



| Product Number | Height (mm) | Order Code <b>BOT-405</b> | List Price/1 | Offer Price/1 |
|----------------|-------------|---------------------------|--------------|---------------|
| 43020106       | 75          | <b>-4900A</b>             | £25.20       | <b>£23.69</b> |
| 43020157       | 100+        | <b>-4912N</b>             | £29.40       | <b>£27.64</b> |

**For drawers 650 x 650mm (W x D)  
8 Compartment**



| Product Number | Height (mm) | Order Code <b>BOT-405</b> | List Price/1 | Offer Price/1 |
|----------------|-------------|---------------------------|--------------|---------------|
| 43020265.51V   | 75          | <b>-4956P</b>             | £31.00       | <b>£29.14</b> |
| 43020268.51V   | 100/125     | <b>-4958R</b>             | £32.00       | <b>£30.08</b> |
| 43020271.51V   | 150+        | <b>-4960T</b>             | £38.00       | <b>£35.72</b> |

**9 Compartment**



| Product Number | Height (mm) | Order Code <b>BOT-405</b> | List Price/1 | Offer Price/1 |
|----------------|-------------|---------------------------|--------------|---------------|
| 43020266.51V   | 75          | <b>-4957Q</b>             | £33.00       | <b>£31.02</b> |
| 43020269.51V   | 100/125     | <b>-4959S</b>             | £33.00       | <b>£31.02</b> |
| 43020272.51V   | 150+        | <b>-4961V</b>             | £40.00       | <b>£37.60</b> |

**21 Compartment**



| Product Number | Height (mm) | Order Code <b>BOT-405</b> | List Price/1 | Offer Price/1 |
|----------------|-------------|---------------------------|--------------|---------------|
| 43020118       | 75          | <b>-4902C</b>             | £28.35       | <b>£26.65</b> |
| 43020169       | 100+        | <b>-4914Q</b>             | £33.60       | <b>£31.58</b> |

**For drawers 800 x 650mm (W x D)  
8 Compartment**



| Product Number | Height (mm) | Order Code <b>BOT-405</b> | List Price/1 | Offer Price/1 |
|----------------|-------------|---------------------------|--------------|---------------|
| 43020301.51V   | 75          | <b>-4965A</b>             | £34.00       | <b>£31.96</b> |
| 43020304.51V   | 100/125     | <b>-4967C</b>             | £36.00       | <b>£33.84</b> |
| 43020307.51V   | 150+        | <b>-4969E</b>             | £42.00       | <b>£39.48</b> |

**12 Compartment**



| Product Number | Height (mm) | Order Code <b>BOT-405</b> | List Price/1 | Offer Price/1 |
|----------------|-------------|---------------------------|--------------|---------------|
| 43020302.51V   | 75          | <b>-4966B</b>             | £45.00       | <b>£42.30</b> |
| 43020305.51V   | 100/125     | <b>-4968D</b>             | £46.00       | <b>£43.24</b> |
| 43020308.51V   | 150+        | <b>-4970F</b>             | £55.00       | <b>£51.70</b> |

**27 Compartment**



| Product Number | Height (mm) | Order Code <b>BOT-405</b> | List Price/1 | Offer Price/1 |
|----------------|-------------|---------------------------|--------------|---------------|
| 43020127       | 75          | <b>-4904E</b>             | £33.60       | <b>£31.58</b> |
| 43020178       | 100+        | <b>-4916S</b>             | £40.95       | <b>£38.49</b> |

Workshop Equipment

**bott** *Drawer Divider Kits* continued

For drawers 800 x 750mm (W x D)  
9 Compartment



| Product Number | Height (mm) | Order Code <b>BOT-405</b> | List Price/1 | Offer Price/1 |
|----------------|-------------|---------------------------|--------------|---------------|
| 43020313.51V   | 75          | -4971G                    | £37.00       | <b>£34.78</b> |
| 43020316.51V   | 100/125     | -4973J                    | £40.00       | <b>£37.60</b> |
| 43020319.51V   | 150+        | -4975L                    | £46.00       | <b>£43.24</b> |

For drawers 1050 x 750mm (W x D)  
12 Compartment



| Product Number | Height (mm) | Order Code <b>BOT-405</b> | List Price/1 | Offer Price/1 |
|----------------|-------------|---------------------------|--------------|---------------|
| 43020349.51V   | 75          | -4984W                    | £39.00       | <b>£36.66</b> |
| 43020352.51V   | 100/125     | -4986Y                    | £43.00       | <b>£40.42</b> |
| 43020355.51V   | 150+        | -4989A                    | £51.00       | <b>£47.94</b> |

For drawers 800 x 750mm (W x D)  
13 Compartment



| Product Number | Height (mm) | Order Code <b>BOT-405</b> | List Price/1 | Offer Price/1 |
|----------------|-------------|---------------------------|--------------|---------------|
| 43020314.51V   | 75          | -4972H                    | £52.00       | <b>£48.88</b> |
| 43020317.51V   | 100/125     | -4974K                    | £51.00       | <b>£47.94</b> |
| 43020320.51V   | 150+        | -4976M                    | £62.00       | <b>£58.28</b> |

For drawers 1050 x 750mm (W x D)  
18 Compartment



| Product Number | Height (mm) | Order Code <b>BOT-405</b> | List Price/1 | Offer Price/1 |
|----------------|-------------|---------------------------|--------------|---------------|
| 43020350.51V   | 75          | -4985X                    | £50.00       | <b>£47.00</b> |
| 43020353.51V   | 100/125     | -4987Z                    | £55.00       | <b>£51.70</b> |
| 43020356.51V   | 150+        | -4990B                    | £65.00       | <b>£61.10</b> |

For drawers 800 x 750mm (W x D)  
41 Compartment



| Product Number | Height (mm) | Order Code <b>BOT-405</b> | List Price/1 | Offer Price/1 |
|----------------|-------------|---------------------------|--------------|---------------|
| 43020130       | 75          | -4906G                    | £47.25       | <b>£44.41</b> |
| 43020181       | 100+        | -4918V                    | £55.65       | <b>£52.31</b> |

For drawers 1050 x 750mm (W x D)  
64 Compartment



| Product Number | Height (mm) | Order Code <b>BOT-405</b> | List Price/1 | Offer Price/1 |
|----------------|-------------|---------------------------|--------------|---------------|
| 43020139       | 75          | -4908J                    | £66.15       | <b>£62.18</b> |
| 43020190       | 100+        | -4924A                    | £79.80       | <b>£75.01</b> |

**Tilt Boxes**

The tilt box system is based on a range of clip together plastic housings, which contain transparent small parts boxes with a forward tilt action to give access. Tilt box storage is useful in all environments including office, retail and manufacturing providing highly visible, dense and dust protective storage for most small components. Choose the individual models, or the mixed kit of the 9/6/5/4 compartment versions. All models are 600mm wide.



-1031L  
3 box unit



-1032M  
Mixed Kit



-1033N  
Bench Stand Kit



-1881Y  
Madia Free Standing Rack  
(modules not included)

**Bench Stands & Bench Kits**

Tilt box units can be located within this bench top stand which will accept any combination of tilt boxes within the usable height of 500mm. Supplied in red only. The most popular tilt box combination is shown.

Dimensions (W x D x H): 610 x 150 x 500mm.

**Individual Units**

| Product Number | Overall size D x H (mm) | Boxes | Compartment Size W x D x H (mm) | Pack Qty | Order Code <b>BOT-405</b> | List Price/1 | Offer Price/1 |
|----------------|-------------------------|-------|---------------------------------|----------|---------------------------|--------------|---------------|
| 02513043       | 51 x 77                 | 9     | 60 x 47 x 66                    | 3        | -1034P                    | £26.16       | <b>£24.59</b> |
| 02513044       | 96 x 112                | 6     | 88 x 65 x 98                    | 3        | -1035Q                    | £33.25       | <b>£31.25</b> |
| 02513045       | 170 x 206               | 5     | 113 x 104 x 151                 | 2        | -1036R                    | £34.88       | <b>£32.79</b> |
| 02513004       | 200 x 240               | 4     | 142 x 133 x 193                 | 1        | -1030K                    | £26.16       | <b>£24.59</b> |
| 02513005       | 200 x 240               | 3     | 191 x 154 x 225                 | 1        | -1031L                    | £29.98       | <b>£28.18</b> |

**Bench Stands & Kits**

| Product Number | Description     | Tilt Box Modules              | Order Code <b>BOT-405</b> | List Price/1 | Offer Price/1 |
|----------------|-----------------|-------------------------------|---------------------------|--------------|---------------|
| 02513026       | Mixed Kit       | 1 ea. x 9, 6, 5, 4 comp.      | -1032M                    | £63.22       | <b>£59.43</b> |
| 11903088.04    | Bench Stand     | -                             | -1880X                    | £32.16       | <b>£30.23</b> |
| 02513027.04    | Bench Stand Kit | 5x 9 box, 1x 6 box + 1x stand | -1033N                    | £86.66       | <b>£81.46</b> |

**Madia Free Standing Rack**

| Product Number | Description        | Tilt Box Modules       | Order Code <b>BOT-405</b> | List Price/1 | Offer Price/1 |
|----------------|--------------------|------------------------|---------------------------|--------------|---------------|
| 11903090       | Free Standing Rack | rack only - no modules | -1881Y                    | £68.30       | <b>£64.20</b> |

**CONTRACT PRICES AVAILABLE FOR VOLUME PURCHASES**

All Prices Exclude V.A.T. © 2011

**Tool Blocks**

Steel bodies with resilient plastic inserts to store and protect spindle nose tooling. Free-standing or for use in conjunction with trolleys and racks.



10-14 Days

| Product Number | Taper Type | Tool Block Capacity | Order Code BOT-406 | List Price/1 | Offer Price/1 |
|----------------|------------|---------------------|--------------------|--------------|---------------|
| 150 02 057.12  | ISO/BT30   | 4 Pot               | -2552R             | £27.25       | £25.61        |
| 150 02 059.12  | ISO/BT40   | 3 Pot               | -2553S             | £27.25       | £25.61        |
| 150 02 061.12  | ISO/BT50   | 2 Pot               | -2554T             | £27.25       | £25.61        |
| 150 02 062.12  | VDI 30     | 3 Pot               | -2555V             | £27.25       | £25.61        |
| 150 02 063.12  | VDI 40     | 3 Pot               | -2556W             | £27.25       | £25.61        |

**Standard Tool Storage Trolleys**

Compact trolley for use with up to six tool carriers. Two swivel castors with full locking brake and two fixed castors. Top tray is lined with rubber mat for additional storage.

Dimensions (H x W x D): 1020 x 650 x 710mm.



Tool carriers are not included

10-14 Days

| Product Number | Carrier Block Capacity | Weight each | Order Code BOT-406 | List Price/1 | Offer Price/1 |
|----------------|------------------------|-------------|--------------------|--------------|---------------|
| 104 01 030.16  | 6                      | 46kg        | -1811K             | £336.81      | £316.60       |

**Transport Trolley**

Multi position for use with CWT tool carriers. Tool carriers are inserted into the trolleys using the suspension brackets. Two swivel castors with full locking brake and two fixed castors. For up to 10-12 tool carriers. Optional end shelf with rubber mat. Enhanced safety as the tooling can be stored within the confines of the trolley.

Note:

To store each carrier block, a pair of carrier suspension brackets must be ordered.

The model shown also features an optional end shelf.

Dimensions (W x D x H): 980 x 600 x 985mm.



Tool carriers are not included

10-14 Days

| Product Number | Description                 | Order Code BOT-406 | List Price/1 | Offer Price/1 |
|----------------|-----------------------------|--------------------|--------------|---------------|
| 104 01 029.16  | Multi-position trolley      | -1810J             | £372.78      | £350.41       |
| 121 02 084.16  | Optional end shelf          | -1900A             | £47.96       | £45.08        |
| 150 03 011.16  | Carrier mntg. brackets (Pr) | -2570M             | £7.63        | £7.17         |

**Heavy Duty CNC Tool Storage Trolleys**

This heavy duty trolley allows tools to be transported safely and effectively throughout a workshop environment. The trolley will accept up to 24 tool blocks, dependent upon tooling size.

Dimensions (H x W x D): 1150 x 1115 x 600mm.



Tool blocks supplied separately

10-14 Days

| Product Number | Tool Block Capacity | Weight each | Order Code BOT-406 | List Price/1 | Offer Price/1 |
|----------------|---------------------|-------------|--------------------|--------------|---------------|
| 104 03 013.03  | 24                  | 62kg        | -1819Q             | £488.32      | £459.02       |

**CNC Tool-Rack Storage System**

Available in single and double sided units. A flexible design which allows the free standing starter units to have add-on bays on the side to create longer runs wherever necessary.



All units must be firmly fixed to the floor.

**For Spindle Nose Tooling**

See Group **144**

10-14 Days

Tool blocks supplied separately

| Product Number  | Rack Type          | Weight each | Order Code BOT-406 | List Price/1 | Offer Price/1 |
|---|--------------------|-------------|--------------------|--------------|---------------|
| <b>Single Sided - Dimensions (H x W x D): 1835 x 1015 x 555mm</b> |                    |             |                    |              |               |
| 121 02 092.03   | Starter + 4 panels | 47kg        | -1902C             | £274.68      | £258.20       |
| 121 02 093.03   | Add On + 4 panels  |             | -1903D             | £223.45      | £210.04       |
| <b>Double Sided - Dimensions (H x W x D): 1835 x 1015 x 905mm</b> |                    |             |                    |              |               |
| 121 02 094.03   | Starter + 8 panels | 72kg        | -1904E             | £454.53      | £427.26       |
| 121 02 095.03   | Add On + 8 panels  |             | -1905F             | £361.88      | £340.17       |

**Louvre Wall Panels**

Symmetrically louvred sheet steel panels, to accept storage bins and tool carrier blocks. Fixing points allow easy wall mounting. Double folds aid rigidity - horizontal panels have reinforcing backstrips.



10-14 Days

| Product Number | Size W x H (mm) | Order Code BOT-406 | List Price/1 | Offer Price/1 |
|----------------|-----------------|--------------------|--------------|---------------|
| 140 25 137.11  | 495 x 457       | -2350J             | £14.26       | £13.40        |
| 140 25 139.11  | 990 x 457       | -2351K             | £26.02       | £24.46        |
| 140 25 140.11  | 1486 x 457      | -2352L             | £37.72       | £35.46        |
| 140 25 141.11  | 1981 x 457      | -2353M             | £62.87       | £59.10        |

**Drawer Inserts**

Suitable for use with all drawer cabinets shown on page ???.

10-14 Days

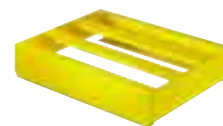

| Product Number                     | Drawer Size W x D (mm) | Useable Size (mm) | Order Code BOT-406 | List Price/1 | Offer Price/1 |
|------------------------------------|------------------------|-------------------|--------------------|--------------|---------------|
| <b>To Suit Drawer Height 125mm</b> |                        |                   |                    |              |               |
| 430 13 001.12V                     | 525 x 525              | 2 x 375           | -4870E             | £47.00       | £44.18        |
| 430 13 013.12V                     | 650 x 650              | 3 x 500           | -4873H             | £55.00       | £51.70        |
| 430 13 115.12V                     | 800 x 525              | 2 x 650           | -4890X             | £55.00       | £51.70        |
| 430 13 015.12V                     | 800 x 650              | 3 x 650           | -4875K             | £60.00       | £56.40        |
| 430 13 025.12V                     | 800 x 750              | 4 x 650           | -4878N             | £66.00       | £62.04        |
| 430 13 027.12V                     | 1050 x 750             | 4 x 900           | -4850A             | £78.00       | £73.32        |
| <b>To Suit Drawer Height 175mm</b> |                        |                   |                    |              |               |
| 430 13 002.12V                     | 525 x 525              | 2 x 375           | -4871F             | £50.00       | £47.00        |
| 430 13 014.12V                     | 650 x 650              | 3 x 500           | -4874J             | £58.00       | £54.52        |
| 430 13 006.12V                     | 800 x 525              | 2 x 650           | -4872G             | £59.00       | £55.46        |
| 430 13 016.12V                     | 800 x 650              | 3 x 650           | -4876L             | £64.00       | £60.16        |
| 430 13 026.12V                     | 800 x 750              | 4 x 650           | -4879P             | £71.00       | £66.74        |
| 430 13 028.12V                     | 1050 x 750             | 4 x 900           | -4880Q             | £82.00       | £77.08        |

**CNC Tool Inserts**

For use in conjunction with empty drawer inserts above.



10-14 Days

| Product Number | Taper         | Width (mm) | Order Code BOT-406 | List Price/1 | Offer Price/1 |
|----------------|---------------|------------|--------------------|--------------|---------------|
| 150 02 042     | HSK A40/B50   | 50         | -2540D             | £2.44        | £2.29         |
| 150 02 043     | HSK A32/B40   | 50         | -2541E             | £2.44        | £2.29         |
| 150 02 044     | VDI 30        | 75         | -2542F             | £3.24        | £3.05         |
| 150 02 045     | VDI 40        | 75         | -2543G             | £3.24        | £3.05         |
| 150 02 047     | ISO 40/BT40   | 75         | -2544H             | £3.24        | £3.05         |
| 150 02 048     | ISO 45/MT5    | 75         | -2545I             | £3.24        | £3.05         |
| 150 02 049     | HSK A50/B63   | 75         | -2546K             | £3.24        | £3.05         |
| 150 02 050     | HSK A63/B80   | 75         | -2547L             | £3.24        | £3.05         |
| 150 02 051     | VDI 50        | 100        | -2548M             | £4.05        | £3.81         |
| 150 02 053     | ISO 50        | 100        | -2549N             | £4.05        | £3.81         |
| 150 02 054     | HSK A80/B100  | 100        | -2550P             | £4.05        | £3.81         |
| 150 02 055     | HSK A100/B125 | 100        | -2551Q             | £4.05        | £3.81         |

**bott** Tool Carriers

Tool carrier blocks offer a new, flexible method of storing CNC tooling. Individual tool pots simply clip into the carrier block. Specify the type of tooling and then add the required amount of storage pots to the carrier block. Tool carrier blocks may be used in conjunction with trolleys, cupboards or freestanding on a bench top. Supplied in yellow RAL1023 only.

**Tool carrier block dimensions (W x D x H):** 590 x 124 x 110mm.



Tool blocks can mount directly into 750mm wide drawers.

10-14 Days

| Product Number | Taper Type    | Max Block | Order Code BOT-406 | List Price/1 | Offer Price/1 |
|----------------|---------------|-----------|--------------------|--------------|---------------|
| 150 01 012.12  | ISO30         | 10        | -2502C             | £50.14       | £47.13        |
| 150 01 013.12  | ISO35         | 6         | -2503D             | £50.14       | £47.13        |
| 150 01 014.12  | ISO40         | 6         | -2504E             | £50.14       | £47.13        |
| 150 01 015.12  | ISO45         | 6         | -2505F             | £50.14       | £47.13        |
| 150 01 016.12  | ISO50         | 5         | -2506G             | £50.14       | £47.13        |
| 150 01 017.12  | VDI30         | 6         | -2507H             | £50.14       | £47.13        |
| 150 01 018.12  | VDI40         | 6         | -2508J             | £50.14       | £47.13        |
| 150 01 019.12  | VDI50         | 5         | -2509K             | £50.14       | £47.13        |
| 150 01 020.12  | VDI60         | 5         | -2510L             | £50.14       | £47.13        |
| 150 01 021.12  | HSK A32/B40   | 10        | -2511M             | £50.14       | £47.13        |
| 150 01 022.12  | HSK A40/B50   | 10        | -2512N             | £50.14       | £47.13        |
| 150 01 023.12  | HSK A50/B63   | 6         | -2513P             | £50.14       | £47.13        |
| 150 01 024.12  | HSK A63/B80   | 6         | -2514Q             | £50.14       | £47.13        |
| 150 01 025.12  | HSK A80/B100  | 5         | -2515R             | £50.14       | £47.13        |
| 150 01 026.12  | HSK A100/B125 | 5         | -2516S             | £50.14       | £47.13        |
| 150 01 030.12  | Capto 3       | 10        | -2517T             | £50.14       | £47.13        |
| 150 01 031.12  | Capto 4       | 10        | -2518V             | £50.14       | £47.13        |
| 150 01 032.12  | Capto 5       | 6         | -2519W             | £50.14       | £47.13        |
| 150 01 033.12  | Capto 6       | 6         | -2520X             | £50.14       | £47.13        |

**Bench Stand**

The bench stand is a freestanding unit which can accept up to three of the tool carriers shown above. Finished in epoxy powder coated grey (RAL7035).

10-14 Days

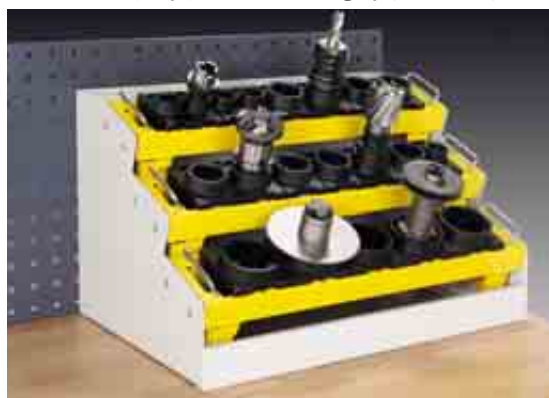

Tool carriers not included

| Product Number | Dimensions (mm) W x D x H | Weight each | Order Code BOT-406 | List Price/1 | Offer Price/1 |
|----------------|---------------------------|-------------|--------------------|--------------|---------------|
| 150 01 003     | 600 x 450 x 375           | 5kg         | -2500A             | £119.75      | £112.56       |

**Taper Socket Cleaners**

Will remove large residual particles of grease, dust and swarf from internal sockets. Maintains precision and prolongs life of tool holders.



| Taper Type     | Order Code KEN-406 | List Price/1 | Offer Price/1 |
|----------------|--------------------|--------------|---------------|
| Morse Taper 1  | -8010K             | £21.65       | £19.70        |
| Morse Taper 2  | -8020K             | £21.65       | £19.70        |
| Morse Taper 3  | -8030K             | £21.65       | £19.70        |
| Morse Taper 4  | -8040K             | £21.65       | £19.70        |
| Morse Taper 5  | -8050K             | £21.65       | £19.70        |
| ISO/BT20 Taper | -8140K             | £21.65       | £19.70        |
| ISO/BT30 Taper | -8160K             | £21.65       | £19.70        |
| ISO/BT40 Taper | -8180K             | £32.45       | £29.53        |
| ISO/BT50 Taper | -8200K             | £32.45       | £29.53        |

**CNC Storage Cupboard**

Tools may be stored in a tidy, dust-free environment within this cupboard. A lockable door secures the contents and has perforated inner panels for tool hooks. Supplied empty, there are a variety of different storage options for within the cupboard including storage drawers and extending shelves.

**Dimensions (W x D x H):** 800 x 525 x 2000mm.

10-14 Days



Workshop Equipment

**Internal Fittings**

**CNC Tool Storage Shelf** for carriers - extendable. Holds up to 80kg will require 3 tool carriers.



**CNC Tool Storage Shelf** - extendable. Holds up to 80kg, tool inserts fit directly onto shelf (requires tool inserts see page 726). The useable space for tool inserts is 3 x 625mm for example, when using 50mm tool inserts, the maximum amount that would fit in 3 rows is 36.



**CNC Tool Storage Drawer** - use empty or with drawer insert 430 13 006.12V and tool inserts from page ???.



10 - 14 Days

| Product Number                                 | Description                   | Order Code BOT-406 | List Price/1 | Offer Price/1 |
|--|-------------------------------|--------------------|--------------|---------------|
| 400 12 059.11V                                 | Cupboard with perfo doors     | -4020F             | £470.00      | £441.80       |
| <b>Internal Fittings (Supplied Separately)</b> |                               |                    |              |               |
| 405 23 001.12V                                 | Carrier storage shelf (empty) | -4690L             | £118.00      | £110.92       |
| 405 23 002.12V                                 | Insert storage shelf (empty)  | -4691M             | £108.00      | £101.52       |
| 405 22 015.16M                                 | Tool storage drawer (empty)   | -4590P             | £56.00       | £52.64        |

**CONTRACT PRICES AVAILABLE FOR VOLUME PURCHASES**

All Prices Exclude V.A.T. © 2011

**Precision Ground Flat Stock**

A medium alloyed oil hardening steel with excellent cutting force and toughness, excellent dimensional stability. Supplied in the annealed condition, precision tolerances provides toolmakers with a decarburization free surface, plus a high wear resistance after heat treatment, ideal for a multitude of applications: dies, press tools, punches, gauges, cams machine knives and marking devices. Line ground all edges up to and including 2"/50mm wide in the thicknesses up to and including 1/4"/6mm. All other dimensions are rotary ground on edges. All edges and ends are deburred thicknesses of 3/8"/10mm and above will be supplied with sawn ends, thinner sections are supplied with sheared ends. Each piece is individually straightened with a flatness aim of 0.127/500mm (0.005"/18")

**A.I.S.I. 01 GFS - Chemical Analysis**

|                |              |
|----------------|--------------|
| Carbon (C)     | 0.90 - 1.00% |
| Silicon (Si)   | 0.40%        |
| Manganese (Mn) | 1.00 - 1.20% |
| Chromium (Cr)  | 0.50 - 0.70% |
| Tungsten (W)   | 0.50 - 0.70% |
| Vanadium (Va)  | 0.05 - 0.25% |

Hardness as supplied: 229 Brinell max  
Tensile Strength: 45 Tons/sq. in.

Equivalent specifications:

**AISI:** O1,  
**Werk. No.:** 1.2510,  
**AFNOR:** 95 MCWV5,  
**British Spec.:** BS4659 B01

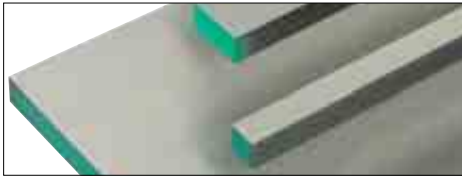

**Metric Sizes:**

**Tolerances:** Thickness +/-0.05mm/-nil,  
Width +0.02mm/-nil, Length Nominal.

| Size            | Order Code CTL-413 | List Price/1 | Offer Price/1 |
|-----------------|--------------------|--------------|---------------|
| 1 x 10 x 500    | -3100A             | £4.31        | £3.28         |
| 1 x 15 x 500    | -3101B             | £4.43        | £3.37         |
| 1 x 20 x 500    | -3102C             | £4.95        | £3.76         |
| 1 x 25 x 500    | -3103D             | £5.45        | £4.14         |
| 1 x 30 x 500    | -3104E             | £5.93        | £4.51         |
| 1 x 40 x 500    | -3105F             | £6.38        | £4.85         |
| 1 x 50 x 500    | -3106G             | £7.33        | £5.57         |
| 1 x 60 x 500    | -3107H             | £8.81        | £6.70         |
| 1 x 75 x 500    | -3108J             | £9.88        | £7.51         |
| 1 x 80 x 500    | -3109K             | £15.27       | £11.61        |
| 1 x 100 x 500   | -3110L             | £12.71       | £9.66         |
| 1 x 125 x 500   | -3111M             | £15.16       | £11.52        |
| 1 x 150 x 500   | -3112N             | £16.61       | £12.62        |
| 1 x 200 x 500   | -3113P             | £21.99       | £16.71        |
| 1 x 250 x 500   | -3114Q             | £27.11       | £20.60        |
| 1 x 300 x 500   | -3115R             | £32.68       | £24.84        |
| 1.5 x 10 x 500  | -3200A             | £4.69        | £3.56         |
| 1.5 x 15 x 500  | -3201B             | £4.76        | £3.62         |
| 1.5 x 20 x 500  | -3202C             | £5.28        | £4.01         |
| 1.5 x 25 x 500  | -3203D             | £5.81        | £4.42         |
| 1.5 x 30 x 500  | -3204E             | £6.14        | £4.67         |
| 1.5 x 40 x 500  | -3205F             | £7.14        | £5.43         |
| 1.5 x 50 x 500  | -3206G             | £8.19        | £6.22         |
| 1.5 x 60 x 500  | -3207H             | £9.97        | £7.66         |
| 1.5 x 75 x 500  | -3208J             | £10.45       | £7.94         |
| 1.5 x 80 x 500  | -3209K             | £11.80       | £8.97         |
| 1.5 x 100 x 500 | -3210L             | £18.11       | £13.76        |
| 1.5 x 125 x 500 | -3211M             | £15.68       | £11.92        |
| 1.5 x 150 x 500 | -3212N             | £20.50       | £15.58        |
| 1.5 x 200 x 500 | -3213P             | £26.04       | £19.79        |
| 1.5 x 250 x 500 | -3214Q             | £28.37       | £21.56        |
| 1.5 x 300 x 500 | -3215R             | £34.61       | £26.30        |
| 2 x 10 x 500    | -3300A             | £4.55        | £3.46         |
| 2 x 15 x 500    | -3301B             | £4.83        | £3.67         |
| 2 x 20 x 500    | -3302C             | £5.47        | £4.16         |
| 2 x 25 x 500    | -3303D             | £5.88        | £4.47         |
| 2 x 25 x 1000   | -3303Q             | £11.78       | £8.95         |
| 2 x 30 x 500    | -3304E             | £6.33        | £4.81         |
| 2 x 40 x 500    | -3305F             | £6.95        | £5.28         |
| 2 x 50 x 500    | -3306G             | £8.04        | £6.11         |
| 2 x 60 x 500    | -3307H             | £9.57        | £7.27         |
| 2 x 75 x 500    | -3308J             | £10.61       | £8.06         |
| 2 x 80 x 500    | -3309K             | £11.23       | £8.53         |
| 2 x 100 x 500   | -3310L             | £13.30       | £10.11        |

| Size           | Order Code CTL-413 | List Price/1 | Offer Price/1 |
|----------------|--------------------|--------------|---------------|
| 2 x 125 x 500  | -3311M             | £15.90       | £12.08        |
| 2 x 150 x 500  | -3312N             | £18.83       | £14.31        |
| 2 x 200 x 500  | -3313P             | £25.44       | £19.33        |
| 2 x 250 x 500  | -3314Q             | £30.65       | £23.29        |
| 2 x 300 x 500  | -3315R             | £34.89       | £26.52        |
| 3 x 3 x 500    | -3395W             | £6.62        | £5.03         |
| 3 x 10 x 500   | -3400A             | £4.83        | £3.67         |
| 3 x 15 x 500   | -3401B             | £5.40        | £4.10         |
| 3 x 20 x 500   | -3402C             | £6.19        | £4.70         |
| 3 x 25 x 500   | -3403D             | £6.85        | £5.21         |
| 3 x 30 x 500   | -3404E             | £7.47        | £5.68         |
| 3 x 40 x 500   | -3405F             | £8.38        | £6.37         |
| 3 x 50 x 500   | -3406G             | £9.81        | £7.46         |
| 3 x 60 x 500   | -3407H             | £11.04       | £8.39         |
| 3 x 75 x 500   | -3408J             | £13.14       | £9.99         |
| 3 x 80 x 500   | -3409K             | £14.21       | £10.80        |
| 3 x 100 x 500  | -3410L             | £16.92       | £12.86        |
| 3 x 125 x 500  | -3411M             | £19.61       | £14.90        |
| 3 x 150 x 500  | -3412N             | £23.70       | £18.01        |
| 3 x 200 x 500  | -3413P             | £30.32       | £23.04        |
| 3 x 250 x 500  | -3414Q             | £39.34       | £29.90        |
| 3 x 300 x 500  | -3415R             | £44.51       | £33.83        |
| 4 x 4 x 500    | -3495X             | £7.16        | £5.44         |
| 4 x 10 x 500   | -3500A             | £5.50        | £4.18         |
| 4 x 15 x 500   | -3501B             | £6.26        | £4.76         |
| 4 x 20 x 500   | -3502C             | £6.69        | £5.08         |
| 4 x 25 x 500   | -3503D             | £7.35        | £5.59         |
| 4 x 30 x 500   | -3504E             | £7.90        | £6.00         |
| 4 x 40 x 500   | -3505F             | £9.00        | £6.84         |
| 4 x 50 x 500   | -3506G             | £10.59       | £8.05         |
| 4 x 60 x 500   | -3507H             | £11.80       | £8.97         |
| 4 x 75 x 500   | -3508J             | £14.03       | £10.66        |
| 4 x 80 x 500   | -3509K             | £16.33       | £12.41        |
| 4 x 100 x 500  | -3510L             | £17.55       | £13.34        |
| 4 x 125 x 500  | -3511M             | £20.56       | £15.63        |
| 4 x 150 x 500  | -3512N             | £24.94       | £18.95        |
| 4 x 200 x 500  | -3513P             | £32.03       | £24.34        |
| 4 x 250 x 500  | -3514Q             | £40.56       | £30.83        |
| 4 x 300 x 500  | -3515R             | £46.22       | £35.13        |
| 5 x 5 x 500    | -3595X             | £7.76        | £5.90         |
| 5 x 10 x 500   | -3600A             | £6.21        | £4.72         |
| 5 x 15 x 500   | -3601B             | £6.93        | £5.27         |
| 5 x 20 x 500   | -3602C             | £7.90        | £6.00         |
| 5 x 25 x 500   | -3603D             | £8.71        | £6.62         |
| 5 x 30 x 500   | -3604E             | £9.31        | £7.08         |
| 5 x 40 x 500   | -3605F             | £10.52       | £8.00         |
| 5 x 50 x 500   | -3606G             | £12.16       | £9.24         |
| 5 x 60 x 500   | -3607H             | £13.71       | £10.42        |
| 5 x 75 x 500   | -3608J             | £16.33       | £12.41        |
| 5 x 80 x 500   | -3609K             | £17.99       | £13.67        |
| 5 x 100 x 500  | -3610L             | £20.99       | £15.95        |
| 5 x 125 x 500  | -3611M             | £24.23       | £18.41        |
| 5 x 150 x 500  | -3612N             | £28.04       | £21.31        |
| 5 x 200 x 500  | -3613P             | £37.89       | £28.80        |
| 5 x 250 x 500  | -3614Q             | £49.67       | £37.75        |
| 5 x 300 x 500  | -3615R             | £57.21       | £43.48        |
| 6 x 6 x 500    | -3700A             | £6.71        | £5.10         |
| 6 x 10 x 500   | -3701B             | £7.66        | £5.82         |
| 6 x 15 x 500   | -3702C             | £8.38        | £6.37         |
| 6 x 20 x 500   | -3703D             | £8.95        | £6.80         |
| 6 x 25 x 500   | -3704E             | £10.09       | £7.67         |
| 6 x 30 x 500   | -3705F             | £10.59       | £8.05         |
| 6 x 40 x 500   | -3706G             | £12.00       | £9.12         |
| 6 x 40 x 1000  | -3706T             | £49.65       | £37.73        |
| 6 x 50 x 500   | -3707H             | £13.66       | £10.38        |
| 6 x 60 x 500   | -3708J             | £15.47       | £11.76        |
| 6 x 75 x 500   | -3709K             | £18.73       | £14.23        |
| 6 x 80 x 500   | -3710L             | £19.56       | £14.87        |
| 6 x 100 x 500  | -3711M             | £23.50       | £17.86        |
| 6 x 125 x 500  | -3712N             | £28.39       | £21.58        |
| 6 x 150 x 500  | -3713P             | £33.52       | £25.48        |
| 6 x 200 x 500  | -3714Q             | £43.27       | £32.89        |
| 6 x 250 x 500  | -3715R             | £58.90       | £44.76        |
| 6 x 300 x 500  | -3716S             | £67.90       | £51.60        |
| 8 x 8 x 500    | -3800A             | £9.37        | £7.12         |
| 8 x 10 x 500   | -3801B             | £8.50        | £6.46         |
| 8 x 15 x 500   | -3802C             | £9.42        | £7.16         |
| 8 x 20 x 500   | -3803D             | £10.64       | £8.09         |
| 8 x 25 x 500   | -3804E             | £11.88       | £9.03         |
| 8 x 30 x 500   | -3805F             | £13.30       | £10.11        |
| 8 x 40 x 500   | -3806G             | £15.54       | £11.81        |
| 8 x 50 x 500   | -3807H             | £17.83       | £13.55        |
| 8 x 60 x 500   | -3808J             | £19.73       | £14.99        |
| 8 x 75 x 500   | -3809K             | £23.03       | £17.50        |
| 8 x 80 x 500   | -3810L             | £24.66       | £18.74        |
| 8 x 100 x 500  | -3811M             | £28.35       | £21.55        |
| 8 x 125 x 500  | -3812N             | £34.01       | £25.85        |
| 8 x 150 x 500  | -3813P             | £42.22       | £32.09        |
| 8 x 200 x 500  | -3814Q             | £54.05       | £41.08        |
| 8 x 250 x 500  | -3815R             | £67.57       | £51.35        |
| 8 x 300 x 500  | -3816S             | £79.78       | £60.63        |
| 10 x 10 x 500  | -3900A             | £9.61        | £7.30         |
| 10 x 15 x 500  | -3901B             | £11.16       | £8.48         |
| 10 x 20 x 500  | -3902C             | £12.64       | £9.61         |
| 10 x 25 x 500  | -3903D             | £14.11       | £10.72        |
| 10 x 25 x 1000 | -3903R             | £28.23       | £21.45        |
| 10 x 30 x 500  | -3904E             | £15.70       | £11.93        |
| 10 x 40 x 500  | -3905F             | £17.66       | £13.42        |
| 10 x 40 x 1000 | -3905T             | £35.32       | £26.84        |

| Size            | Order Code CTL-413 | List Price/1 | Offer Price/1 |
|-----------------|--------------------|--------------|---------------|
| 10 x 50 x 500   | -3906G             | £20.32       | £15.44        |
| 10 x 50 x 1000  | -3906S             | £40.65       | £30.89        |
| 10 x 60 x 500   | -3907H             | £23.29       | £17.70        |
| 10 x 70 x 500   | -3908E             | £29.75       | £22.61        |
| 10 x 75 x 500   | -3908J             | £29.37       | £22.32        |
| 10 x 80 x 500   | -3909K             | £27.18       | £20.66        |
| 10 x 100 x 500  | -3910L             | £31.65       | £24.05        |
| 10 x 125 x 500  | -3911M             | £38.47       | £29.24        |
| 10 x 150 x 500  | -3912N             | £48.09       | £36.55        |
| 10 x 200 x 500  | -3913P             | £59.55       | £45.26        |
| 10 x 250 x 500  | -3914Q             | £111.55      | £84.78        |
| 10 x 300 x 500  | -3915R             | £113.15      | £85.99        |
| 12 x 12 x 500   | -4100A             | £13.57       | £10.31        |
| 12 x 15 x 500   | -4101B             | £13.33       | £10.13        |
| 12 x 20 x 500   | -4102C             | £13.54       | £10.29        |
| 12 x 20 x 1000  | -4102J             | £27.07       | £20.57        |
| 12 x 25 x 500   | -4103D             | £16.92       | £12.86        |
| 12 x 30 x 500   | -4104E             | £18.18       | £13.82        |
| 12 x 40 x 500   | -4105F             | £19.43       | £14.77        |
| 12 x 50 x 500   | -4106G             | £22.37       | £17.00        |
| 12 x 60 x 500   | -4107H             | £25.01       | £19.01        |
| 12 x 75 x 500   | -4108J             | £30.15       | £22.91        |
| 12 x 80 x 500   | -4109K             | £31.65       | £24.05        |
| 12 x 100 x 500  | -4110L             | £39.31       | £29.88        |
| 12 x 125 x 500  | -4111M             | £45.36       | £34.47        |
| 12 x 150 x 500  | -4112N             | £53.84       | £40.92        |
| 12 x 200 x 500  | -4113P             | £70.83       | £53.83        |
| 12 x 250 x 500  | -4114Q             | £86.73       | £65.91        |
| 12 x 300 x 500  | -4115R             | £104.86      | £79.69        |
| 15 x 15 x 500   | -4200A             | £14.52       | £11.04        |
| 15 x 20 x 500   | -4201B             | £15.70       | £11.93        |
| 15 x 25 x 500   | -4202C             | £17.62       | £13.39        |
| 15 x 30 x 500   | -4203D             | £19.07       | £14.49        |
| 15 x 40 x 500   | -4204E             | £21.54       | £16.37        |
| 15 x 50 x 500   | -4205F             | £23.85       | £18.13        |
| 15 x 60 x 500   | -4206G             | £28.44       | £21.61        |
| 15 x 75 x 500   | -4207H             | £33.76       | £25.66        |
| 15 x 80 x 500   | -4208J             | £36.39       | £27.66        |
| 15 x 100 x 500  | -4209K             | £43.22       | £32.85        |
| 15 x 125 x 500  | -4210L             | £52.91       | £40.21        |
| 15 x 150 x 500  | -4211M             | £62.74       | £47.68        |
| 15 x 200 x 500  | -4212N             | £82.11       | £62.40        |
| 15 x 250 x 500  | -4213P             | £101.10      | £76.84        |
| 15 x 300 x 500  | -4214Q             | £120.18      | £91.34        |
| 16 x 16 x 500   | -4250A             | £16.70       | £12.69        |
| 16 x 25 x 500   | -4252C             | £20.90       | £15.88        |
| 20 x 20 x 500   | -4300A             | £19.64       | £14.93        |
| 20 x 25 x 500   | -4301B             | £20.85       | £15.85        |
| 20 x 30 x 500   | -4302C             | £21.71       | £16.50        |
| 20 x 40 x 500   | -4303D             | £23.03       | £17.50        |
| 20 x 50 x 500   | -4304E             | £27.55       | £20.94        |
| 20 x 50 x 1000  | -4304R             | £55.10       | £41.88        |
| 20 x 60 x 500   | -4305F             | £33.27       | £25.29        |
| 20 x 75 x 500   | -4306G             | £39.22       | £29.81        |
| 20 x 80 x 500   | -4307H             | £44.14       | £33.55        |
| 20 x 100 x 500  | -4308J             | £52.46       | £39.87        |
| 20 x 125 x 500  | -4309K             | £61.83       | £46.99        |
| 20 x 125 x 1000 | -4310A             | £123.66      | £93.98        |
| 20 x 150 x 500  | -4310L             | £73.59       | £55.93        |
| 20 x 200 x 500  | -4311M             | £102.35      | £77.79        |
| 20 x 250 x 500  | -4312N             | £118.62      | £90.15        |
| 25 x 25 x 500   | -4400A             | £28.90       | £21.96        |
| 25 x 30 x 500   | -4401B             | £25.20       | £19.15        |
| 25 x 40 x 500   | -4402C             | £29.56       | £22.47        |
| 25 x 50 x 500   | -4403D             | £37.58       | £28.56        |
| 25 x 60 x 500   | -4404E             | £46.90       | £35.64        |
| 25 x 75 x 500   | -4405F             | £53.05       | £40.32        |
| 25 x 80 x 500   | -4406G             | £59.93       | £45.55        |
| 25 x 100 x 500  | -4407H             | £66.55       | £50.58        |
| 25 x 125 x 500  | -4408J             | £78.41       | £59.59        |
|                 |                    |              |               |

Precision Ground Flat Stock

Inche Sizes

Tolerances: Thickness +/-0.001", Width +0.005"/-nil, Length Nominal.

Table with columns: Size, Order Code CTL-413, List Price/1, Offer Price/1. Lists various flat stock sizes from 1/32" to 5/32" in increments.

Table with columns: Size, Order Code CTL-413, List Price/1, Offer Price/1. Continues listing flat stock sizes from 5/32" to 3/8" in increments.

Table with columns: Size, Order Code CTL-413, List Price/1, Offer Price/1. Continues listing flat stock sizes from 3/8" to 2" in increments.

Workshop Equipment

**GROUP 420 RACK CLAMPS**

**CARVER CLAMPS** *Rack Clamps*

Consist of a J shape notched bar and sliding jaw. Finished in a bright orange epoxy coating for durability. Uses include metal fabrication, welding, moulding box and die holding, pattern making, plastic and fibreglass moulding and plate fabrication. No long screws to bend, or critical working parts exposed to weld spatter. The action of tightening the clamps does not impose rotation to the workpiece. The jaws may be reversed and the clamp used in reverse action.



| Product Number | Description (Duty) | Capacity (mm)(Inch) | Reach (mm)(Inch)                      | Overall Length                          | Load daN | Weight each | Order Code CVR-420 | List Price/1 | Offer Price/1  |
|----------------|--------------------|---------------------|---------------------------------------|---|----------|-------------|--------------------|--------------|----------------|
| T186-150       | Standard           | 150 (6")            | 60 (2 <sup>3</sup> / <sub>8</sub> ")  | 245 (9 <sup>3</sup> / <sub>4</sub> ")   | 1130     | 1.4kg       | <b>-4024C</b>      | £65.14       | <b>£59.28</b>  |
| T186-300       |                    | 300 (12")           | 60 (2 <sup>3</sup> / <sub>8</sub> ")  | 395 (15 <sup>1</sup> / <sub>2</sub> ")  | 1130     | 1.8kg       | <b>-4028C</b>      | £76.06       | <b>£69.21</b>  |
| T186-500       |                    | 500 (20")           | 60 (2 <sup>3</sup> / <sub>8</sub> ")  | 640 (25 <sup>1</sup> / <sub>8</sub> ")  | 1130     | 2.5kg       | <b>-4038C</b>      | £87.95       | <b>£80.03</b>  |
| T186-750       |                    | 750 (30")           | 60 (2 <sup>3</sup> / <sub>8</sub> ")  | 890 (35 <sup>1</sup> / <sub>2</sub> ")  | 1130     | 3.2kg       | <b>-4046C</b>      | £94.59       | <b>£86.08</b>  |
| T321-250       | Standard Long      | 250 (10")           | 120 (4 <sup>3</sup> / <sub>4</sub> ") | 360 (14 <sup>1</sup> / <sub>2</sub> ")  | 565      | 4.2kg       | <b>-4224C</b>      | £99.10       | <b>£90.18</b>  |
| T290-225       | Medium             | 225 (9")            | 90 (3 <sup>1</sup> / <sub>2</sub> ")  | 420 (16 <sup>1</sup> / <sub>2</sub> ")  | 1800     | 5.5kg       | <b>-4174C</b>      | £165.40      | <b>£150.51</b> |
| T290-450       |                    | 450 (18")           | 90 (3 <sup>1</sup> / <sub>2</sub> ")  | 655 (25 <sup>3</sup> / <sub>8</sub> ")  | 1800     | 7.0kg       | <b>-4178C</b>      | £183.00      | <b>£166.53</b> |
| T290-750       |                    | 750 (30")           | 90 (3 <sup>1</sup> / <sub>2</sub> ")  | 959 (37 <sup>3</sup> / <sub>4</sub> ")  | 1800     | 8.5kg       | <b>-4186C</b>      | £274.20      | <b>£249.52</b> |
| T285-225       | Medium Long        | 225 (9")            | 200 (8")                              | 420 (16 <sup>1</sup> / <sub>2</sub> ")  | 900      | 7.1kg       | <b>-4134C</b>      | £191.85      | <b>£174.58</b> |
| T285-450       |                    | 450 (18")           | 200 (8")                              | 655 (25 <sup>3</sup> / <sub>8</sub> ")  | 900      | 8.5kg       | <b>-4138C</b>      | £217.83      | <b>£198.23</b> |
| T257-150       | Heavy              | 150 (6")            | 115 (4 <sup>1</sup> / <sub>2</sub> ") | 403 (15 <sup>7</sup> / <sub>8</sub> ")  | 2700     | 9.8kg       | <b>-4084C</b>      | £243.64      | <b>£221.71</b> |
| T257-300       |                    | 300 (12")           | 115 (4 <sup>1</sup> / <sub>2</sub> ") | 555 (21 <sup>7</sup> / <sub>8</sub> ")  | 2700     | 10.9kg      | <b>-4088C</b>      | £266.92      | <b>£242.90</b> |
| T257-450       |                    | 450 (18")           | 115 (4 <sup>1</sup> / <sub>2</sub> ") | 710 (27 <sup>3</sup> / <sub>4</sub> ")  | 2700     | 12.2kg      | <b>-4092C</b>      | £284.51      | <b>£258.90</b> |
| T257-600       |                    | 600 (24")           | 115 (4 <sup>1</sup> / <sub>2</sub> ") | 850 (33 <sup>1</sup> / <sub>2</sub> ")  | 2700     | 13.1kg      | <b>-4096C</b>      | £303.94      | <b>£276.59</b> |
| T257-900       |                    | 900 (36")           | 115 (4 <sup>1</sup> / <sub>2</sub> ") | 1165 (45 <sup>3</sup> / <sub>4</sub> ") | 2700     | 15.8kg      | <b>-4100C</b>      | £344.65      | <b>£313.63</b> |

**Bar Clamps**

Finished in a bright orange epoxy coating for durability. For tough jobs in engineering applications. Carver bar clamps are supplied complete, with notched bar and two reversible jaws, easily positioned to workpiece before tightening.



**Spare Jaws Supplied as Singles**

| To Suit Bar | Order Code CVR-420 | List Price/1 | Offer Price/1  |
|-------------|--------------------|--------------|----------------|
| T186        | <b>-4020J</b>      | £34.82       | <b>£31.69</b>  |
| T257        | <b>-4080J</b>      | £151.13      | <b>£137.53</b> |
| T285        | <b>-4130J</b>      | £102.51      | <b>£93.28</b>  |
| T290        | <b>-4170J</b>      | £87.09       | <b>£79.25</b>  |
| T321        | <b>-4220J</b>      | £40.14       | <b>£36.53</b>  |

| Product Number | Description (Duty) | Capacity (mm) (Inch) | Reach (mm) (Inch)                     | Overall Length                          | Load daN | Weight each | Order Code CVR-420 | List Price/1 | Offer Price/1  |
|----------------|--------------------|----------------------|---------------------------------------|---|----------|-------------|--------------------|--------------|----------------|
| T186-600       | Standard           | 600 (24")            | 60 (2 <sup>3</sup> / <sub>8</sub> ")  | 710 (27 <sup>3</sup> / <sub>4</sub> ")  | 1130     | 3.4kg       | <b>-4042C</b>      | £127.11      | <b>£115.67</b> |
| T186-900       |                    | 900 (36")            | 60 (2 <sup>3</sup> / <sub>8</sub> ")  | 1020 (40 <sup>1</sup> / <sub>8</sub> ") | 1130     | 4.4kg       | <b>-4050C</b>      | £136.17      | <b>£123.91</b> |
| T186-1500      |                    | 1500 (60")           | 60 (2 <sup>3</sup> / <sub>8</sub> ")  | 1625 (64")                              | 1130     | 5.8kg       | <b>-4058C</b>      | £162.51      | <b>£147.88</b> |
| T321-600       | Standard Long      | 600 (24")            | 120 (4 <sup>3</sup> / <sub>8</sub> ") | 710 (27 <sup>3</sup> / <sub>4</sub> ")  | 565      | 3.50kg      | <b>-4234C</b>      | £118.62      | <b>£107.94</b> |
| T290-900       | Medium             | 900 (36")            | 90 (3 <sup>1</sup> / <sub>2</sub> ")  | 1070 (42 <sup>1</sup> / <sub>8</sub> ") | 1800     | 10.5kg      | <b>-4190C</b>      | £283.21      | <b>£257.72</b> |
| T290-1500      |                    | 1500 (60")           | 90 (3 <sup>1</sup> / <sub>2</sub> ")  | 1690 (66 <sup>1</sup> / <sub>2</sub> ") | 1800     | 14.0kg      | <b>-4202C</b>      | £335.35      | <b>£305.17</b> |

Workshop Equipment

**KENNEDY** Industrial  
QUALITY INDUSTRIAL TOOLING® **Key Steel**

High grade mild steel. Available in square or rectangular sections.  
Metric manufactured from: **BS4235 Part 7 1972 grade steel**  
equivalent to **DIN 6885**.  
Inch manufactured from: **BS46 PART 7 1958**  
**grade steel.**  
**Length:** 300mm and 12".  
Other sizes available on request.

**EXTENDED RANGE**

**Set Metric Square**

**Contents:** 4, 5, 6, 8, 10 and 12mm Square.

| No. of Pieces | Weight each | Order Code    | List Price/1 | Offer Price/1 |
|---------------|-------------|---------------|--------------|---------------|
| 6             | 850g        | <b>-0500K</b> | £19.90       | <b>£13.53</b> |

**Square — Metric**

| Type      | Size | Weight each | Order Code    | List Price/1 | Offer Price/1 |
|-----------|------|-------------|---------------|--------------|---------------|
| <b>mm</b> | 2mm  |             | <b>-0020K</b> | £2.56        | <b>£1.74</b>  |
|           | 3mm  |             | <b>-0030K</b> | £2.32        | <b>£1.58</b>  |
|           | 4mm  | 40g         | <b>-0040K</b> | £1.94        | <b>£1.32</b>  |
|           | 5mm  | 60g         | <b>-0050K</b> | £2.66        | <b>£1.81</b>  |
|           | 6mm  | 90g         | <b>-0060K</b> | £2.75        | <b>£1.87</b>  |
|           | 7mm  | 135g        | <b>-0070K</b> | £3.55        | <b>£2.41</b>  |
|           | 8mm  | 160g        | <b>-0080K</b> | £4.05        | <b>£2.75</b>  |
|           | 10mm | 250g        | <b>-0100K</b> | £5.11        | <b>£3.47</b>  |
|           | 12mm | 350g        | <b>-0120K</b> | £6.26        | <b>£4.26</b>  |
|           | 14mm | 490g        | <b>-0140K</b> | £7.17        | <b>£4.88</b>  |
|           | 16mm |             | <b>-0160K</b> | £9.82        | <b>£6.68</b>  |
|           | 18mm |             | <b>-0180K</b> | £13.06       | <b>£8.88</b>  |
|           | 20mm |             | <b>-0200K</b> | £26.07       | <b>£17.73</b> |
|           | 22mm |             | <b>-0220K</b> | £30.42       | <b>£20.69</b> |
|           | 25mm |             | <b>-0250K</b> | £39.84       | <b>£27.09</b> |

**Square — Inch**

| Type        | Size   | Weight each   | Order Code    | List Price/1  | Offer Price/1 |
|-------------|--------|---------------|---------------|---------------|---------------|
| <b>inch</b> | 3/32"  |               | <b>-3060K</b> | £6.39         | <b>£4.35</b>  |
|             | 1/8"   | 20g           | <b>-3080K</b> | £1.59         | <b>£1.08</b>  |
|             | 5/32"  |               | <b>-3100K</b> | £2.95         | <b>£2.01</b>  |
|             | 3/16"  | 60g           | <b>-3120K</b> | £1.79         | <b>£1.22</b>  |
|             | 1/4"   | 100g          | <b>-3160K</b> | £2.31         | <b>£1.57</b>  |
|             | 5/16"  | 160g          | <b>-3200K</b> | £2.74         | <b>£1.86</b>  |
|             | 3/8"   | 220g          | <b>-3240K</b> | £3.70         | <b>£2.52</b>  |
|             | 7/16"  |               | <b>-3280K</b> | £4.80         | <b>£3.26</b>  |
|             | 1/2"   | 400g          | <b>-3320K</b> | £5.36         | <b>£3.64</b>  |
|             | 9/16"  |               | <b>-3360K</b> | £13.31        | <b>£9.05</b>  |
|             | 5/8"   | 910g          | <b>-3400K</b> | £11.79        | <b>£8.02</b>  |
|             | 3/4"   |               | <b>-3440K</b> | £8.42         | <b>£5.73</b>  |
|             | 13/16" |               | <b>-3520K</b> | £18.46        | <b>£12.55</b> |
|             | 7/8"   |               | <b>-3560K</b> | £15.57        | <b>£10.59</b> |
|             | 1"     |               | <b>-3640K</b> | £18.61        | <b>£12.65</b> |
| 1 1/4"      |        | <b>-3740K</b> | £39.34        | <b>£26.75</b> |               |

**Rectangular — Metric**

| Type      | Size      | Weight each | Order Code    | List Price/1 | Offer Price/1 |
|-----------|-----------|-------------|---------------|--------------|---------------|
| <b>mm</b> | 8 x 5mm   |             | <b>-0850K</b> | £5.32        | <b>£3.62</b>  |
|           | 8 x 7mm   | 140g        | <b>-0870K</b> | £3.74        | <b>£2.54</b>  |
|           | 10 x 6mm  |             | <b>-1060K</b> | £5.74        | <b>£3.90</b>  |
|           | 10 x 8mm  | 200g        | <b>-1080K</b> | £5.06        | <b>£3.44</b>  |
|           | 12 x 8mm  | 240g        | <b>-1280K</b> | £8.28        | <b>£5.63</b>  |
|           | 12 x 10mm |             | <b>-1300K</b> | £9.85        | <b>£6.70</b>  |
|           | 14 x 9mm  | 310g        | <b>-1490K</b> | £6.57        | <b>£4.47</b>  |
|           | 16 x 10mm | 390g        | <b>-1610K</b> | £12.88       | <b>£8.76</b>  |
|           | 18 x 11mm | 490g        | <b>-1910K</b> | £15.38       | <b>£10.46</b> |
|           | 20 x 12mm | 590g        | <b>-2120K</b> | £17.64       | <b>£12.00</b> |
|           | 22 x 14mm |             | <b>-2400K</b> | £22.33       | <b>£15.18</b> |
|           | 25 x 14mm |             | <b>-2420K</b> | £25.44       | <b>£17.30</b> |
|           | 28 x 16mm |             | <b>-2550K</b> | £31.82       | <b>£21.64</b> |
|           | 32 x 18mm |             | <b>-2650K</b> | £39.73       | <b>£27.02</b> |
|           | 36 x 20mm |             | <b>-2700K</b> | £50.27       | <b>£34.18</b> |

**Rectangular — Inch**

| Type          | Size          | Weight each   | Order Code    | List Price/1  | Offer Price/1 |
|---------------|---------------|---------------|---------------|---------------|---------------|
| <b>inch</b>   | 5/16" x 1/4"  |               | <b>-4200K</b> | £3.41         | <b>£2.32</b>  |
|               | 3/8" x 1/4"   |               | <b>-4230K</b> | £3.78         | <b>£2.57</b>  |
|               | 3/8" x 5/16"  |               | <b>-4240K</b> | £4.54         | <b>£3.09</b>  |
|               | 7/16" x 5/16" |               | <b>-4270K</b> | £4.85         | <b>£3.30</b>  |
|               | 7/16" x 3/8"  |               | <b>-4280K</b> | £5.29         | <b>£3.60</b>  |
|               | 1/2" x 5/16"  |               | <b>-4310K</b> | £4.99         | <b>£3.39</b>  |
|               | 1/2" x 3/8"   |               | <b>-4320K</b> | £6.72         | <b>£4.57</b>  |
|               | 5/8" x 3/8"   |               | <b>-4460K</b> | £7.94         | <b>£5.40</b>  |
|               | 5/8" x 7/16"  |               | <b>-4480K</b> | £8.78         | <b>£5.97</b>  |
|               | 5/8" x 1/2"   |               | <b>-4500K</b> | £9.96         | <b>£6.77</b>  |
|               | 3/4" x 1/8"   |               | <b>-4580K</b> | £6.58         | <b>£4.47</b>  |
|               | 3/4" x 1/4"   |               | <b>-4600K</b> | £9.67         | <b>£6.58</b>  |
|               | 3/4" x 1/2"   |               | <b>-4680K</b> | £11.32        | <b>£7.70</b>  |
|               | 7/8" x 5/8"   |               | <b>-4800K</b> | £17.95        | <b>£12.21</b> |
|               | 1" x 5/8"     |               | <b>-4920K</b> | £26.01        | <b>£17.69</b> |
| 1" x 3/4"     |               | <b>-4960K</b> | £25.31        | <b>£17.21</b> |               |
| 1 1/4" x 7/8" |               | <b>-5140K</b> | £28.49        | <b>£19.37</b> |               |

**Square - Metric Stainless Steel**

| Type      | Size (mm) | Weight each | Order Code    | List Price/1 | Offer Price/1 |
|-----------|-----------|-------------|---------------|--------------|---------------|
| <b>mm</b> | 4 x 4     |             | <b>-8040K</b> | £10.78       | <b>£7.98</b>  |
|           | 5 x 5     |             | <b>-8050K</b> | £13.34       | <b>£9.87</b>  |
|           | 6 x 6     |             | <b>-8060K</b> | £12.32       | <b>£9.12</b>  |
|           | 8 x 7     |             | <b>-8400K</b> | £12.78       | <b>£9.46</b>  |
|           | 8 x 8     |             | <b>-8080K</b> | £14.56       | <b>£10.77</b> |
|           | 10 x 8    |             | <b>-8420K</b> | £13.62       | <b>£10.08</b> |
|           | 10 x 10   |             | <b>-8100K</b> | £19.70       | <b>£14.58</b> |
|           | 12 x 10   |             | <b>-8440K</b> | £14.38       | <b>£10.64</b> |
|           | 12 x 12   |             | <b>-8120K</b> | £22.80       | <b>£16.87</b> |
|           | 14 x 9    |             | <b>-8460K</b> | £26.76       | <b>£19.80</b> |

**INDEXA** Indexa T-Slot Clamping Kits

Designed to save set up time and solve most T-Slot clamping problems. All Components are manufactured from **S45C (JIS)/CK45 (DIN)** grade non-alloy carbon steel. Heat treated to HRC 28 - 32 and have a manganese phosphate surface finish. Supplied in a robust plastic case.



| T-Slot Size | Thread Size | Part Number | Weight each | Order Code    | List Price/1 | Offer Price/1  |
|-------------|-------------|-------------|-------------|---------------|--------------|----------------|
| 12mm        | M10         | TK10        | 9kg         | <b>-3610T</b> | £142.00      | <b>£116.44</b> |
| 14mm        | M12         | TK12        | 10kg        | <b>-3612T</b> | £143.00      | <b>£117.26</b> |
| 16mm        | M14         | TK14        | 11kg        | <b>-3614T</b> | £160.00      | <b>£131.20</b> |
| 18mm        | M16         | TK16        | 14kg        | <b>-3616T</b> | £226.00      | <b>£185.32</b> |
| 20mm        | M18         | TK18        | 20.5kg      | <b>-3618T</b> | £252.00      | <b>£206.64</b> |

**CONTRACT PRICES AVAILABLE FOR VOLUME PURCHASES**

All Prices Exclude V.A.T. © 2011



Designed to save set up time and solve most clamping problems. Manufactured to high standards. All step clamps are forged and hardened and the step blocks are made from high quality steel. All components (other than the studs) are heat treated and finished in black oxide. Available to suit a full range of metric and imperial T-Slot widths. Supplied in steel racks which can be wall mounted or fitted to workbenches for ease of storage (except M16 set which is supplied in wooden box).

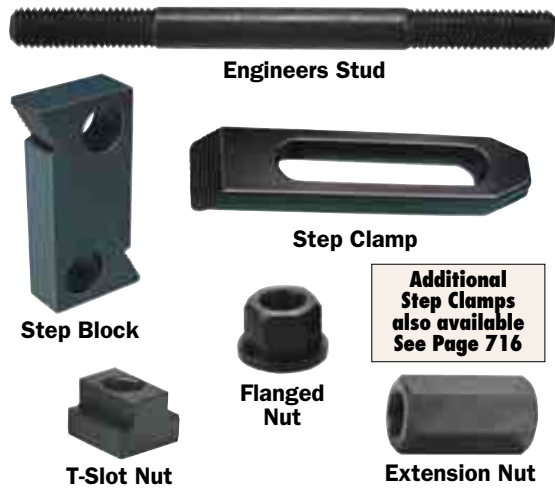

**Additional  
Step Clamps  
also available  
See Page 716**

**58 Pieces Metric Sets** (Quantity of each component part given in brackets)

| Product Number | Table Slot Size x W x L (mm) | Thread Size | Engineers Stud L x Thread L (mm)  | Step Clamp L x W x H (mm)                                  | Extension Nuts      | Flange Nuts    | Step H         | Blocks (Pairs) Adj. Range                  | Weight each | Order Code ATL-425 | List Price/1 | Offer Price/1 |
|----------------|------------------------------|-------------|---|--|---------------------|----------------|----------------|--|-------------|--------------------|--------------|---------------|
| CK120100       | 12 x 18 x 14 (6)             | M10         | 75 x 30 (4)<br>100 x 30 (4)<br>125 x 30 (4)<br>150 x 30 (4)<br>175 x 30 (4)<br>200 x 30 (4) | 55 x 25 x 12 (2)<br>88 x 25 x 16 (2)<br>128 x 28 x 19 (2)  | M10 x 30mm Long (4) | M10 x 15mm (6) | 28<br>35<br>98 | 20 - 38 (4)<br>28 - 64 (4)<br>64 - 152 (4) | 10kg        | -1120K             | £81.95       | £68.02        |
| CK140120       | 14 x 22 x 16 (6)             | M12         | 75 x 35 (4)<br>100 x 35 (4)<br>125 x 35 (4)<br>150 x 35 (4)<br>175 x 35 (4)<br>200 x 35 (4) | 64 x 28 x 12 (2)<br>100 x 32 x 19 (2)<br>150 x 32 x 22 (2) | M12 x 36mm Long (4) | M12 x 18mm (6) | 28<br>35<br>98 | 20 - 38 (4)<br>28 - 64 (4)<br>64 - 152 (4) | 12kg        | -1140K             | £81.95       | £68.02        |
| CK160140       | 16 x 25 x 18 (6)             | M14         | 75 x 35 (4)<br>100 x 35 (4)<br>125 x 35 (4)<br>150 x 35 (4)<br>175 x 35 (4)<br>200 x 35 (4) | 64 x 28 x 12 (2)<br>100 x 32 x 19 (2)<br>150 x 32 x 22 (2) | M14 x 42mm Long (4) | M14 x 21mm (6) | 28<br>35<br>98 | 20 - 38 (4)<br>28 - 64 (4)<br>64 - 152 (4) | 12kg        | -1160K             | £85.95       | £71.34        |
| CK180140       | 18 x 25 x 18 (6)             | M14         | 75 x 35 (4)<br>100 x 35 (4)<br>125 x 35 (4)<br>150 x 35 (4)<br>175 x 35 (4)<br>200 x 35 (4) | 64 x 28 x 12 (2)<br>100 x 32 x 19 (2)<br>150 x 32 x 22 (2) | M14 x 42mm Long (4) | M14 x 21mm (6) | 28<br>35<br>98 | 20 - 38 (4)<br>28 - 64 (4)<br>64 - 152 (4) | 12kg        | -1180K             | £85.95       | £71.34        |
| CK200160       | 20 x 28 x 20 (6)             | M16         | 75 x 35 (4)<br>100 x 35 (4)<br>125 x 35 (4)<br>150 x 35 (4)<br>175 x 35 (4)<br>200 x 35 (4) | 64 x 31 x 12 (2)<br>100 x 38 x 20 (2)<br>150 x 38 x 22 (2) | M16 x 48mm Long (4) | M16 x 24mm (6) | 28<br>35<br>98 | 20 - 38 (4)<br>28 - 64 (4)<br>64 - 152 (4) | 14kg        | -1200K             | £110.90      | £92.05        |

**58 Pieces Inch Sets** (Quantity of each component part given in brackets)

| Product Number | Table Slot Size x W x L (mm) | Thread Size | Engineers Stud L x Thread L (mm)   | Step Clamp L x H x W (mm)  | Extension Nuts             | Flange Nuts         | Step H           | Blocks (Pairs) Adj. Range                                   | Weight each | Order Code ATL-425 | List Price/1 | Offer Price/1 |
|----------------|------------------------------|-------------|--|--|----------------------------|---------------------|------------------|---|-------------|--------------------|--------------|---------------|
| CK500375       | 1/2" x 1 1/16" x 17/32" (6)  | 3/8" UNC    | 3" x 1 1/4" (4)<br>4" x 1 1/4" (4)<br>5" x 1 1/4" (4)<br>6" x 1 1/4" (4)<br>7" x 1 1/4" (4)<br>8" x 1 1/4" (4) | 2" x 1" x 1/2" (2)<br>3 1/2" x 1 1/4" x 3/4" (2)<br>5" x 1 1/4" x 7/8" (2)     | 3/8" UNC x 1" Long (4)     | 3/8" UNC 7/16" (6)  | 1 1/8"<br>1 3/4" | 3/4" - 1 1/2" (4)<br>1 1/8" - 2 1/2" (4)<br>2 1/2" - 6" (4) | 10kg        | -1320K             | £81.95       | £68.02        |
| CK62500        | 9/16" x 7/8" x 6/8" (6)      | 1/2" UNC    | 3" x 1 1/4" (4)<br>4" x 1 1/2" (4)<br>5" x 1 1/2" (4)<br>6" x 1 1/2" (4)<br>7" x 1 1/2" (4)<br>8" x 1 1/2" (4) | 2 1/2" x 1 1/8" x 1/2" (2)<br>2" x 1 1/4" x 3/4" (2)<br>6" x 1 1/4" x 7/8" (2) | 1/2" UNC x 1 1/4" Long (4) | 1/2" UNC 13/16" (6) | 1 1/8"<br>1 3/4" | 3/4" - 1 1/2" (4)<br>1 1/8" - 2 1/2" (4)<br>2 1/2" - 6" (4) | 12kg        | -1360K             | £85.95       | £71.34        |
| CK62550        | 5/8" x 7/8" x 6/8" (6)       | 1/2" UNC    | 3" x 1 1/4" (4)<br>4" x 1 1/2" (4)<br>5" x 1 1/2" (4)<br>6" x 1 1/2" (4)<br>7" x 1 1/2" (4)<br>8" x 1 1/2" (4) | 2 1/2" x 1 1/8" x 1/2" (2)<br>2" x 1 1/4" x 3/4" (2)<br>6" x 1 1/4" x 7/8" (2) | 1/2" UNC x 1 1/4" Long (4) | 1/2" UNC 13/16" (6) | 1 1/8"<br>1 3/4" | 3/4" - 1 1/2" (4)<br>1 1/8" - 2 1/2" (4)<br>2 1/2" - 6" (4) | 12kg        | -1400K             | £85.95       | £71.34        |
| CK750625       | 3/4" x 1 3/8" x 1 1/8" (6)   | 5/8" UNC    | 3" x 1 1/4" (4)<br>4" x 1 1/2" (4)<br>5" x 1 1/2" (4)<br>6" x 1 1/2" (4)<br>7" x 1 1/2" (4)<br>8" x 1 1/2" (4) | 2 1/2" x 1 1/8" x 1/2" (2)<br>2" x 1 1/4" x 3/4" (2)<br>6" x 1 1/4" x 7/8" (2) | 5/8" UNC x 1 5/8" Long (4) | 5/8" UNC 13/16" (6) | 1 1/8"<br>1 3/4" | 3/4" - 1 1/2" (4)<br>1 1/8" - 2 1/2" (4)<br>2 1/2" - 6" (4) | 12kg        | -1480K             | £110.90      | £92.05        |

Workshop Equipment

**INDEXA** BC02 - Square Hollow Block



Material: Cast Iron.  
BS. 1452 Gr. 250.

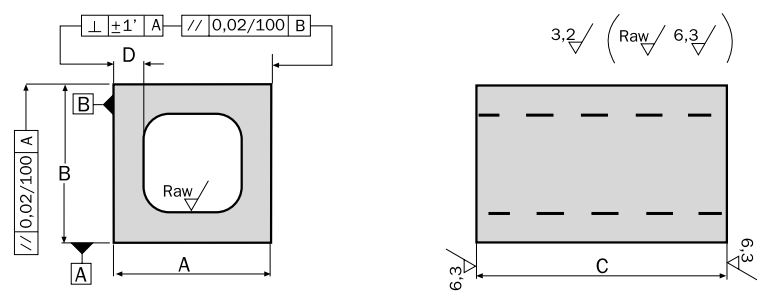

| Product Number | Size A x B x C    | Dimensions (mm) D | Weight each | Order Code IND-425 | List Price/1 | Offer Price/1 |
|----------------|-------------------|-------------------|-------------|--------------------|--------------|---------------|
| BC02100200     | 100 x 100 x 200mm | 16                | 8.0kg       | -4075D             | £102.00      | £93.84        |
| BC02100400     | 100 x 100 x 400mm | 16                | 16.0kg      | -4075N             | £187.00      | £172.04       |
| BC02160200     | 160 x 160 x 200mm | 20                | 16.5kg      | -4080D             | £239.00      | £219.88       |

BC10 - Steel Rectangular Plate

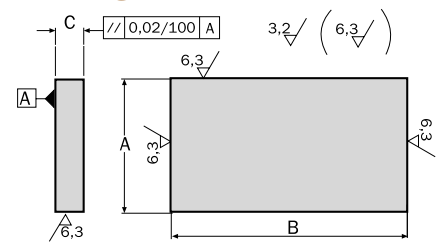

EXTENDED RANGE

Material: Steel.  
BS. 4360 Gr. 43A.



| Product Number | Size A x B  | Dimensions (mm) C | Weight each | Order Code IND-425 | List Price/1 | Offer Price/1 |
|----------------|-------------|-------------------|-------------|--------------------|--------------|---------------|
| BC10150200     | 150 x 200mm | 25                | 5.9kg       | -4180J             | £60.02       | £55.22        |
| BC10200200     | 200 x 200mm | 25                | 7.8kg       | -4180M             | £79.90       | £73.51        |
| BC10150250     | 150 x 250mm | 25                | 7.3kg       | -4180Q             | £79.60       | £73.23        |

CC01 - U-Clamp

Open end permits quick and easy installation.

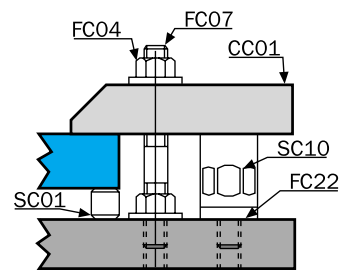
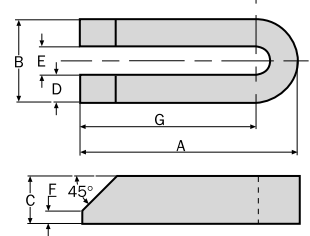

Material: Medium Carbon Steel.  
Heat Treated To: HRC 32 - 38.  
Surface Finish: Black Oxide.



| Product Number | Length x Width A x B | Dimensions (mm) |      |    |    |     | Weight each | Order Code IND-425 | List Price/1 | Offer Price/1 |
|----------------|----------------------|-----------------|------|----|----|-----|-------------|--------------------|--------------|---------------|
|                |                      | C               | D    | E  | F  | G   |             |                    |              |               |
| CC010112       | 100 x 38mm           | 22              | 12.5 | 13 | 6  | 81  | 0.41kg      | -1005D             | £11.76       | £10.82        |
| CC010316       | 150 x 50mm           | 30              | 16.5 | 17 | 8  | 125 | 1.10kg      | -1005J             | £24.26       | £22.32        |
| CC010420       | 200 x 60mm           | 35              | 19.5 | 21 | 10 | 170 | 2.10kg      | -1005M             | £40.79       | £37.53        |

CC02 - Bore Clamp

The cylindrical pin minimises the contact area. This clamp is for clamping inside horizontal bores and onto concave surfaces.

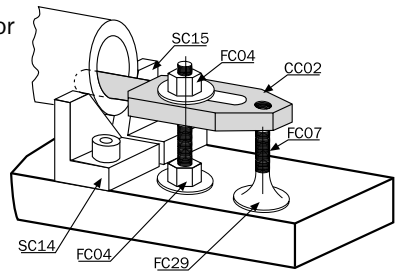
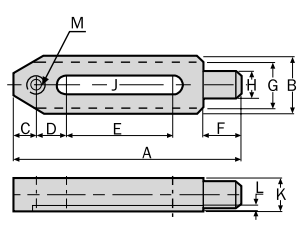

Material: Medium Carbon Steel.  
Heat Treated To: HR C32 - 38.  
Surface Finish: Black Oxide.



| Product Number | Length x Width A x B | Dimensions (mm) |    |     |    |    |    |    |    |   |     |        | Weight each | Order Code IND-425 | List Price/1 | Offer Price/1 |
|----------------|----------------------|-----------------|----|-----|----|----|----|----|----|---|-----|--------|-------------|--------------------|--------------|---------------|
|                |                      | C               | D  | E   | F  | G  | H  | J  | K  | L | M   |        |             |                    |              |               |
| CC020112       | 150 x 38mm           | 15              | 20 | 70  | 25 | 30 | 18 | 13 | 22 | 4 | M12 | 0.58kg | -1010D      | £20.08             | £18.47       |               |
| CC020216       | 150 x 48mm           | 20              | 25 | 40  | 35 | 40 | 24 | 17 | 32 | 5 | M16 | 1.12kg | -1010G      | £27.32             | £25.13       |               |
| CC020316       | 200 x 48mm           | 20              | 25 | 90  | 35 | 40 | 24 | 17 | 32 | 5 | M16 | 1.50kg | -1010J      | £34.17             | £31.44       |               |
| CC020420       | 200 x 60mm           | 30              | 35 | 60  | 40 | 50 | 28 | 21 | 35 | 6 | M20 | 2.22kg | -1010M      | £44.08             | £40.55       |               |
| CC020520       | 250 x 60mm           | 30              | 35 | 110 | 40 | 50 | 28 | 21 | 35 | 6 | M20 | 2.77kg | -1010P      | £53.56             | £49.28       |               |

CONTRACT PRICES AVAILABLE FOR VOLUME PURCHASES

All Prices Exclude V.A.T. © 2011

Workshop Equipment

**INDEXA** CC03 - *Swan Necked Clamp*

Low profile design helps eliminate cutter interference.



**Material:** Medium Carbon Steel.  
**Heat Treated To:** HRC 32 - 38.  
**Surface Finish:** Black Oxide.

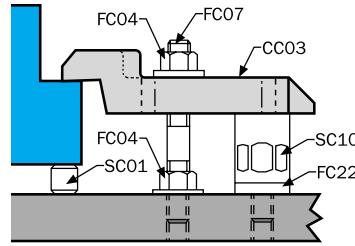
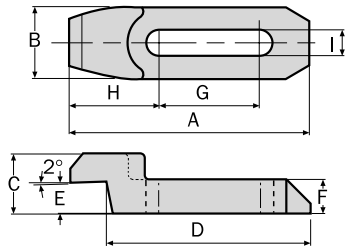

| Product Number | Length x Width<br>A x B | Dimensions (mm) |     |    |    |    |    |    | Weight each | Order Code<br><b>IND-425</b> | List Price/1 | Offer Price/1 |
|----------------|-------------------------|-----------------|-----|----|----|----|----|----|-------------|------------------------------|--------------|---------------|
|                |                         | C               | D   | E  | F  | G  | H  | I  |             |                              |              |               |
| CC030216       | 150 x 48mm              | 48              | 130 | 25 | 25 | 55 | 60 | 17 | 1.30kg      | <b>-1015K</b>                | £41.48       | <b>£38.16</b> |
| CC030320       | 175 x 60mm              | 60              | 150 | 30 | 30 | 65 | 70 | 21 | 2.26kg      | <b>-1015N</b>                | £63.66       | <b>£58.57</b> |

**CC04 - Tapped End U-Clamp**

Open end design permits easy assembly.

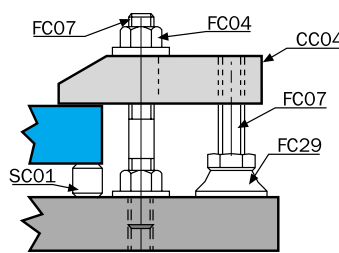
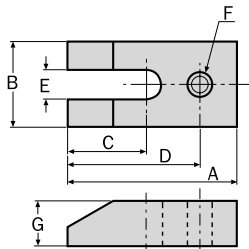

**Material:** Medium Carbon Steel.  
**Heat Treated To:** HRC 32 - 38.  
**Surface Finish:** Black Oxide.



| Product Number | Length x Width<br>A x B | Dimensions (mm) |     |    |     |    | Weight each | Order Code<br><b>IND-425</b> | List Price/1 | Offer Price/1 |
|----------------|-------------------------|-----------------|-----|----|-----|----|-------------|------------------------------|--------------|---------------|
|                |                         | C               | D   | E  | F   | G  |             |                              |              |               |
| CC040312       | 125 x 38mm              | 85              | 110 | 13 | M12 | 25 | 0.80kg      | <b>-1020J</b>                | £21.42       | <b>£19.71</b> |
| CC040416       | 100 x 48mm              | 45              | 80  | 17 | M16 | 25 | 1.10kg      | <b>-1020M</b>                | £24.06       | <b>£22.14</b> |
| CC040616       | 150 x 50mm              | 95              | 130 | 17 | M16 | 25 | 1.50kg      | <b>-1020R</b>                | £33.58       | <b>£30.89</b> |

**CC05 - Plain Clamp**

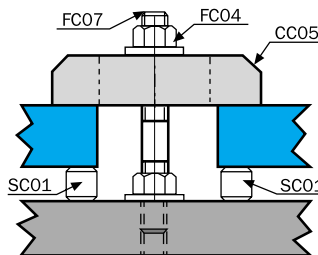
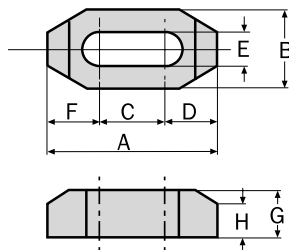

**Material:** Medium Carbon Steel.  
**Heat Treated To:** HRC 32 - 38.  
**Surface Finish:** Black Oxide.



| Product Number | Length x Width<br>A x B | Dimensions (mm) |      |    |      |    |    | Weight each | Order Code<br><b>IND-425</b> | List Price/1 | Offer Price/1 |
|----------------|-------------------------|-----------------|------|----|------|----|----|-------------|------------------------------|--------------|---------------|
|                |                         | C               | D    | E  | F    | G  | H  |             |                              |              |               |
| CC050112       | 65 x 32mm               | 25              | 20.0 | 13 | 20.0 | 19 | 13 | 0.22kg      | <b>-1025D</b>                | £11.60       | <b>£10.67</b> |
| CC050212       | 100 x 32mm              | 40              | 30.0 | 13 | 30.0 | 19 | 13 | 0.33kg      | <b>-1025G</b>                | £14.45       | <b>£13.29</b> |
| CC050316       | 80 x 38mm               | 24              | 28.0 | 17 | 28.0 | 22 | 14 | 0.34kg      | <b>-1025J</b>                | £13.56       | <b>£12.48</b> |
| CC050416       | 125 x 38mm              | 41              | 42.0 | 17 | 42.0 | 22 | 14 | 0.57kg      | <b>-1025M</b>                | £17.35       | <b>£15.96</b> |
| CC050520       | 100 x 38mm              | 32              | 34.0 | 21 | 34.0 | 22 | 14 | 0.41kg      | <b>-1025P</b>                | £15.12       | <b>£13.91</b> |
| CC050620       | 125 x 38mm              | 40              | 42.5 | 21 | 42.5 | 25 | 15 | 0.62kg      | <b>-1025R</b>                | £20.42       | <b>£18.79</b> |

**CC06 - Tapped End Plain Clamp**

For use with various knobs, jack screws, clamps and pads.

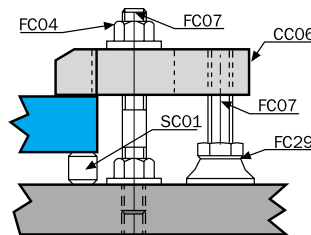
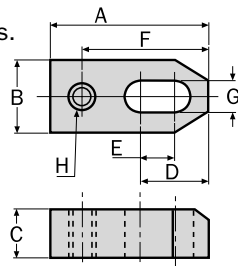

**Material:** Medium Carbon Steel.  
**Heat Treated To:** HRC 32 - 38.  
**Surface Finish:** Black Oxide.



| Product Number | Length x Width<br>A x B | Dimensions (mm) |     |    |     |    |     | Weight each | Order Code<br><b>IND-425</b> | List Price/1 | Offer Price/1 |
|----------------|-------------------------|-----------------|-----|----|-----|----|-----|-------------|------------------------------|--------------|---------------|
|                |                         | C               | D   | E  | F   | G  | H   |             |                              |              |               |
| CC060112       | 65 x 32mm               | 19              | 32  | 14 | 52  | 13 | M12 | 0.22kg      | <b>-1030D</b>                | £10.66       | <b>£9.81</b>  |
| CC060212       | 80 x 32mm               | 19              | 48  | 25 | 69  | 13 | M12 | 0.27kg      | <b>-1030F</b>                | £12.85       | <b>£11.82</b> |
| CC060312       | 100 x 32mm              | 19              | 60  | 40 | 89  | 13 | M12 | 0.33kg      | <b>-1030H</b>                | £15.26       | <b>£14.04</b> |
| CC060416       | 80 x 38mm               | 19              | 40  | 17 | 65  | 17 | M16 | 0.32kg      | <b>-1030J</b>                | £13.56       | <b>£12.48</b> |
| CC060516       | 100 x 38mm              | 25              | 55  | 30 | 85  | 17 | M16 | 0.53kg      | <b>-1030L</b>                | £19.05       | <b>£17.53</b> |
| CC060616       | 125 x 38mm              | 25              | 70  | 45 | 110 | 17 | M16 | 0.65kg      | <b>-1030N</b>                | £23.33       | <b>£21.46</b> |
| CC060720       | 150 x 50mm              | 25              | 82  | 50 | 134 | 21 | M20 | 1.10kg      | <b>-1030P</b>                | £29.42       | <b>£27.07</b> |
| CC060820       | 200 x 50mm              | 25              | 112 | 80 | 184 | 21 | M20 | 1.90kg      | <b>-1030R</b>                | £40.79       | <b>£37.53</b> |

Workshop Equipment

**INDEXA** CC07 - Slotted End Clamp

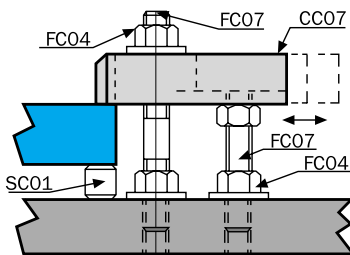
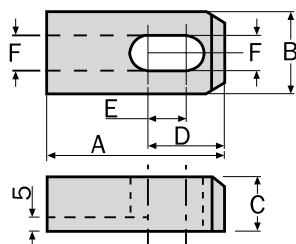

**Material:** Medium Carbon Steel.  
**Hardness:** HRC 32 - 38.  
**Surface Finish:** Black Oxide.



| Product Number | Length x Width<br>A x B | Dimensions (mm) |    |    |    |        | Weight each   | Order Code<br><b>IND-425</b> | List Price/1  | Offer Price/1 |
|----------------|-------------------------|-----------------|----|----|----|--------|---------------|------------------------------|---------------|---------------|
|                |                         | C               | D  | E  | F  | G      |               |                              |               |               |
| CC070112       | 65 x 32mm               | 22              | 32 | 14 | 13 | 0.18kg | <b>-1035D</b> | £10.54                       | <b>£9.70</b>  |               |
| CC070212       | 80 x 32mm               | 22              | 48 | 25 | 13 | 0.31kg | <b>-1035F</b> | £10.08                       | <b>£9.27</b>  |               |
| CC070416       | 80 x 38mm               | 22              | 40 | 17 | 17 | 0.38kg | <b>-1035J</b> | £13.67                       | <b>£12.58</b> |               |
| CC070516       | 100 x 38mm              | 22              | 55 | 30 | 17 | 0.53kg | <b>-1035L</b> | £16.54                       | <b>£15.22</b> |               |
| CC070616       | 125 x 38mm              | 25              | 70 | 45 | 17 | 0.65kg | <b>-1035N</b> | £18.95                       | <b>£17.43</b> |               |
| CC070720       | 150 x 50mm              | 25              | 82 | 50 | 21 | 1.10kg | <b>-1035P</b> | £25.57                       | <b>£23.52</b> |               |

**CC08 - Swing Clamp**

A small clamp with good holding power, ideal for tight spaces, full swing away feature permits easy part loading.

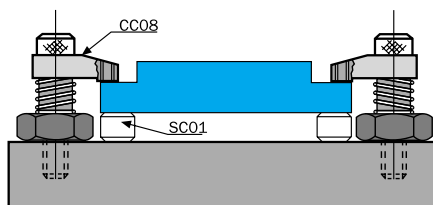
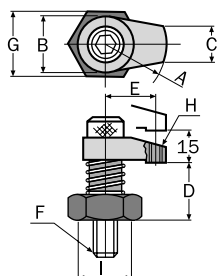

**Material:** Case Hardened Steel.  
**Hardness:** HRC 38 - 42.  
**Surface Finish:** Black Oxide.



| Product Number | Length x Width<br>A x B | Dimensions (mm) |    |    |     |    |     |    | Weight each | Order Code<br><b>IND-425</b> | List Price/1 | Offer Price/1 |
|----------------|-------------------------|-----------------|----|----|-----|----|-----|----|-------------|------------------------------|--------------|---------------|
|                |                         | C               | D  | E  | F   | G  | H   | I  |             |                              |              |               |
| CC080112       | 30 x 28mm               | 16              | 40 | -  | M12 | 29 | -   | 21 | 0.29kg      | <b>-1040D</b>                | £38.15       | <b>£35.10</b> |
| CC080212       | 50 x 32mm               | 20              | 45 | 40 | M12 | 36 | M12 | 26 | 0.50kg      | <b>-1040G</b>                | £45.15       | <b>£41.54</b> |
| CC080316       | 60 x 40mm               | 25              | 45 | 45 | M16 | 41 | M16 | 32 | 0.75kg      | <b>-1040J</b>                | £57.65       | <b>£53.04</b> |

**CC11 - Free Vice Jaw**

Clamping force in two directions, with serrated jaws for holding large or irregular shapes.

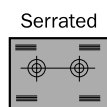
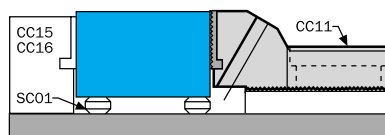
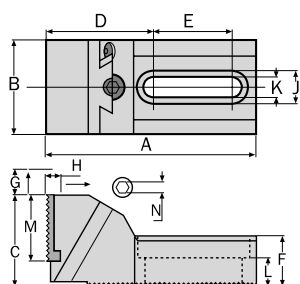

**Material:** Body: Grey Cast Iron.  
 Jaw: Medium Carbon Steel EN8D.  
**Hardness:** Jaw Only: HRC 45 - 48.  
**Surface Finish:** Jaw: Black Oxide.



| Product Number | Type     | Length x Width<br>A x B | Dimensions (mm) |    |    |    |    |   |    |    |      |    |    | Weight each | Order Code<br><b>IND-425</b> | List Price/1 | Offer Price/1  |
|----------------|----------|-------------------------|-----------------|----|----|----|----|---|----|----|------|----|----|-------------|------------------------------|--------------|----------------|
|                |          |                         | C               | D  | E  | F  | G  | H | J  | K  | L    | M  | N  |             |                              |              |                |
| CC110112       | Serrated | 133 x 60mm              | 54.5            | 68 | 50 | 32 | 16 | 6 | 22 | 13 | 16.8 | 42 | 10 | 2.0kg       | <b>-1045D</b>                | £214.00      | <b>£196.88</b> |

**CC12 - Adjustable Clamp**

Low profile clamp that keeps top surfaces clear for machining. Ideal for rough or finished parts.

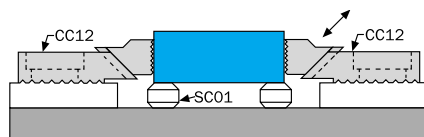
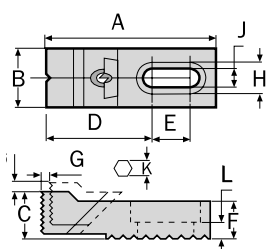

**Material:** Medium Carbon Steel.  
**Hardness:** Jaw Only: HRC 38.  
**Surface Finish:** Black Oxide.  
**Jaws:** Surface treated with high frequency quenching.



| Product Number | Type     | Length x Width x Height<br>A x B x C | Dimensions (mm) |      |    |    |    |      |   |    | Weight each | Order Code<br><b>IND-425</b> | List Price/1 | Offer Price/1 |
|----------------|----------|--------------------------------------|-----------------|------|----|----|----|------|---|----|-------------|------------------------------|--------------|---------------|
|                |          |                                      | D               | E    | F  | G  | H  | J    | K | L  |             |                              |              |               |
| CC120108       | Serrated | 73.45 x 25 x 18mm                    | 46.95           | 16.5 | 16 | 7  | 14 | 8.5  | 4 | 7  | 0.18kg      | <b>-1050D</b>                | £60.58       | <b>£55.73</b> |
| CC120212       |          | 106.64 x 35 x 27.5mm                 | 62.14           | 30.0 | 22 | 12 | 20 | 13.5 | 6 | 9  | 0.52kg      | <b>-1050F</b>                | £71.98       | <b>£66.22</b> |
| CC120316       |          | 134.64 x 40 x 37.5mm                 | 82.14           | 35.0 | 30 | 14 | 26 | 17.0 | 8 | 13 | 1.02kg      | <b>-1050H</b>                | £90.96       | <b>£83.68</b> |
| CC120408       | Ground   | 72.00 x 25 x 20.0mm                  | 45.00           | 16.0 | 16 | 7  | 14 | 8.5  | 4 | 7  | 0.16kg      | <b>-1050J</b>                | £58.02       | <b>£53.38</b> |
| CC120512       |          | 104.64 x 35 x 27.5mm                 | 62.14           | 30.0 | 22 | 12 | 20 | 13.5 | 6 | 9  | 0.52kg      | <b>-1050M</b>                | £68.67       | <b>£63.18</b> |
| CC120616       |          | 134.64 x 40 x 37.5mm                 | 82.14           | 35.0 | 30 | 14 | 26 | 17.0 | 8 | 13 | 1.02kg      | <b>-1050R</b>                | £87.47       | <b>£80.47</b> |

**CONTRACT PRICES AVAILABLE FOR VOLUME PURCHASES**

All Prices Exclude V.A.T. © 2011

Workshop Equipment

**INDEXA** CC13 - Adjustable Stepped Clamp

Low profile clamp for holding thin parts and keeping top surfaces clear for machining.

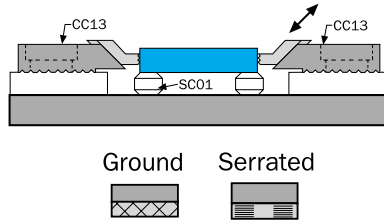
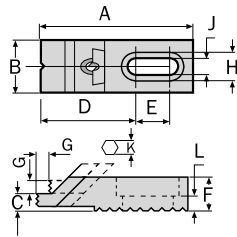

**Material:** Medium Carbon Steel.  
**Heat Treated To:** HRC 38.  
**Surface Finish:** Black Oxide.  
**Jaws:** Surface treated with high frequency quenching.



| Product Number | Type     | Length x Width x Height<br>A x B x C | Dimensions (mm) |      |      |    |    |      |   |    | Weight each | Order Code<br>IND-425 | List Price/1 | Offer Price/1 |
|----------------|----------|--------------------------------------|-----------------|------|------|----|----|------|---|----|-------------|-----------------------|--------------|---------------|
|                |          |                                      | D               | E    | F    | G  | H  | J    | K | L  |             |                       |              |               |
| CC130108       | Serrated | 73.45 x 25 x 18mm                    | 46.95           | 16.5 | 16.5 | 7  | 14 | 8.5  | 5 | 7  | 0.18kg      | -1055D                | £53.93       | £49.62        |
| CC130212       |          | 106.64 x 35 x 27.5mm                 | 64.14           | 30.0 | 22.0 | 12 | 20 | 13.5 | 6 | 9  | 0.52kg      | -1055F                | £60.96       | £56.08        |
| CC130316       | Ground   | 133.14 x 40 x 14mm                   | 90.00           | 30.0 | 30.0 | 14 | 26 | 17.0 | 8 | 13 | 0.85kg      | -1055H                | £83.25       | £76.59        |
| CC130512       |          | 105 x 35 x 27.5mm                    | 64.14           | 26.0 | 22.0 | 12 | 20 | 13.5 | 6 | 9  | 0.52kg      | -1055M                | £61.73       | £56.79        |

**CC18 - Plate Clamp**

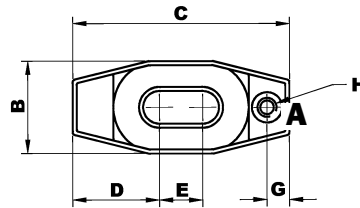
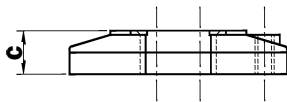

**Material:** Medium Carbon Steel.  
**Surface Finish:** Manganese Phosphate.



\* Supplied with T-Slot bolt, flanged nut and catch bolt

| Product Number | Length x Width<br>A x B | Dimensions (mm) |      |    |    |    |     | Weight each | Order Code<br>IND-425 | List Price/1 | Offer Price/1 |
|----------------|-------------------------|-----------------|------|----|----|----|-----|-------------|-----------------------|--------------|---------------|
|                |                         | C               | D    | E  | F  | G  | H   |             |                       |              |               |
| CC18PC-4       | 100 x 41mm              | 19              | 41.0 | 18 | 17 | 12 | M12 | 0.40kg      | -1080C                | £17.14       | £15.77        |

**CC19 - Forged Swivel Clamp**

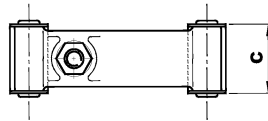
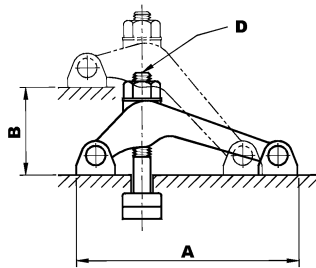

**Material:** Medium Carbon Steel/Steel Forging.  
**Heat Treated To:** 32 - 38°.  
**Surface Finish:** Black Oxide.



| Product Number | Length x Width<br>A x B | Dimensions (mm) |         | Weight each | Order Code<br>IND-425 | List Price/1 | Offer Price/1 |
|----------------|-------------------------|-----------------|---------|-------------|-----------------------|--------------|---------------|
|                |                         | C               | D       |             |                       |              |               |
| CC19-NC50      | 131 x 75mm              | 46.5            | M12-125 | 1.50kg      | -1085D                | £69.09       | £63.56        |

**CC20 - Forged Swivel Clamp**

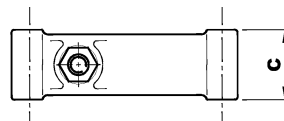
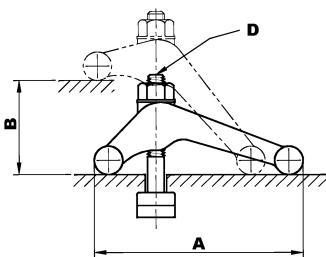

**Material:** Medium Carbon Steel/Steel Forging.  
**Heat Treated To:** 32 - 38°.  
**Surface Finish:** Black Oxide.

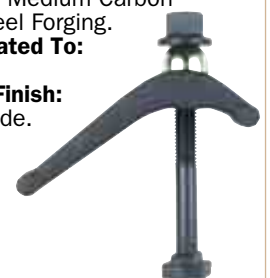

| Product Number | Length x Width<br>A x B | Dimensions (mm) |         | Weight each | Order Code<br>IND-425 | List Price/1 | Offer Price/1 |
|----------------|-------------------------|-----------------|---------|-------------|-----------------------|--------------|---------------|
|                |                         | C               | D       |             |                       |              |               |
| CC20-NC6       | 150 x 85mm              | 52              | M16-150 | 2.42kg      | -1090M                | £52.97       | £48.73        |
| CC20-NC8       | 194 x 105mm             | 58              | M20-175 | 4.50kg      | -1090T                | £74.76       | £68.78        |

**CC21 - Swivel Rack Clamp**

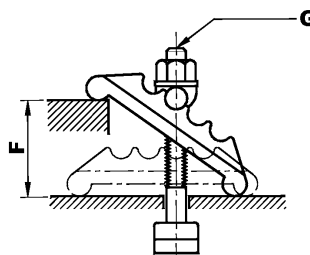
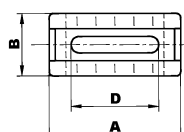
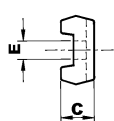

**Material:** Medium Carbon Steel/Steel Forging.  
**Surface Finish:** Black Oxide.



| Product Number | Length x Width<br>A x B | Dimensions (mm) |    |    |    |     | Weight each | Order Code<br>IND-425 | List Price/1 | Offer Price/1 |
|----------------|-------------------------|-----------------|----|----|----|-----|-------------|-----------------------|--------------|---------------|
|                |                         | C               | D  | E  | F  | G   |             |                       |              |               |
| CC21-0216      | 125 x 56mm              | 33              | 84 | 18 | 65 | M16 | 2.10kg      | -1095M                | £51.49       | £47.37        |

Workshop Equipment

**INDEXA** CC24 - Eccentric Cam Lock

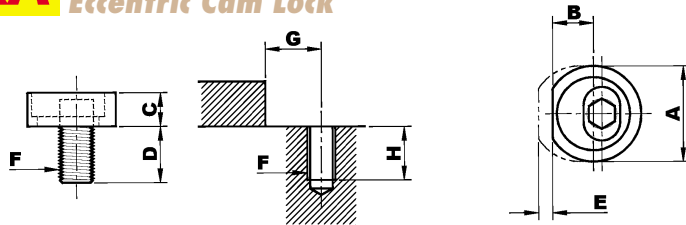

**Material:** Medium Carbon Steel.  
**Hardness:** HRC 35.  
**Surface Finish:** Black Oxide.



| Product Number | Dimensions (mm) |      |    |      |   |     |      |    | Weight each | Order Code<br><b>IND-425</b> | List Price/1 | Offer Price/1 |
|----------------|-----------------|------|----|------|---|-----|------|----|-------------|------------------------------|--------------|---------------|
|                | A               | B    | C  | D    | E | F   | G    | H  |             |                              |              |               |
| CC240210       | 26              | 11.8 | 8  | 14.3 | 4 | M10 | 12.5 | 22 | .03kg       | <b>-1110C</b>                | £13.70       | <b>£12.60</b> |
| CC240312       | 30              | 13.5 | 9  | 19   | 5 | M12 | 14.5 | 22 | .06kg       | <b>-1110G</b>                | £15.71       | <b>£14.45</b> |
| CC240416       | 38              | 16.0 | 12 | 23   | 6 | M16 | 17.5 | 26 | .12kg       | <b>-1110P</b>                | £17.65       | <b>£16.24</b> |

**CC25 - Step Clamp**

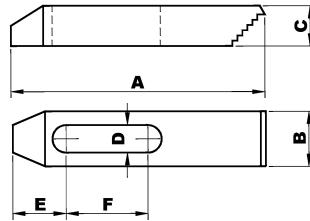

**Material:** Medium Carbon Steel.  
**Hardness:** HRC 32 - 38.  
**Surface Finish:** Black Oxide.



| Product Number | Length x Width<br>A x B | Dimensions (mm) |    |    |    | To Suit Stud Size | Weight each | Order Code<br><b>IND-425</b> | List Price/1 | Offer Price/1 |
|----------------|-------------------------|-----------------|----|----|----|-------------------|-------------|------------------------------|--------------|---------------|
|                |                         | C               | D  | E  | F  |                   |             |                              |              |               |
| CC251463       | 63 x 25mm               | 13              | 15 | 20 | 14 | M14               | 0.12kg      | <b>-1130C</b>                | £4.77        | <b>£4.39</b>  |
| CC2514100      | 100 x 32mm              | 19              | 15 | 29 | 34 | M14               | 0.38kg      | <b>-1130G</b>                | £7.26        | <b>£6.68</b>  |
| CC2514150      | 150 x 32mm              | 22              | 15 | 32 | 50 | M14               | 0.68kg      | <b>-1130J</b>                | £9.51        | <b>£8.75</b>  |
| CC2516100      | 100 x 32mm              | 19              | 17 | 31 | 26 | M16               | 0.42kg      | <b>-1135G</b>                | £5.74        | <b>£5.28</b>  |
| CC2516150      | 150 x 30mm              | 22              | 17 | 40 | 47 | M16               | 0.72kg      | <b>-1135J</b>                | £8.56        | <b>£7.88</b>  |

**ATLAS WORKHOLDERS** Step Clamp

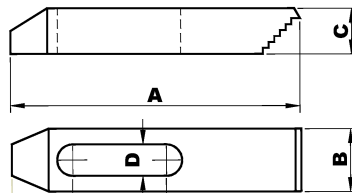

**Material:** Medium Carbon Steel.  
**Hardness:** HRC 32 - 38.  
**Surface Finish:** Black Oxide.



| Product Number | To Suit Stud Size        | Dimensions (mm) |    |    |               | Order Code<br><b>ATL-425</b> | List Price/1 | Offer Price/1 |
|----------------|--------------------------|-----------------|----|----|---------------|------------------------------|--------------|---------------|
|                |                          | A x B           | C  | D  | D             |                              |              |               |
| SC105222       |                          | 55 x 25         | 12 | 13 | <b>-2020K</b> | £4.72                        | <b>£4.25</b> |               |
| SC108825       | M10 <sup>3/8</sup> " UNC | 88 x 25         | 16 | 11 | <b>-2040K</b> | £7.19                        | <b>£6.47</b> |               |
| SC1012828      |                          | 128 x 28        | 19 | 11 | <b>-2060K</b> | £9.41                        | <b>£8.47</b> |               |
| SC126428       |                          | 64 x 28         | 12 | 13 | <b>-2120K</b> | £4.72                        | <b>£4.25</b> |               |
| SC1210032      | M12 <sup>1/2</sup> " UNC | 100 x 32        | 19 | 13 | <b>-2140K</b> | £7.19                        | <b>£6.47</b> |               |
| SC1215032      |                          | 150 x 32        | 22 | 13 | <b>-2160K</b> | £9.41                        | <b>£8.47</b> |               |

| Product Number | To Suit Stud Size        | Dimensions (mm) |    |    |               | Order Code<br><b>ATL-425</b> | List Price/1 | Offer Price/1 |
|----------------|--------------------------|-----------------|----|----|---------------|------------------------------|--------------|---------------|
|                |                          | A x B           | C  | D  | D             |                              |              |               |
| SC146428       |                          | 64 x 28         | 12 | 15 | <b>-2220K</b> | £4.72                        | <b>£4.25</b> |               |
| SC1410035      | M14                      | 100 x 35        | 19 | 15 | <b>-2240K</b> | £7.19                        | <b>£6.47</b> |               |
| SC1415032      |                          | 150 x 32        | 22 | 15 | <b>-2260K</b> | £9.41                        | <b>£8.47</b> |               |
| SC166432       |                          | 64 x 32         | 12 | 17 | <b>-2420K</b> | £4.72                        | <b>£4.25</b> |               |
| SC1610038      | M16 <sup>5/8</sup> " UNC | 100 x 38        | 20 | 17 | <b>-2440K</b> | £7.19                        | <b>£6.47</b> |               |
| SC1615038      |                          | 150 x 38        | 22 | 17 | <b>-2460K</b> | £9.41                        | <b>£8.47</b> |               |

**INDEXA** FC01 - Plain Ball End

Precision swivel ball that can be used either as a contact bolt or rest pad. As contact pads these swivel ball units are ideal for evenly distributing clamping pressure on sloped or uneven surfaces.

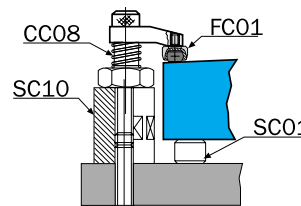
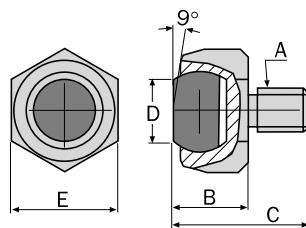

**Material:**  
Body - Medium Carbon Steel.  
Ball - Through Hardened Steel  
**EN 31.**  
**Hardness:**  
Bolt - HRC 35.  
Ball - HRC 62.  
**Surface Finish:**  
Black Oxide.



| Product Number | Thread<br>A | Dimensions (mm) |    |    |    | Weight each | Order Code<br><b>IND-425</b> | List Price/1 | Offer Price/1 |
|----------------|-------------|-----------------|----|----|----|-------------|------------------------------|--------------|---------------|
|                |             | B               | C  | D  | E  |             |                              |              |               |
| FC010216       | M16 x 2.00  | 26              | 42 | 14 | 27 | 0.14kg      | <b>-2010R</b>                | £22.50       | <b>£20.70</b> |

**FC02 - Seratted Ball End**

Precision swivel ball that can be used either as a contact bolt or rest pad. As contact pads these swivel ball units are ideal for evenly distributing clamping pressure on sloped or uneven surfaces.

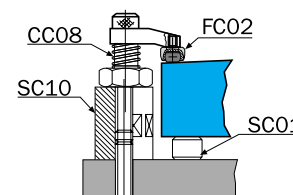
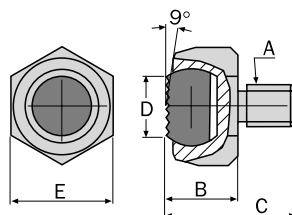

**Material:**  
Body - Medium Carbon Steel.  
Ball - Through Hardened Steel  
**EN 31.**  
**Hardness:**  
Bolt - HRC 35.  
Ball - HRC 62.  
**Surface Finish:**  
Black Oxide.



| Product Number | Thread<br>A | Dimensions (mm) |    |    |    | Weight each | Order Code<br><b>IND-425</b> | List Price/1 | Offer Price/1 |
|----------------|-------------|-----------------|----|----|----|-------------|------------------------------|--------------|---------------|
|                |             | B               | C  | D  | E  |             |                              |              |               |
| FC010112       | M12 x 1.75  | 22              | 35 | 12 | 22 | 0.070kg     | <b>-2015J</b>                | £22.64       | <b>£20.83</b> |
| FC010216       | M16 x 2.00  | 26              | 42 | 14 | 27 | 0.14kg      | <b>-2015R</b>                | £30.05       | <b>£27.65</b> |

**CONTRACT PRICES AVAILABLE FOR VOLUME PURCHASES**

All Prices Exclude V.A.T. © 2011

Workshop Equipment

**INDEXA** FC03 - Knurled Nut

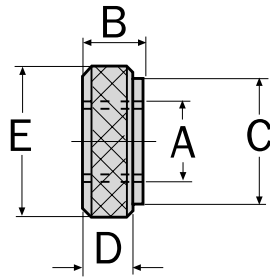

**Material:** Medium Carbon Steel.  
**Hardness:** HRC 30 - 35.  
**Surface Finish:** Black Oxide.



| Product Number | Thread A | Dimensions (mm) |    |    |    | Weight each | Order Code IND-425 | List Price/1 | Offer Price/1 |
|----------------|----------|-----------------|----|----|----|-------------|--------------------|--------------|---------------|
|                |          | B               | C  | D  | E  |             |                    |              |               |
| FC030210       | M10      | 10              | 20 | 8  | 25 | 0.030kg     | -2020K             | £5.13        | £4.72         |
| FC030312       | M12      | 12              | 24 | 10 | 28 | 0.040kg     | -2020M             | £5.73        | £5.27         |
| FC030416       | M16      | 12              | 25 | 10 | 30 | 0.045kg     | -2020R             | £6.57        | £6.04         |

**FC04 - Flanged Nut**

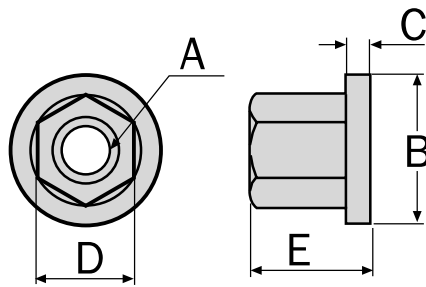

**Material:** Medium Carbon Steel.  
**Hardness:** HRC 30 - 35.  
**Surface Finish:** Black Oxide.



| Product Number | Thread A | Dimensions (mm) |   |    |    | Weight each | Order Code IND-425 | List Price/1 | Offer Price/1 |
|----------------|----------|-----------------|---|----|----|-------------|--------------------|--------------|---------------|
|                |          | B               | C | D  | E  |             |                    |              |               |
| FC040110       | M10      | 22              | 3 | 17 | 13 | 0.020kg     | -2025G             | £2.34        | £2.15         |
| FC040212       | M12      | 28              | 4 | 19 | 17 | 0.040kg     | -2025K             | £2.95        | £2.71         |
| FC040214       | M14      | 28              | 4 | 22 | 17 | 0.040kg     | -2025M             | £3.73        | £3.43         |
| FC040316       | M16      | 33              | 5 | 24 | 20 | 0.060kg     | -2025P             | £3.73        | £3.43         |
| FC040420       | M20      | 40              | 6 | 30 | 25 | 0.110kg     | -2025T             | £6.80        | £6.26         |

**FC05 - Extension Nut**

Extends the length of clamping studs.

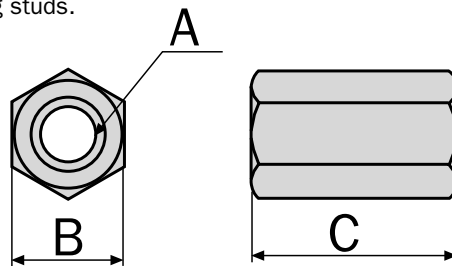

**Material:** Medium Carbon Steel.  
**Hardness:** HRC 30 - 35.  
**Surface Finish:** Black Oxide.



| Product Number | Size A | Dimensions (mm) |    | Weight each | Order Code IND-425 | List Price/1 | Offer Price/1 |
|----------------|--------|-----------------|----|-------------|--------------------|--------------|---------------|
|                |        | B               | C  |             |                    |              |               |
| FC050110       | M10    | 17              | 30 | 0.030kg     | -2030F             | £2.33        | £2.14         |
| FC050212       | M12    | 19              | 36 | 0.046kg     | -2030K             | £2.31        | £2.13         |
| FC050314       | M14    | 22              | 42 | 0.065kg     | -2030M             | £7.33        | £6.74         |
| FC050316       | M16    | 24              | 48 | 0.110kg     | -2030N             | £4.57        | £4.20         |
| FC050420       | M20    | 30              | 60 | 0.220kg     | -2030R             | £7.33        | £6.74         |

**FC06 - T-Slot Nut (Milled)**

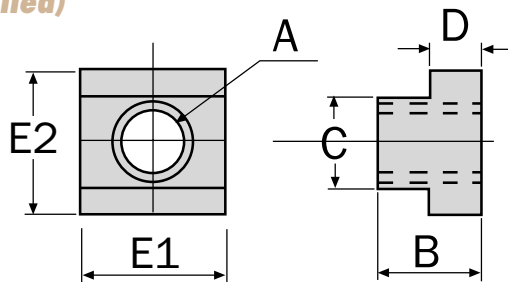

**Material:** Medium Carbon Steel.  
**Hardness:** HRC 30 - 35.  
**Surface Finish:** Black Oxide.



| Product Number | Size A | Dimensions (mm) |      |      |    |      | Weight each | Order Code IND-425 | List Price/1 | Offer Price/1 |
|----------------|--------|-----------------|------|------|----|------|-------------|--------------------|--------------|---------------|
|                |        | B               | C    | D    | E1 | E2   |             |                    |              |               |
| FC060110       | M10    | 14.0            | 11.8 | 7.0  | 22 | 18.0 | 0.022kg     | -2035G             | £2.17        | £2.00         |
| FC060212       | M12    | 16.0            | 13.8 | 8.0  | 28 | 22.0 | 0.048kg     | -2035K             | £2.36        | £2.17         |
| FC050314       | M14    | 16.0            | 15.8 | 8.0  | 28 | 25.0 | 0.057kg     | -2035M             | £3.68        | £3.39         |
| FC060316       | M16    | 20.0            | 17.7 | 10.5 | 30 | 28.5 | 0.085kg     | -2035P             | £3.68        | £3.39         |
| FC060420       | M20    | 25.0            | 22.0 | 14.0 | 38 | 36.0 | 0.190kg     | -2035T             | £5.69        | £5.23         |

**INDEXA** FC07 - Engineers Stud

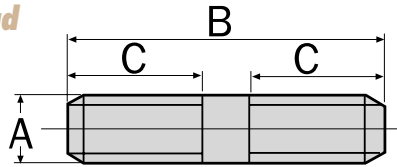

**Material:** Medium Carbon Steel.  
**Hardness:** HRC 30 - 35.  
**Surface Finish:** Black Oxide.



| Product Number | Size A x B  | Dimension C | Weight each | Order Code IND-425 | List Price/1 | Offer Price/1 |
|----------------|-------------|-------------|-------------|--------------------|--------------|---------------|
| FC070110       | M10 x 50mm  | 22          | 30g         | -2120S             | £0.92        | £0.85         |
| FC070210       | M10 x 75mm  | 30          | 42g         | -2125S             | £1.31        | £1.21         |
| FC070310       | M10 x 100mm | 38          | 55g         | -2130S             | £1.31        | £1.21         |
| FC070510       | M10 x 150mm | 50          | 90g         | -2140S             | £1.66        | £1.53         |
| FC070612       | M12 x 50mm  | 22          | 40g         | -2145S             | £1.31        | £1.21         |
| FC070712       | M12 x 75mm  | 30          | 60g         | -2150S             | £1.69        | £1.55         |
| FC070812       | M12 x 100mm | 38          | 80g         | -2155S             | £1.82        | £1.67         |
| FC070912       | M12 x 125mm | 38          | 100g        | -2160S             | £1.99        | £1.83         |
| FC071012       | M12 x 150mm | 50          | 125g        | -2165S             | £2.24        | £2.06         |
| FC071112       | M12 x 200mm | 65          | 160g        | -2170S             | £2.67        | £2.46         |
| FC071212       | M12 x 300mm | 80          | 240g        | -2175S             | £3.35        | £3.08         |
| FC071214       | M14 x 75mm  | 30          | 65g         | -2176S             | £2.24        | £2.06         |
| FC071214       | M14 x 100mm | 38          | 85g         | -2177A             | £2.59        | £2.38         |
| FC071214       | M14 x 125mm | 38          | 105g        | -2177G             | £2.94        | £2.70         |
| FC071214       | M14 x 150mm | 50          | 130g        | -2177K             | £3.55        | £3.27         |
| FC071214       | M14 x 200mm | 65          | 165g        | -2177T             | £4.37        | £4.02         |
| FC071316       | M16 x 75mm  | 20          | 120g        | -2180S             | £2.24        | £2.06         |
| FC071416       | M16 x 100mm | 38          | 145g        | -2185S             | £2.59        | £2.38         |
| FC071516       | M16 x 125mm | 38          | 180g        | -2190S             | £2.94        | £2.70         |
| FC071616       | M16 x 150mm | 50          | 230g        | -2195S             | £3.55        | £3.27         |
| FC071616       | M16 x 175mm | 50          | 240g        | -2197S             | £4.46        | £4.10         |
| FC071716       | M16 x 200mm | 65          | 290g        | -2200S             | £4.37        | £4.02         |
| FC071816       | M16 x 250mm | 65          | 350g        | -2205S             | £5.11        | £4.70         |
| FC071916       | M16 x 300mm | 80          | 450g        | -2210S             | £5.46        | £5.02         |
| FC072016       | M16 x 400mm | 100         | 580g        | -2215S             | £7.35        | £6.76         |
| FC072116       | M16 x 500mm | 100         | 700g        | -2220S             | £8.48        | £7.80         |
| FC072220       | M20 x 75mm  | 30          | 170g        | -2225S             | £2.94        | £2.70         |
| FC072320       | M20 x 100mm | 38          | 230g        | -2230S             | £3.35        | £3.08         |
| FC072420       | M20 x 125mm | 38          | 280g        | -2235S             | £4.07        | £3.74         |
| FC072520       | M20 x 150mm | 50          | 360g        | -2240S             | £4.83        | £4.44         |
| FC072620       | M20 x 200mm | 65          | 450g        | -2245S             | £5.97        | £5.49         |
| FC072720       | M20 x 250mm | 65          | 550g        | -2250S             | £7.35        | £6.76         |
| FC072820       | M20 x 300mm | 80          | 700g        | -2255S             | £7.86        | £7.23         |
| FC072920       | M20 x 400mm | 100         | 880g        | -2260S             | £10.36       | £9.53         |
| FC073020       | M20 x 500mm | 100         | 1100g       | -2265S             | £11.28       | £10.38        |

**FC08 - T-Slot Nut (Ground)**

Ground surfaces provide accurate positioning inside of T-slot.

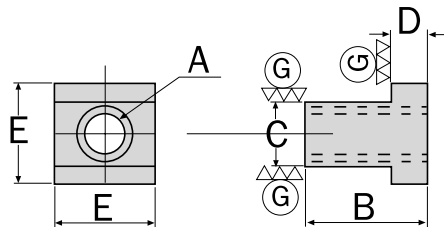

| Product Number | Thread | Dimensions (mm) |    |        |    |     | Weight each | Order Code IND-425 | List Price/1 | Offer Price/1 |
|----------------|--------|-----------------|----|--------|----|-----|-------------|--------------------|--------------|---------------|
|                |        | A               | B  | C (h6) | D  | E   |             |                    |              |               |
| FC008112       | M12    | 22              | 14 | 8      | 22 | 45g | -2505J      | £12.58             | £11.57       |               |
| FC008216       | M16    | 30              | 18 | 10     | 28 | 80g | -2505R      | £15.20             | £13.98       |               |

**Material:** Medium Carbon Steel.  
**Hardness:** HRC 30 - 35.



**FC09 - Swing Bolt**

Reamed hole for smooth swiveling.

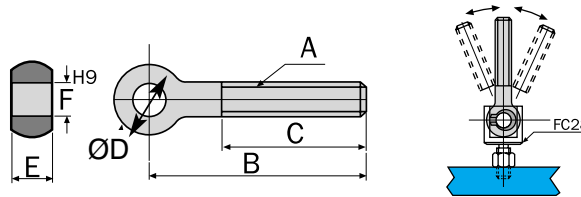

| Product Number | Size A x B  | Dimensions (mm) |    |    |    |      | Weight each | Order Code IND-425 | List Price/1 | Offer Price/1 |
|----------------|-------------|-----------------|----|----|----|------|-------------|--------------------|--------------|---------------|
|                |             | C               | D  | E  | F  | H9   |             |                    |              |               |
| FC040110       | M10 x 75mm  | 40              | 20 | 12 | 10 | 60g  | -2510E      | £13.65             | £12.56       |               |
| FC090210       | M10 x 100mm | 40              | 20 | 12 | 10 | 80g  | -2510H      | £17.78             | £16.36       |               |
| FC090412       | M12 x 100mm | 60              | 25 | 14 | 12 | 120g | -2510N      | £20.26             | £18.64       |               |
| FC090516       | M16 x 125mm | 60              | 32 | 17 | 16 | 250g | -2510P      | £23.70             | £21.80       |               |
| FC090616       | M16 x 150mm | 75              | 32 | 17 | 16 | 300g | -2510R      | £23.83             | £21.92       |               |

**Material:** Medium Carbon Steel.  
**Hardness:** HRC 30 - 35.



**FC11 - Internal Threaded Dowel**

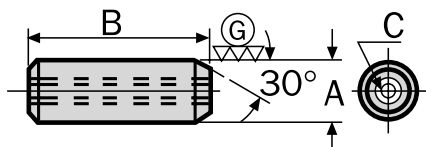

| Product Number | Size A (h6) x B | Threaded C | Weight each | Order Code IND-425 | List Price/1 | Offer Price/1 |
|----------------|-----------------|------------|-------------|--------------------|--------------|---------------|
|                |                 |            |             |                    |              |               |
| FC110210       | 10 x 30mm       | M5         | 15g         | -2520H             | £2.68        | £2.47         |
| FC110312       | 12 x 34mm       | M6         | 30g         | -2520K             | £3.52        | £3.24         |

**Material:** Medium Carbon Steel  
**EN19B.**  
**Hardness:** HRC 55 - 58.



**INDEXA** FC15 - Domed Rest Nut

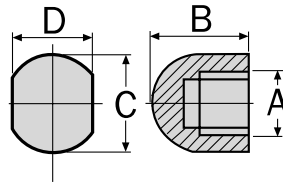

**Material:** Case Hardened Steel EN19A.  
**Hardness:** HRC 60.  
**Surface Finish:** Black Oxide.



| Product Number | Thread A | Dimensions (mm) |    |    |     | Weight each       | Order Code | List Price/1 | Offer Price/1 |
|----------------|----------|-----------------|----|----|-----|-------------------|------------|--------------|---------------|
|                |          | B               | C  | D  |     |                   |            |              |               |
| FC150112       | M12      | 20              | 22 | 19 | 42g | IND-425<br>-2540J | £6.63      | £6.10        |               |
| FC150216       | M16      | 25              | 28 | 24 | 63g | IND-425<br>-2540R | £6.63      | £6.10        |               |

**FC16 - Swivel Clamping Screw**

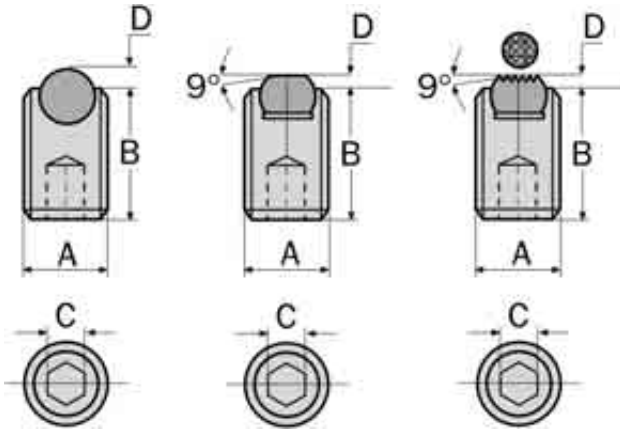

**Material:** Body - Medium Carbon Steel EN198.  
 Point - Through Hardened Steel EN 31.  
**Hardness:** Body - HRC 32 - 38.  
 Point - HRC 62.  
**Surface Finish:** Point - Hardened and Ground.



**Ball Point Dog Point Serrated Point**

| Ball Point      |    |        |          | Dog Point |            |         |         | Serrated Point |     |            |         |         |          |     |            |         |         |   |
|-----------------|----|--------|----------|-----------|------------|---------|---------|----------------|-----|------------|---------|---------|----------|-----|------------|---------|---------|---|
| Thread x Length | mm | Weight | Product  | mm        | Order Code | List    | Offer   | Product        | mm  | Order Code | List    | Offer   | Product  | mm  | Order Code | List    | Offer   |   |
| A x B           | C  | each   | Number   | D         | IND-425    | Price/1 | Price/1 | Number         | D   | IND-425    | Price/1 | Price/1 | Number   | D   | IND-425    | Price/1 | Price/1 |   |
| M6 x 15mm       | 3  | 2.4g   | FC160206 | 1.4       | -2610H     | £2.34   | £2.15   | -              | -   | -          | -       | -       | -        | -   | -          | -       | -       | - |
| M6 x 25mm       | 3  | 3.8g   | FC160306 | 1.4       | -2610N     | £2.47   | £2.27   | -              | -   | -          | -       | -       | -        | -   | -          | -       | -       | - |
| M8 x 12mm       | 4  | 3.2g   | FC160408 | 1.9       | -2615D     | £2.47   | £2.27   | FC162208       | 0.6 | -2645D     | £4.55   | £4.19   | -        | -   | -          | -       | -       | - |
| M8 x 20mm       | 4  | 5.8g   | FC160508 | 1.9       | -2615H     | £2.47   | £2.27   | FC162308       | 0.6 | -2645H     | £4.67   | £4.30   | -        | -   | -          | -       | -       | - |
| M8 x 30mm       | 4  | 9.0g   | FC160608 | 1.9       | -2615N     | £2.56   | £2.36   | -              | -   | -          | -       | -       | -        | -   | -          | -       | -       | - |
| M10 x 15mm      | 5  | 6.7g   | FC160710 | 2.4       | -2620D     | £2.47   | £2.27   | -              | -   | -          | -       | -       | -        | -   | -          | -       | -       | - |
| M10 x 25mm      | 5  | 11.2g  | FC160810 | 2.4       | -2620H     | £2.74   | £2.52   | FC162610       | 0.7 | -2650H     | £5.99   | £5.51   | -        | -   | -          | -       | -       | - |
| M10 x 35mm      | 5  | 16.2g  | -        | -         | -          | -       | -       | FC162710       | 0.7 | -2650N     | £6.10   | £5.61   | -        | -   | -          | -       | -       | - |
| M12 x 30mm      | 6  | 20.0g  | -        | -         | -          | -       | -       | FC162912       | 0.9 | -2655H     | £8.18   | £7.53   | -        | -   | -          | -       | -       | - |
| M12 x 50mm      | 6  | 40.0g  | FC161312 | 2.9       | -2625T     | £4.36   | £4.01   | -              | -   | -          | -       | -       | -        | -   | -          | -       | -       | - |
| M16 x 55mm      | 8  | 55.0g  | -        | -         | -          | -       | -       | FC163516       | 1.0 | -2660R     | £12.98  | £11.94  | -        | -   | -          | -       | -       | - |
| M16 x 65mm      | 8  | 65.0g  | -        | -         | -          | -       | -       | -              | -   | -          | -       | -       | FC165416 | 1.0 | -2690T     | £13.49  | £12.41  | - |

**FC17 - Swivel Shoulder Clamping Screw**

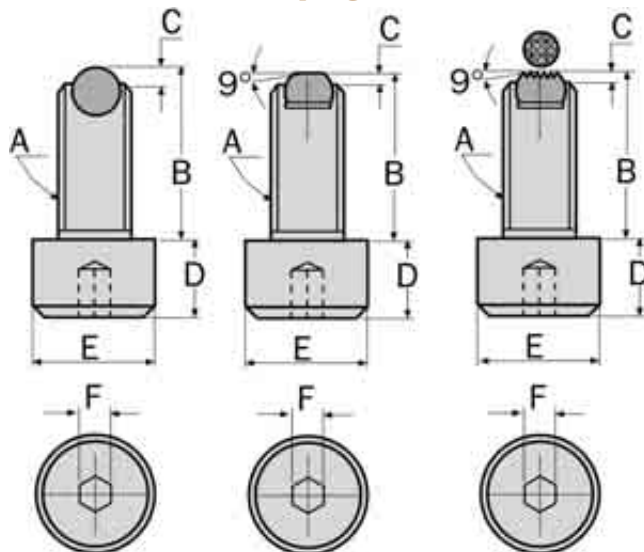

**Material:** Body - Medium Carbon Steel EN198.  
 Point - Through Hardened Steel EN 31.  
**Hardness:** Body - HRC 32 - 38.  
 Point - HRC 62.  
**Surface Finish:** Point - Hardened and Ground.



**Ball Point Dog Point Serrated Point**

| Ball Point |            |        |          | Dog Point |            |         |         | Serrated Point |     |            |         |         |          |     |            |         |         |
|------------|------------|--------|----------|-----------|------------|---------|---------|----------------|-----|------------|---------|---------|----------|-----|------------|---------|---------|
| Thread x L | Dimensions | Weight | Product  | mm        | Order Code | List    | Offer   | Product        | mm  | Order Code | List    | Offer   | Product  | mm  | Order Code | List    | Offer   |
| A x B (mm) | D E F      | each   | Number   | C         | IND-425    | Price/1 | Price/1 | Number         | C   | IND-425    | Price/1 | Price/1 | Number   | C   | IND-425    | Price/1 | Price/1 |
| M6 x 25    | 6 10 5     | 7.4g   | -        | -         | -          | -       | -       | -              | -   | -          | -       | -       | FC173606 | 0.5 | -2770H     | £6.36   | £5.85   |
| M8 x 40    | 8 13 6     | 24g    | FC170608 | 1.9       | -2725N     | £2.51   | £2.31   | -              | -   | -          | -       | -       | -        | -   | -          | -       | -       |
| M12 x 30   | 12 18 10   | 40g    | -        | -         | -          | -       | -       | FC172712       | 0.9 | -2760D     | £8.43   | £7.76   | -        | -   | -          | -       | -       |
| M12 x 45   | 12 18 10   | 50g    | -        | -         | -          | -       | -       | FC172812       | 0.9 | -2760H     | £8.96   | £8.24   | FC174512 | 0.9 | -2785H     | £13.25  | £12.19  |
| M12 x 65   | 12 18 10   | 70g    | FC171212 | 2.9       | -2735N     | £4.76   | £4.38   | FC172912       | 0.9 | -2760N     | £9.61   | £8.84   | -        | -   | -          | -       | -       |
| M12 x 80   | 12 18 10   | 83g    | -        | -         | -          | -       | -       | FC173012       | 0.9 | -2760R     | £9.74   | £8.96   | FC174712 | 0.9 | -2785R     | £13.91  | £12.80  |
| M16 x 40   | 16 24 14   | 90g    | FC171416 | 4.0       | -2740D     | £5.15   | £4.74   | FC173116       | 1.0 | -2765D     | £10.64  | £9.79   | -        | -   | -          | -       | -       |
| M16 x 50   | 16 24 14   | 110g   | -        | -         | -          | -       | -       | FC173216       | 1.0 | -2765H     | £11.05  | £10.17  | -        | -   | -          | -       | -       |
| M16 x 65   | 16 24 14   | 130g   | -        | -         | -          | -       | -       | FC173316       | 1.0 | -2765N     | £10.13  | £9.32   | -        | -   | -          | -       | -       |

Workshop Equipment

**INDEXA** FC18 - Grip Point Screw

Multipurpose work support and clamping unit, ideal for rough parts.

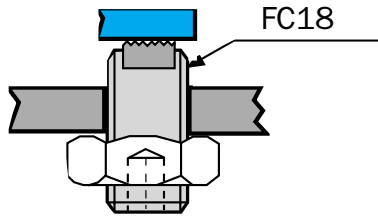
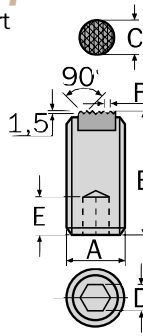

**Material:** Medium Carbon Steel EN19B.  
**Hardness:** HRC 32 - 38.  
Tooth plate HRC 60.  
**Serrated Surface:** Induction Hardened.  
**Surface Finish:** Black Oxide.



| Product Number | Thread x Length<br>A x B | Dimensions (mm) |   |   |     | Weight each |
|----------------|--------------------------|-----------------|---|---|-----|-------------|
|                |                          | C               | D | E | F   |             |
| FC180110       | M10 x 25mm               | 6.5             | 5 | 4 | 2.3 | 15g         |
| FC180616       | M16 x 50mm               | 11.5            | 8 | 6 | 3.0 | 78g         |

| Order Code | List Price/1 | Offer Price/1 |
|------------|--------------|---------------|
| IND-425    |              |               |
| -2825D     | £4.13        | £3.80         |
| -2825R     | £4.68        | £4.31         |

**FC19 - Grip Head Screw**

Multipurpose work support and clamping unit, ideal for rough parts.

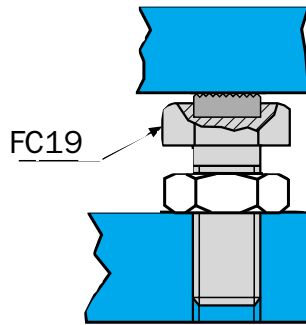
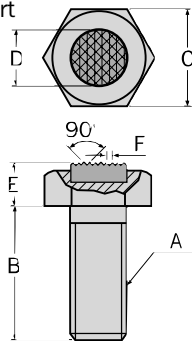

**Material:** Medium Carbon Steel EN19B.  
**Hardness:** HRC 32 - 38.  
Tooth plate HRC 60.



**Serrated Surface:** Induction Hardened.  
**Surface Finish:** Black Oxide.

| Product Number | Thread x Length<br>A x B | Dimensions (mm) |      |      |     | Weight each |
|----------------|--------------------------|-----------------|------|------|-----|-------------|
|                |                          | C               | D    | E    | F   |             |
| FC190106       | M6 x 25mm                | 10              | 7.9  | 6.0  | 2.3 | 8g          |
| FC190208       | M8 x 25mm                | 13              | 9.5  | 7.3  | 3.0 | 15g         |
| FC190310       | M10 x 25mm               | 17              | 12.7 | 8.4  | 3.0 | 30g         |
| FC190512       | M12 x 25mm               | 19              | 15.9 | 9.5  | 3.0 | 35g         |
| FC190816       | M16 x 50mm               | 24              | 19.1 | 12.0 | 3.0 | 100g        |

| Order Code | List Price/1 | Offer Price/1 |
|------------|--------------|---------------|
| IND-425    |              |               |
| -2830D     | £3.85        | £3.54         |
| -2830G     | £3.81        | £3.51         |
| -2830J     | £3.95        | £3.63         |
| -2830N     | £4.12        | £3.79         |
| -2830T     | £5.51        | £5.07         |

**FC20 - Rectangular Grip Pad**

Multipurpose work support and clamping unit, ideal for rough parts.

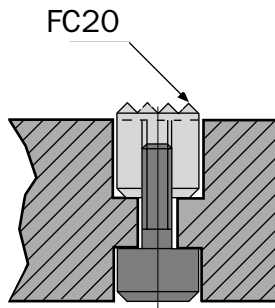
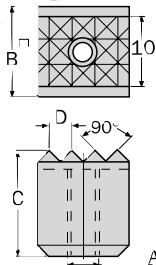

**Material:** High Tensile Steel EN16M.  
**Hardness:** HRC 60.  
**Serrated Surface:** Induction Hardened.  
**Surface Finish:** Black Oxide.



| Product Number | Thread x Length<br>A x B | Dimensions (mm) |     | Weight each |
|----------------|--------------------------|-----------------|-----|-------------|
|                |                          | C               | D   |             |
| FC200212       | M6 x 12mm                | 10              | 3.0 | 10g         |
| FC200320       | M6 x 20mm                | 10              | 3.0 | 30g         |
| FC200425       | M6 x 25mm                | 10              | 3.0 | 48g         |

| Order Code | List Price/1 | Offer Price/1 |
|------------|--------------|---------------|
| IND-425    |              |               |
| -2835G     | £4.51        | £4.15         |
| -2835L     | £5.32        | £4.89         |
| -2835P     | £5.32        | £4.89         |

**FC21 - Round Grip Pad**

Multipurpose work support and clamping unit, ideal for rough parts.

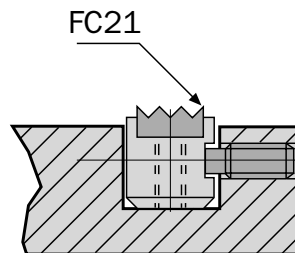
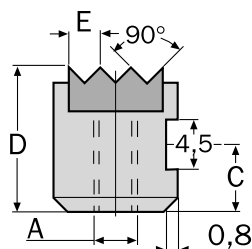
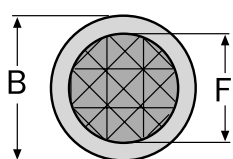

**Material:** Hardened Steel EN16M.  
**Hardness:** HRC 60.  
**Surface Finish:** Black Oxide.



| Product Number | Thread x Dia<br>A x B | Dimensions (mm) |    |     |      | Weight each |
|----------------|-----------------------|-----------------|----|-----|------|-------------|
|                |                       | C               | D  | E   | F    |             |
| FC210110       | M5 x 10mm             | 3.4             | 10 | 2.3 | 8.1  | 5g          |
| FC210212       | M6 x 12mm             | 4.0             | 12 | 3.0 | 9.6  | 8g          |
| FC210525       | M6 x 25mm             | 4.0             | 12 | 3.0 | 19.5 | 40g         |

| Order Code | List Price/1 | Offer Price/1 |
|------------|--------------|---------------|
| IND-425    |              |               |
| -2840D     | £5.32        | £4.89         |
| -2840G     | £5.04        | £4.64         |
| -2840P     | £4.87        | £4.48         |

**INDEXA** FC22 - Spacer

For use with jig components for increasing height or extending length.

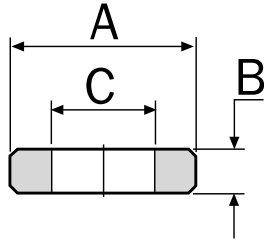

**Material:** Medium Carbon Steel.  
**Hardness:** HRC 40.



| Product Number | Dimensions (mm) |    |    | Weight each | Order Code        | List Price/1 | Offer Price/1 |
|----------------|-----------------|----|----|-------------|-------------------|--------------|---------------|
|                | A               | B  | C  |             |                   |              |               |
| FC220616       | 50              | 5  | 17 | 70g         | IND-425<br>-2845P | £7.26        | £6.68         |
| FC220716       | 50              | 10 | 17 | 350g        | -2845T            | £7.73        | £7.11         |

**FC23 - 'C' Washer**

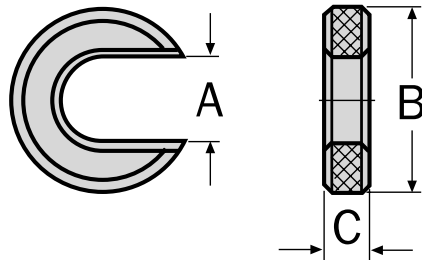

**Material:** Medium Carbon Steel.  
**Hardness:** HRC 40.  
**Surface Finish:** Black Oxide.



| Product Number | Dimensions (mm) |    |    | Weight each | Order Code        | List Price/1 | Offer Price/1 |
|----------------|-----------------|----|----|-------------|-------------------|--------------|---------------|
|                | A               | B  | C  |             |                   |              |               |
| CC010212       | 13              | 55 | 10 | 150g        | IND-425<br>-2850G | £7.42        | £6.83         |

**FC24 - Swing 'C' Washer**

Can be reversed to swing into position either clockwise or counter-clockwise.

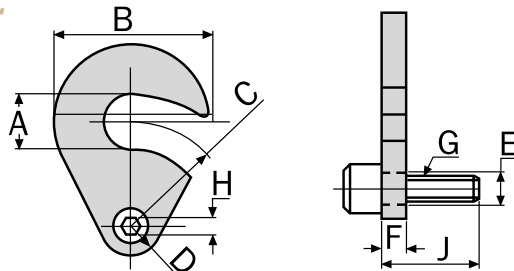

**Material:** Medium Carbon Steel.  
**Hardness:** HRC 40.  
**Surface Finish:** Black Oxide.



| Product Number | Dimensions (mm) |    |    |    |    |   |    |    |    | Weight each | Order Code        | List Price/1 | Offer Price/1 |
|----------------|-----------------|----|----|----|----|---|----|----|----|-------------|-------------------|--------------|---------------|
|                | A               | B  | C  | D  | E  | F | G  | H  | J  |             |                   |              |               |
| FC240212       | 13.5            | 40 | 27 | 20 | 10 | 8 | M8 | 10 | 20 | 90g         | IND-425<br>-2855G | £16.42       | £15.11        |

**FC25 - Spherical Washer Set**

2 piece washer set that compensates whenever a stud and clamping surface are not exactly perpendicular.

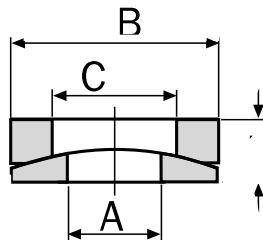

**Material:** Medium Carbon Steel.  
**Hardness:** HRC 38.  
**Surface Finish:** Black Oxide.



| Product Number | Dimensions (mm) |    |    |      | Weight each | Order Code        | List Price/1 | Offer Price/1 |
|----------------|-----------------|----|----|------|-------------|-------------------|--------------|---------------|
|                | A               | B  | C  | D    |             |                   |              |               |
| FC250112       | 13              | 26 | 15 | 7.5  | 20g         | IND-425<br>-2860D | £4.87        | £4.48         |
| FC250216       | 17              | 32 | 19 | 9.0  | 30g         | -2860G            | £7.12        | £6.55         |
| FC250320       | 21              | 40 | 23 | 12.0 | 50g         | -2860L            | £8.52        | £7.84         |

**FC29 - Swivel Foot**

Used for supporting uneven surfaces.

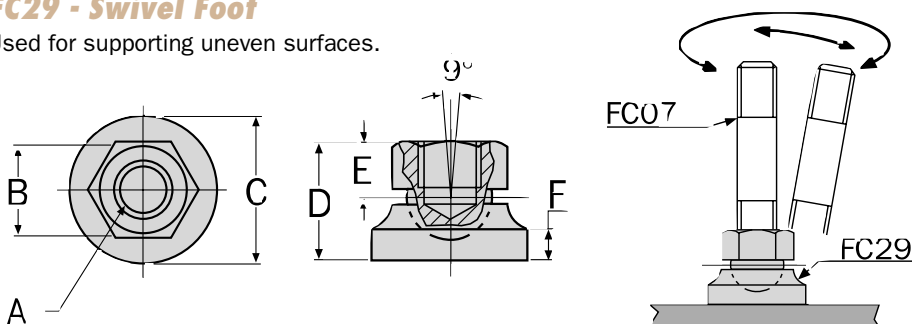

**Material:** Medium Carbon Steel.  
**Hardness:** HRC 32 - 38.  
**Surface Finish:** Black Oxide.



| Product Number | Size A | Dimensions (mm) |    |    |    |   | Weight each | Order Code        | List Price/1 | Offer Price/1 |
|----------------|--------|-----------------|----|----|----|---|-------------|-------------------|--------------|---------------|
|                |        | B               | C  | D  | E  | F |             |                   |              |               |
| FC290112       | M12    | 19              | 35 | 24 | 11 | 7 | 80g         | IND-425<br>-2870D | £13.06       | £12.02        |
| FC290216       | M16    | 24              | 40 | 29 | 13 | 8 | 150g        | -2870G            | £14.17       | £13.04        |

Workshop Equipment

**INDEXA** FC31 - Ground Dowel Bolt

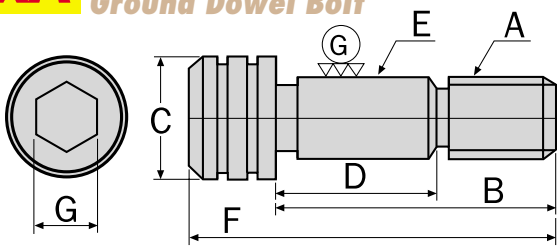

**Material:** Medium Carbon Steel EN19B.  
**Hardness:** HRC 32 - 38.



| Product Number | Diameter x Length<br>A x B | Dimensions (mm) |    |     |    |    | Weight each | Order Code<br>IND-425 | List Price/1 | Offer Price/1 |
|----------------|----------------------------|-----------------|----|-----|----|----|-------------|-----------------------|--------------|---------------|
|                |                            | C               | D  | E   | F  | G  |             |                       |              |               |
| FC310212       | M12 x 55mm                 | 18              | 33 | Ø12 | 67 | 10 | 60g         | -2880G                | £5.00        | £4.60         |
| FC310312       | M12 x 65mm                 | 18              | 43 | Ø12 | 77 | 10 | 70g         | -2880J                | £5.66        | £5.21         |
| FC310516       | M16 x 55mm                 | 24              | 30 | Ø16 | 72 | 14 | 120g        | -2880N                | £6.25        | £5.75         |
| FC310716       | M16 x 75mm                 | 24              | 50 | Ø16 | 92 | 14 | 150g        | -2880T                | £7.22        | £6.64         |

**FC32 - Centering Dowel**

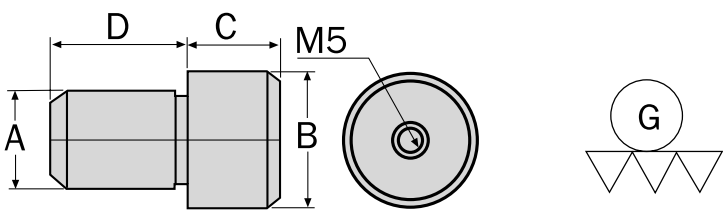

**Material:** Medium Carbon Steel EN19B.  
**Hardness:** HRC 55.



| Product Number | Size<br>A (h6) x B (h6) | Dimensions (mm) |    | Weight each | Order Code<br>IND-425 | List Price/1 | Offer Price/1 |
|----------------|-------------------------|-----------------|----|-------------|-----------------------|--------------|---------------|
|                |                         | C               | D  |             |                       |              |               |
| FC320525       | 18 x 25mm               | 17              | 25 | 98g         | -2885P                | £11.28       | £10.38        |

**FC33 - Knurled Nut**

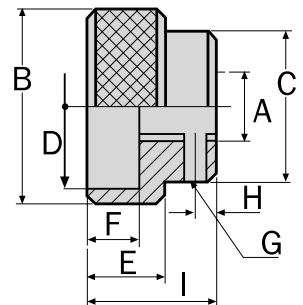

**Material:** Medium Carbon Steel.  
**Hardness:** HRC 32 - 38.  
**Surface Finish:** Black Oxide.



| Product Number | Thread<br>A | Dimensions (mm) |    |    |    |   |    |   | Weight each | Order Code<br>IND-425 | List Price/1 | Offer Price/1 |       |
|----------------|-------------|-----------------|----|----|----|---|----|---|-------------|-----------------------|--------------|---------------|-------|
|                |             | B               | C  | D  | E  | F | G  | H |             |                       |              |               | I     |
| FC330108       | M8          | 30              | 20 | 24 | 11 | 7 | M4 | 3 | 17          | 50g                   | -2890D       | £7.09         | £6.52 |

**FC40 - T-Slot Bolt**

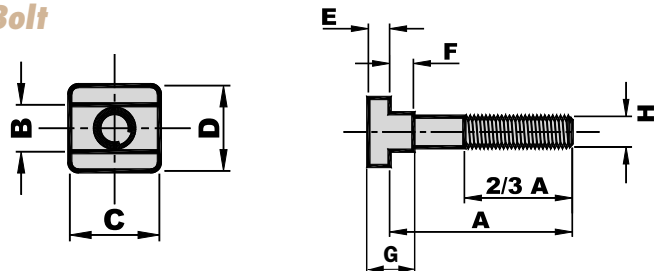

**Material:** Medium Carbon Steel.  
**Hardness:** HRC 32 - 38.  
**Surface Finish:** Black Oxide.



| Product Number | Dimensions (mm) |    |    |    |    |    |    |     | Weight each | Order Code<br>IND-425 | List Price/1 | Offer Price/1 |
|----------------|-----------------|----|----|----|----|----|----|-----|-------------|-----------------------|--------------|---------------|
|                | A               | B  | C  | D  | E  | F  | G  | H   |             |                       |              |               |
| FC40-1250      | 50              |    |    |    |    |    |    |     | 54g         | -2900D                | £5.63        | £5.18         |
| FC40-1275      | 75              |    |    |    |    |    |    |     | 57g         | -2900F                | £5.97        | £5.49         |
| FC40-12100     | 100             |    |    |    |    |    |    |     | 110g        | -2900H                | £6.42        | £5.91         |
| FC40-12125     | 125             | 12 | 26 | 22 | 7  | 6  | 13 | M12 | 125g        | -2900K                | £6.65        | £6.12         |
| FC40-12150     | 150             |    |    |    |    |    |    |     | 140g        | -2900M                | £7.79        | £7.17         |
| FC40-12175     | 175             |    |    |    |    |    |    |     | 170g        | -2900P                | £8.03        | £7.39         |
| FC40-12200     | 200             |    |    |    |    |    |    |     | 185g        | -2900R                | £8.96        | £8.24         |
| FC40-1650      | 50              |    |    |    |    |    |    |     | 130g        | -2910D                | £7.23        | £6.65         |
| FC40-1675      | 75              |    |    |    |    |    |    |     | 160g        | -2910F                | £7.69        | £7.07         |
| FC40-16100     | 100             |    |    |    |    |    |    |     | 200g        | -2910H                | £8.14        | £7.49         |
| FC40-16125     | 125             | 16 | 32 | 27 | 8  | 8  | 16 | M16 | 230g        | -2910K                | £8.83        | £8.12         |
| FC40-16150     | 150             |    |    |    |    |    |    |     | 270g        | -2910M                | £9.41        | £8.66         |
| FC40-16175     | 175             |    |    |    |    |    |    |     | 305g        | -2910P                | £10.32       | £9.49         |
| FC40-16200     | 200             |    |    |    |    |    |    |     | 325g        | -2910R                | £11.36       | £10.45        |
| FC40-2075      | 75              |    |    |    |    |    |    |     | 290g        | -2920F                | £11.48       | £10.56        |
| FC40-20100     | 100             |    |    |    |    |    |    |     | 350g        | -2920H                | £11.70       | £10.76        |
| FC40-20125     | 125             |    |    |    |    |    |    |     | 400g        | -2920K                | £11.93       | £10.98        |
| FC40-20150     | 150             | 20 | 40 | 30 | 11 | 11 | 22 | M20 | 455g        | -2920M                | £12.52       | £11.52        |
| FC40-20175     | 175             |    |    |    |    |    |    |     | 505g        | -2920P                | £13.08       | £12.03        |
| FC40-20200     | 200             |    |    |    |    |    |    |     | 560g        | -2920R                | £13.76       | £12.66        |
| FC40-24150     | 150             |    |    |    |    |    |    |     | 775g        | -2930M                | £14.24       | £13.10        |
| FC40-24200     | 200             | 24 | 50 | 44 | 16 | 15 | 31 | M24 | 925g        | -2930R                | £17.67       | £16.26        |

CONTRACT PRICES AVAILABLE FOR VOLUME PURCHASES

Workshop Equipment

**INDEXA** SC01 - Support Spacer



**Material:** Medium Carbon Steel.  
**Hardness:** HRC 40.  
**Surface Finish:** Black Oxide.

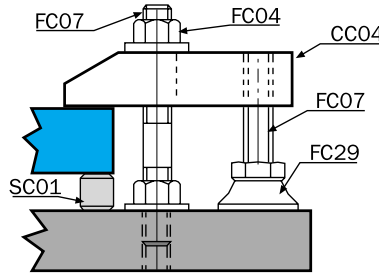
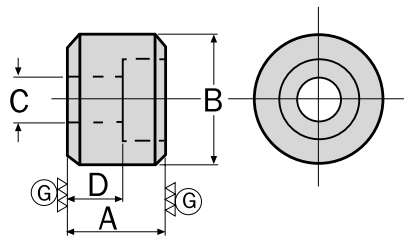

| Product Number | Height x Diameter A (±0.01) x B | Dimensions (mm) |    | Weight each | Order Code                      | List Price/1 | Offer Price/1 |
|----------------|---------------------------------|-----------------|----|-------------|---------------------------------|--------------|---------------|
|                |                                 | C               | D  |             |                                 |              |               |
| SC010112       | 30 x 40mm                       | M12             | 17 | 240g        | <b>IND-425</b><br><b>-3005D</b> | £12.11       | <b>£11.14</b> |

**SC04 - Location Collar**

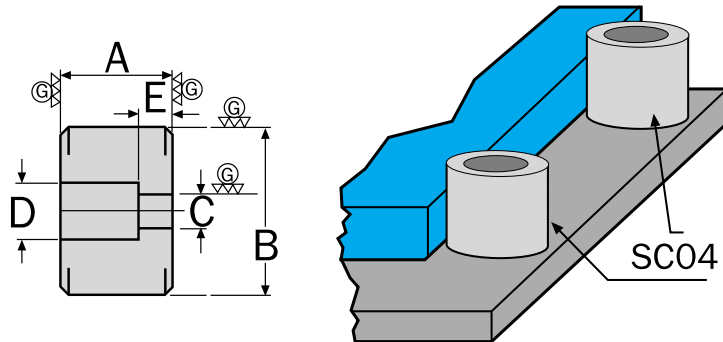

**Material:** Medium Carbon Steel.  
**Hardness:** HRC 40.  
**Surface Finish:** Black Oxide.



| Product Number | Height x Diameter A (±0.01) x B (±0.01) | Dimensions (mm) |      |    | Weight each | Order Code                      | List Price/1 | Offer Price/1 |
|----------------|---|-----------------|------|----|-------------|---------------------------------|--------------|---------------|
|                |   | C               | D    | E  |             |                                 |              |               |
| SC040112       | 30 x 40mm                               | ∅ 12            | ∅ 20 | 12 | 240g        | <b>IND-425</b><br><b>-3020D</b> | £20.67       | <b>£19.02</b> |
| SC040212       | 40 x 40mm                               | ∅ 12            | ∅ 20 | 12 | 320g        | <b>-3020F</b>                   | £21.32       | <b>£19.61</b> |

**SC10 - Extension Pillar**

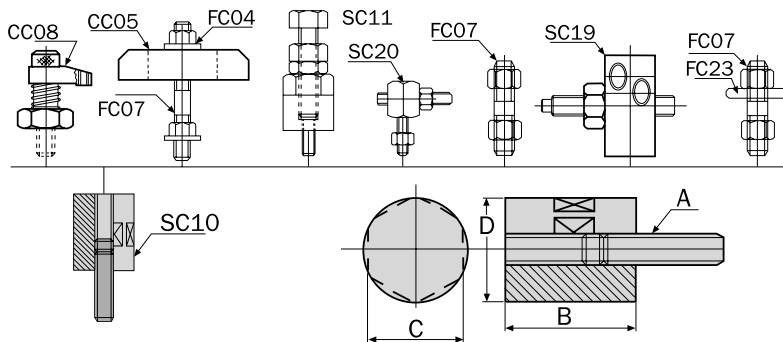

**Material:** Medium Carbon Steel.  
**Hardness:** HRC 40.  
**Surface Finish:** Black Oxide.



| Product Number | Height x Diameter A x B | Dimensions (mm) |    | Weight each | Order Code                      | List Price/1 | Offer Price/1 |
|----------------|-------------------------|-----------------|----|-------------|---------------------------------|--------------|---------------|
|                |                         | C               | D  |             |                                 |              |               |
| SC100265       | M12 x 65                | 36              | 40 | 540g        | <b>IND-425</b><br><b>-3050F</b> | £25.30       | <b>£23.28</b> |
| SC100450       | M16 x 50                | 46              | 50 | 820g        | <b>-3050J</b>                   | £26.98       | <b>£24.82</b> |

**SC11A - Screw Jack**

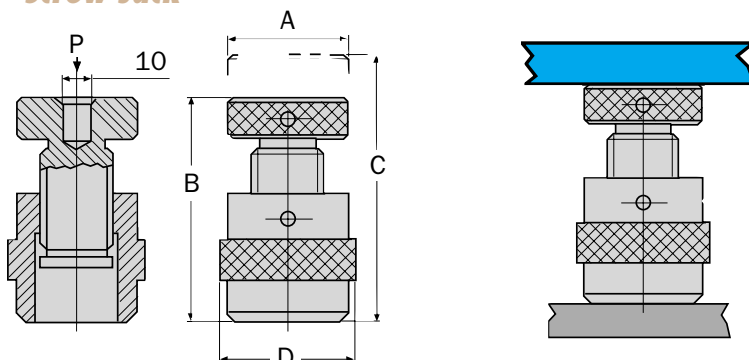

**Material:** Medium Carbon Steel.  
**Hardness:** HRC 40.  
**Surface Finish:** Black Oxide.



| Product Number | Diameter x Height A x B (Min) | Dimensions (mm) |    | Holding Load (kN) | Weight each | Order Code                      | List Price/1 | Offer Price/1 |
|----------------|-------------------------------|-----------------|----|-------------------|-------------|---------------------------------|--------------|---------------|
|                |                               | C               | D  |                   |             |                                 |              |               |
| SC20032050     | 32 x 40mm                     | 60              | 32 | 72                | 230g        | <b>IND-425</b><br><b>-3057D</b> | £21.77       | <b>£20.03</b> |
| SC20070140     | 65 x 100mm                    | 165             | 70 | 135               | 274g        | <b>-3057P</b>                   | £86.50       | <b>£79.58</b> |

Workshop Equipment

**INDEXA** SC17 - Vee Block



**Material:**  
Medium Carbon Steel **EN9**.  
Induction Hardened.

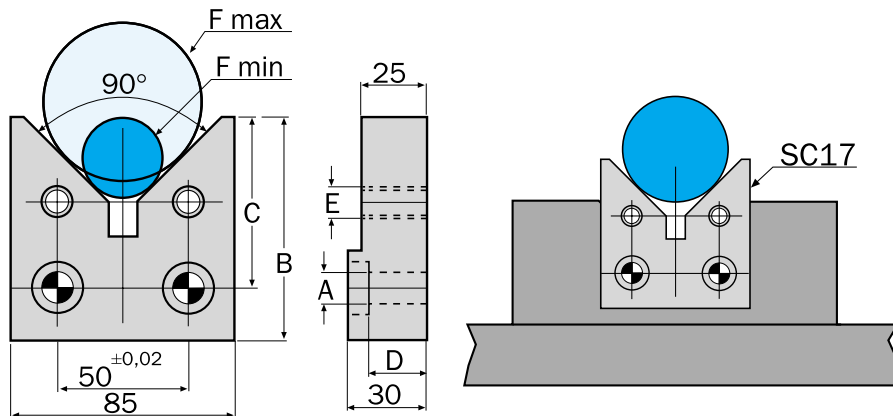

| Product Number | Size<br>A (F7) x B x C | Dimensions (mm) |    |         |         | Weight each | Order Code                      | List Price/1 | Offer Price/1 |
|----------------|------------------------|-----------------|----|---------|---------|-------------|---------------------------------|--------------|---------------|
|                |                        | E               | D  | F (max) | F (min) |             |                                 |              |               |
| SC170112       | ∅ 12 x 85 x 65mm       | M12             | 22 | 80      | 15      | 1.25kg      | <b>IND-425</b><br><b>-3085E</b> | £89.03       | <b>£81.91</b> |

**SU25 - Step Block**

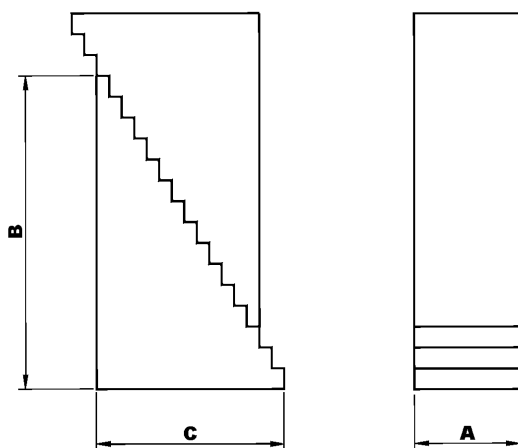

**Material:** Medium Carbon Steel.  
**Hardness:** HRC 32 - 36.  
**Surface Finish:**  
Black Oxide.



| Product Number | Supporting Height | Dimensions (mm) |      |    | Weight each | Order Code    | List Price/1 | Offer Price/1 |
|----------------|-------------------|-----------------|------|----|-------------|---------------|--------------|---------------|
|                |                   | A               | B    | C  |             |               |              |               |
| SU252530       | 19 - 49           |                 | 29   | 17 | 0.05kg      | <b>-3125E</b> | £3.35        | <b>£3.08</b>  |
| SU252545       | 28 - 68           | 25              | 45   | 27 | 0.12kg      | <b>-3125H</b> | £4.32        | <b>£3.97</b>  |
| SU252597       | 58 - 150          |                 | 97.5 | 57 | 0.50kg      | <b>-3125L</b> | £9.50        | <b>£8.74</b>  |
| SU253259       | 38 - 90           |                 | 59   | 35 | 0.24kg      | <b>-3132J</b> | £5.73        | <b>£5.27</b>  |
| SU253297       | 58 - 150          | 32              | 97.5 | 57 | 0.62kg      | <b>-3132L</b> | £11.45       | <b>£10.53</b> |
| SU2532139      | 82 - 210          |                 | 139  | 81 | 1.32kg      | <b>-3132P</b> | £17.17       | <b>£15.80</b> |

**SEB - Shoulder Bolt**

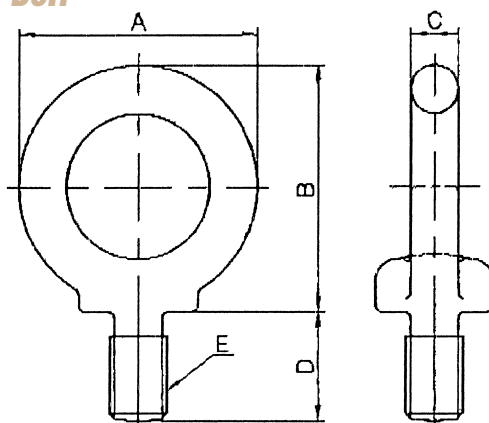

| Product Number | Thread (E) | Dimensions (mm) |      |      |    | Load  | Weight each | Order Code                      | List Price/1 | Offer Price/1 |
|----------------|------------|-----------------|------|------|----|-------|-------------|---------------------------------|--------------|---------------|
|                |            | A               | B    | C    | D  |       |             |                                 |              |               |
| SEB1017        | M10        | 41              | 41.5 | 8    | 18 | 150kg | 0.063kg     | <b>IND-425</b><br><b>-3210S</b> | £1.47        | <b>£1.35</b>  |
| SEB1220        | M12        | 50              | 51   | 10   | 22 | 220kg | 0.125kg     | <b>-3212S</b>                   | £2.38        | <b>£2.19</b>  |
| SEB1525        | M16        | 60              | 60   | 12.5 | 27 | 450kg | 0.216kg     | <b>-3216S</b>                   | £3.55        | <b>£3.27</b>  |
| SEB2030        | M20        | 72              | 71   | 16   | 30 | 630kg | 0.4kg       | <b>-3220S</b>                   | £6.54        | <b>£6.02</b>  |

**CONTRACT PRICES AVAILABLE FOR VOLUME PURCHASES**

All Prices Exclude V.A.T. © 2013

Workshop Equipment

**Silver Steel**

For tool room and general engineering. Applications include screwdrivers, punches, shafts, axles, pinions, pins, die posts, instrument parts, model parts, taps and drills for mild steel, engraver tools.

High carbon content means that it can be hardened to give high wear resistance and chromium content adds strength and hardness.

Manufactured from **BS1407:1970 grade steel.**

**Typical hardness:** 207-237HB with 285HB maximum.

**Tensile strength:** 45/55 T.P.S.I. (700/850 N/mm<sup>2</sup>).

**Surface finish:** Better than 0.6 microns (25 micro inch) CLA (Centre Line Average).

**Chemical analysis:**

|             | Range        | Typical |
|-------------|--------------|---------|
| Carbon      | 0.95 - 1.25% | 1.13%   |
| Silicon     | 0.40% max    | 0.22%   |
| Manganese   | 0.25 - 0.45% | 0.37%   |
| Phosphorous | 0.045% max   | 0.014%  |
| Sulphur     | 0.045% max   | 0.018%  |
| Chromium    | 0.35 - 0.45% | 0.43%   |

**Metric Round Sizes**

**Tolerances:**  
Up to 25mm +0 - 0.012mm.  
Over 25mm up to and including 50mm +0 - 0.0250mm.

| Diameter (mm) | Length (mm) | Weight per metre | Order Code CTL-432 | List Price/1 | Offer Price/1 |
|---------------|-------------|------------------|--------------------|--------------|---------------|
| 1.0           | 333         |                  | -5294J             | £3.14        | <b>£1.85</b>  |
| 1.5           | 333         |                  | -5297M             | £3.65        | <b>£2.15</b>  |
| 2.0           | 333         | 0.02kg           | -5300A             | £0.42        | <b>£0.25</b>  |
|               | 1000        |                  | -5301B             | £1.26        | <b>£0.74</b>  |
|               | 333         |                  | -5303D             | £0.58        | <b>£0.34</b>  |
| 2.5           | 1000        | 0.04kg           | -5304E             | £1.74        | <b>£1.03</b>  |
|               | 2000        |                  | -5305F             | £3.48        | <b>£2.05</b>  |
|               | 333         |                  | -5306G             | £0.70        | <b>£0.41</b>  |
| 3.0           | 1000        | 0.05kg           | -5307H             | £2.10        | <b>£1.24</b>  |
|               | 2000        |                  | -5308J             | £4.20        | <b>£2.48</b>  |
|               | 333         |                  | -5309K             | £0.88        | <b>£0.52</b>  |
| 3.5           | 1000        | 0.07kg           | -5310L             | £2.64        | <b>£1.56</b>  |
|               | 2000        |                  | -5311M             | £5.28        | <b>£3.12</b>  |
|               | 333         |                  | -5312N             | £0.93        | <b>£0.55</b>  |
| 4.0           | 1000        | 0.10kg           | -5313P             | £2.79        | <b>£1.65</b>  |
|               | 2000        |                  | -5314Q             | £5.58        | <b>£3.29</b>  |
|               | 333         |                  | -5315R             | £1.35        | <b>£0.80</b>  |
| 4.5           | 1000        | 0.12kg           | -5316S             | £4.05        | <b>£2.39</b>  |
|               | 333         |                  | -5318V             | £1.26        | <b>£0.74</b>  |
| 5.0           | 1000        | 0.15kg           | -5319W             | £3.78        | <b>£2.23</b>  |
|               | 2000        |                  | -5320X             | £7.56        | <b>£4.46</b>  |
|               | 333         |                  | -5321Y             | £1.72        | <b>£1.01</b>  |
| 5.5           | 1000        | 0.18kg           | -5322Z             | £5.16        | <b>£3.04</b>  |
|               | 333         |                  | -5325B             | £1.77        | <b>£1.04</b>  |
| 6.0           | 1000        | 0.22kg           | -5326C             | £5.31        | <b>£3.13</b>  |
|               | 2000        |                  | -5327D             | £10.62       | <b>£6.27</b>  |
|               | 333         |                  | -5328E             | £1.92        | <b>£1.13</b>  |
| 6.5           | 1000        | 0.26kg           | -5329F             | £5.76        | <b>£3.40</b>  |
|               | 333         |                  | -5331H             | £2.09        | <b>£1.23</b>  |
| 7.0           | 1000        | 0.30kg           | -5332J             | £6.27        | <b>£3.70</b>  |
|               | 2000        |                  | -5333K             | £12.54       | <b>£7.40</b>  |
|               | 333         |                  | -5334L             | £2.56        | <b>£1.51</b>  |
| 7.5           | 1000        | 0.35kg           | -5335M             | £7.68        | <b>£4.53</b>  |
|               | 333         |                  | -5337P             | £2.38        | <b>£1.40</b>  |
| 8.0           | 1000        | 0.39kg           | -5338Q             | £7.14        | <b>£4.21</b>  |
|               | 2000        |                  | -5339R             | £14.28       | <b>£8.43</b>  |
|               | 333         |                  | -5340S             | £3.16        | <b>£1.86</b>  |
| 8.5           | 333         | 0.44kg           | -5343W             | £3.10        | <b>£1.83</b>  |
|               | 333         |                  | -5344X             | £9.30        | <b>£5.49</b>  |
| 9.0           | 1000        | 0.50kg           | -5345Y             | £18.60       | <b>£10.97</b> |
|               | 333         |                  | -5346Z             | £3.92        | <b>£2.31</b>  |
|               | 333         |                  | -5350C             | £3.69        | <b>£2.18</b>  |
| 10.0          | 1000        | 0.61kg           | -5351D             | £11.07       | <b>£6.53</b>  |
|               | 2000        |                  | -5352E             | £22.14       | <b>£13.06</b> |
|               | 333         |                  | -5353F             | £4.85        | <b>£2.86</b>  |
|               | 333         |                  | -5356J             | £4.53        | <b>£2.67</b>  |
| 11.0          | 1000        | 0.74kg           | -5357K             | £13.59       | <b>£8.02</b>  |
|               | 2000        |                  | -5358L             | £27.18       | <b>£16.04</b> |
|               | 333         |                  | -5359M             | £6.04        | <b>£3.56</b>  |



**Silver Steel - Metric**

**Continued**

| Diameter (mm) | Length (mm) | Weight per metre | Order Code CTL-432 | List Price/1 | Offer Price/1 |
|---------------|-------------|------------------|--------------------|--------------|---------------|
| 38.0          | 333         | 8.90kg           | -5469B             | £47.93       | <b>£28.28</b> |
| 40.0          | 333         | 9.80kg           | -5475H             | £51.22       | <b>£30.22</b> |
|               | 1000        |                  | -5476J             | £153.66      | <b>£90.66</b> |
| 45.0          | 333         |                  | -5478L             | £65.71       | <b>£38.77</b> |
| 50.0          | 333         | 15.40kg          | -5481P             | £79.83       | <b>£47.10</b> |

**Silver Steel - Inch Round Sizes**

**Tolerances:**  
Below 1" +/- 0.00025".  
1" up to and including 2" +/- 0.00050".

| Diameter | Length | Weight per 39" | Order Code CTL-432 | List Price/1 | Offer Price/1 |
|----------|--------|----------------|--------------------|--------------|---------------|
| 1/32"    | 13"    |                | -5006V             | £1.11        | <b>£0.65</b>  |
| 3/64"    | 13"    |                | -5008X             | £1.68        | <b>£0.99</b>  |
| 1/16"    | 13"    | 0.01kg         | -5010A             | £0.53        | <b>£0.31</b>  |
|          | 13"    |                | -5013D             | £0.55        | <b>£0.32</b>  |
|          | 78"    | 0.03kg         | -5015F             | £3.30        | <b>£1.95</b>  |
|          | 13"    |                | -5016G             | £0.69        | <b>£0.41</b>  |
| 1/8"     | 39"    | 0.06kg         | -5017H             | £2.07        | <b>£1.22</b>  |
|          | 78"    |                | -5018J             | £4.14        | <b>£2.44</b>  |
|          | 13"    |                | -5019K             | £1.06        | <b>£0.63</b>  |
| 5/32"    | 39"    | 0.10kg         | -5020L             | £3.18        | <b>£1.88</b>  |
|          | 78"    |                | -5021M             | £6.36        | <b>£3.75</b>  |
|          | 13"    |                | -5022N             | £1.10        | <b>£0.65</b>  |
| 3/16"    | 39"    | 0.14kg         | -5023P             | £3.30        | <b>£1.95</b>  |
|          | 78"    |                | -5024Q             | £6.60        | <b>£3.89</b>  |
|          | 13"    |                | -5025R             | £1.76        | <b>£1.04</b>  |
| 7/32"    | 39"    | 0.19kg         | -5026S             | £5.28        | <b>£3.12</b>  |
|          | 78"    |                | -5027T             | £10.56       | <b>£6.23</b>  |
| 15/64"   | 13"    |                | -5028H             | £3.00        | <b>£1.77</b>  |
|          | 13"    |                | -5028V             | £1.66        | <b>£0.98</b>  |
| 1/4"     | 39"    | 0.25kg         | -5029W             | £4.98        | <b>£2.94</b>  |
|          | 78"    |                | -5030X             | £9.96        | <b>£5.88</b>  |
|          | 13"    |                | -5031Y             | £2.53        | <b>£1.49</b>  |
| 9/32"    | 13"    | 0.31kg         | -5035B             | £2.53        | <b>£1.49</b>  |
|          | 39"    | 0.39kg         | -5036C             | £7.59        | <b>£4.48</b>  |
|          | 78"    |                | -5037D             | £15.18       | <b>£8.96</b>  |
| 11/32"   | 13"    | 0.47kg         | -5038E             | £3.69        | <b>£2.18</b>  |
|          | 13"    |                | -5041H             | £3.36        | <b>£1.98</b>  |
| 3/8"     | 39"    | 0.56kg         | -5042J             | £10.08       | <b>£5.95</b>  |
|          | 78"    |                | -5043K             | £20.16       | <b>£11.89</b> |
| 25/64"   | 13"    |                | -5043Y             | £9.28        | <b>£5.48</b>  |
| 13/32"   | 13"    |                | -5044L             | £4.73        | <b>£2.79</b>  |
|          | 13"    |                | -5047P             | £4.64        | <b>£2.74</b>  |
| 7/16"    | 39"    | 0.76kg         | -5048Q             | £13.92       | <b>£8.21</b>  |
|          | 78"    |                | -5049R             | £27.84       | <b>£16.43</b> |
| 15/32"   | 13"    | 0.87kg         | -5050S             | £6.89        | <b>£4.07</b>  |
|          | 13"    |                | -5053W             | £5.30        | <b>£3.13</b>  |
| 1/2"     | 39"    | 0.99kg         | -5054X             | £15.90       | <b>£9.38</b>  |
|          | 78"    |                | -5055Y             | £31.80       | <b>£18.76</b> |
| 33/64"   | 13"    |                | -5056M             | £10.50       | <b>£6.20</b>  |
| 17/32"   | 13"    | 1.12kg         | -5056Z             | £7.38        | <b>£4.35</b>  |
| 35/64"   | 13"    |                | -5059B             | £10.91       | <b>£6.44</b>  |
|          | 13"    |                | -5060C             | £6.71        | <b>£3.96</b>  |
| 9/16"    | 39"    | 1.25kg         | -5061D             | £20.13       | <b>£11.88</b> |
| 19/32"   | 13"    | 1.40kg         | -5063F             | £9.11        | <b>£5.37</b>  |
|          | 13"    |                | -5066J             | £7.52        | <b>£4.44</b>  |
| 5/8"     | 39"    | 1.55kg         | -5067K             | £22.56       | <b>£13.31</b> |
|          | 78"    |                | -5068L             | £45.12       | <b>£26.62</b> |
| 21/32"   | 13"    |                | -5069M             | £10.29       | <b>£6.07</b>  |
|          | 13"    |                | -5072Q             | £9.36        | <b>£5.52</b>  |
| 11/16"   | 39"    | 1.88kg         | -5073R             | £28.08       | <b>£16.57</b> |
| 23/32"   | 13"    |                | -5075T             | £12.37       | <b>£7.30</b>  |
|          | 13"    |                | -5078X             | £10.76       | <b>£6.35</b>  |
| 3/4"     | 39"    | 2.23kg         | -5079Y             | £32.28       | <b>£19.05</b> |
|          | 78"    |                | -5080Z             | £64.56       | <b>£38.09</b> |
| 25/32"   | 13"    |                | -5081M             | £15.00       | <b>£8.85</b>  |
| 13/16"   | 13"    | 2.62kg         | -5082A             | £13.55       | <b>£7.99</b>  |
|          | 13"    |                | -5085D             | £14.06       | <b>£8.30</b>  |
| 7/8"     | 39"    | 3.00kg         | -5086E             | £42.18       | <b>£24.89</b> |
|          | 39"    |                | -5086V             | £42.18       | <b>£24.89</b> |
| 29/32"   | 13"    |                | -5087V             | £21.19       | <b>£12.50</b> |
| 59/64"   | 13"    |                | -5088A             | £21.56       | <b>£12.72</b> |
| 15/16"   | 13"    | 3.50kg         | -5088G             | £17.39       | <b>£10.26</b> |
|          | 13"    |                | -5091K             | £17.12       | <b>£10.10</b> |
| 1"       | 39"    | 3.90kg         | -5092L             | £51.36       | <b>£30.30</b> |
|          | 78"    |                | -5093M             | £102.72      | <b>£60.60</b> |
|          | 13"    |                | -5094N             | £21.47       | <b>£12.67</b> |
| 1 1/8"   | 39"    | 5.00kg         | -5095P             | £64.42       | <b>£38.01</b> |
|          | 39"    |                | -5097R             | £26.65       | <b>£15.72</b> |
| 1 1/4"   | 39"    | 6.20kg         | -5098S             | £79.95       | <b>£47.17</b> |
| 1 3/8"   | 13"    | 7.50kg         | -5100V             | £31.70       | <b>£18.70</b> |
|          | 13"    |                | -5103Y             | £38.61       | <b>£22.78</b> |
| 1 1/2"   | 39"    | 8.50kg         | -5104Z             | £115.83      | <b>£68.34</b> |
| 1 3/4"   | 13"    | 12.20kg        | -5107B             | £52.13       | <b>£30.76</b> |
| 2"       | 13"    |                | -5110E             | £72.80       | <b>£42.95</b> |

**INDEXA** Type 5821 Horizontal & Vertical Indexing Units

Ideal for milling, drilling, jig boring and related tool room machining operations. Indexing accuracy  $\pm 120$  sec.

Simple and compact construction allows two types of dividing:

**Angular Indexing**

Through the graduation ring from 0° to 360° in increments of 1°.

**Basic Indexing**

By means of catch device. This permits divisions of

2, 3, 4, 6, 8, 12 and 24 without disassembly.

Fitted with standard 3-jaw self-centring scroll chuck with 2-piece reversible jaws, model -0400K has a special design allowing the use of 5C collets.

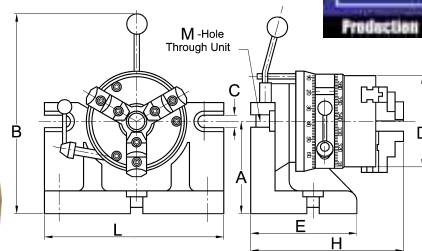
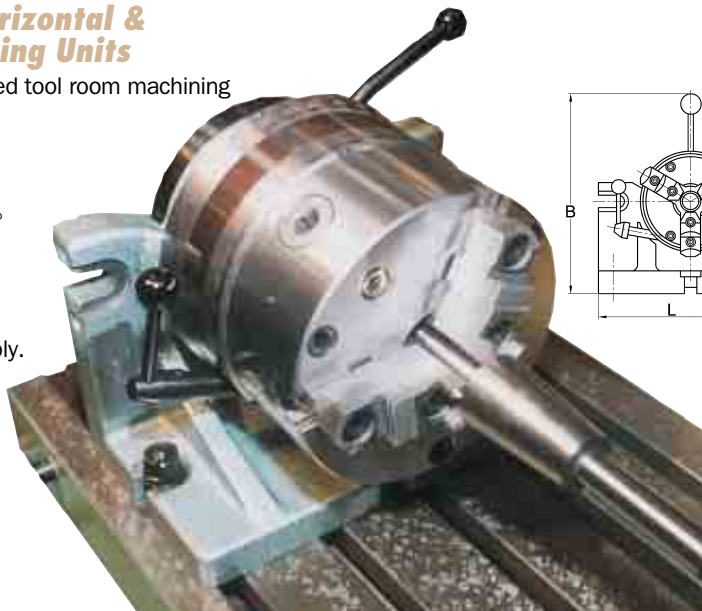

**For Indexable Tooling**

**See Group 106**

| Chuck Diameter | Dimensions (mm) |     |     |    |    |     |     |     |      |        | Weight each   | Order Code <b>IND-437</b> | List Price/1    | Offer Price/1 |
|----------------|-----------------|-----|-----|----|----|-----|-----|-----|------|--------|---------------|---------------------------|-----------------|---------------|
|                | A               | G   | B   | C  | E  | F   | H   | L   | M    |        |               |                           |                 |               |
| 125mm          | 100             | 167 | 254 | 14 | 14 | 130 | 215 | 206 | 25.0 | 17.8kg | <b>-0400K</b> | £796.91                   | <b>£573.78</b>  |               |
| 160mm          | 125             | 210 | 303 | 14 | 14 | 145 | 245 | 214 | 20.2 | 34.0kg | <b>-0410K</b> | £911.10                   | <b>£655.99</b>  |               |
| 200mm          | 160             | 265 | 384 | 18 | 18 | 160 | 300 | 244 | 26.5 | 58.0kg | <b>-0420K</b> | £1234.76                  | <b>£889.03</b>  |               |
| 250mm          | 200             | 330 | 473 | 18 | 18 | 185 | 340 | 277 | 38.2 | 94.0kg | <b>-0430K</b> | £1605.38                  | <b>£1155.87</b> |               |

**Type SOPP Horizontal & Vertical Rotary Tables**

With a disengageable worm gear which allows rapid indexing. One rotation of handle equals four degrees on collar. The table is made of high grade cast iron. Works as an indexing unit in the vertical position as well as a conventional rotary table for circular cutting, boring or angle setting, etc. Optional dividing plates are available separately.

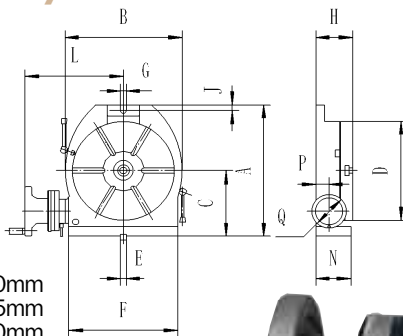

**Accuracy:**  
 Parallelism of clamping surface to base: 0.020mm  
 Flatness of clamping surface: 0.015mm  
 True running cylindrical centre bore: 0.020mm  
 True running of tapered centre bore: 0.020mm  
 Squareness of clamping surface to centre slot: 0.010mm

**Optional Extras**

| Description                             | Order Code <b>IND-437</b> | List Price/1 | Offer Price/1  |
|---|---------------------------|--------------|----------------|
| Dividing Plate for INDEXA Rotary Tables | <b>-1000K</b>             | £164.00      | <b>£118.08</b> |

**Rotary Tables**

| Diameter D | Max. Capacity C | Centre Hole M | Dimensions (mm) |     |    |     |    |     |    |     |     |    |     | No. of T-slots | Weight each | Order Code <b>IND-437</b> | List Price/1 | Offer Price/1  |
|------------|-----------------|---------------|-----------------|-----|----|-----|----|-----|----|-----|-----|----|-----|----------------|-------------|---------------------------|--------------|----------------|
|            |                 |               | A               | B   | E  | F   | G  | H   | J  | L   | N   | P  | Q   |                |             |                           |              |                |
| 200mm      | 150             | 3 MT          | 285             | 236 | 14 | 208 | 14 | 100 | 15 | 211 | 99  | 48 | 125 | 4              | 42kg        | <b>-0500K</b>             | £472.00      | <b>£339.84</b> |
| 250mm      | 170             | 3 MT          | 328             | 286 | 14 | 253 | 14 | 110 | 16 | 241 | 106 | 48 | 125 | 6              | 57kg        | <b>-0510K</b>             | £570.00      | <b>£410.40</b> |
| 320mm      | 210             | 4 MT          | 410             | 360 | 18 | 320 | 18 | 120 | 16 | 273 | 118 | 48 | 140 | 6              | 92kg        | <b>-0520K</b>             | £653.00      | <b>£470.16</b> |

**Horizontal & Vertical Index Unit Chucks**

Ideal for indexing items to be machined in pre-set or manually set incremental angles. Indexing accuracy 25 seconds. Angular indexing through the graduation ring from 0 to 360 degrees in 1 degree increments. Basic indexing by means of a catch device permitting divisions of 2, 3, 4, 6, 8, 12 and 24 without disassembly.

Fitted with standard three jaw self-centring scroll chuck with two sets of jaws, for inside and outside gripping.

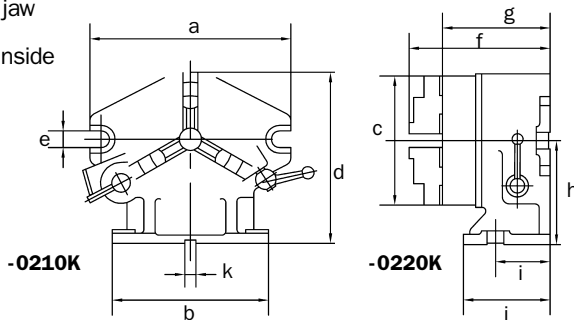

**NEW**

| Chuck Diameter | Dimensions (mm) |     |     |        |    |       |       |        |    |     |    | Weight each | Order Code <b>IND-437</b> | List Price/1 | Offer Price/1  |
|----------------|-----------------|-----|-----|--------|----|-------|-------|--------|----|-----|----|-------------|---------------------------|--------------|----------------|
|                | A               | B   | C   | D      | E  | F     | G     | H      | I  | J   | K  |             |                           |              |                |
| 167mm          | 260             | 220 | 167 | 220.00 | 18 | 197.5 | 155.5 | 130.00 | 70 | 130 | 16 | 17.8kg      | <b>-0210K</b>             | £488.80      | <b>£351.94</b> |
| 220mm          | 310             | 255 | 210 | 255.25 | 18 | 214.0 | 171.5 | 149.25 | 80 | 150 | 16 | 94.0kg      | <b>-0220K</b>             | £580.40      | <b>£417.89</b> |

**CONTRACT PRICES AVAILABLE FOR VOLUME PURCHASES**

**GROUP 440 CHUCKS**

**KENNEDY** *Extra Keyless Drill Chuck*

Designed for use on cordless screwdrivers, cordless and cored drills. Unique gripping mechanism engages automatically when tightened. Fully hardened and ground jaws protect against work surface abrasion. Through drilled for use on reversible drills.



| Capacity (mm) | Mount      | Weight each | Order Code <b>KEN-440</b> | List Price/1 | Offer Price/1 |
|---------------|------------|-------------|---------------------------|--------------|---------------|
| 1 - 10        | 3/8" - 24F |             | <b>-4720K</b>             | £22.45       | <b>£16.39</b> |
| 1.5 - 13      | 3/8" - 24F |             | <b>-4760K</b>             | £30.11       | <b>£21.98</b> |
| 1 - 10        | 1/2" - 20F |             | <b>-4700K</b>             | £22.45       | <b>£16.39</b> |
| 1.5 - 13      | 1/2" - 20F |             | <b>-4740K</b>             | £30.11       | <b>£21.98</b> |

**Extra-RV Drill Chuck**

Radial locking. Suitable for use on impact drills. Maintains full gripping pressure on the drill bit during hammer drilling. Compensates and absorbs the vibration and forces produced when hammer drilling, unlike rigid gripping chucks, preventing drill slippage and providing consistent performance under severe conditions. Fully hardened and ground jaws protect against work surface abrasion. Through drilled for use on reversible drills.



| Capacity (mm) | Mount      | Maximum Diameter | Weight each | Order Code <b>KEN-440</b> | List Price/1 | Offer Price/1 |
|---------------|------------|------------------|-------------|---------------------------|--------------|---------------|
| 13.0          | 3/8" - 24F | 42.8             | 310g        | <b>-3860K</b>             | £37.30       | <b>£27.23</b> |
| 13.0          | 1/2" - 20F | 42.8             | 310g        | <b>-3880K</b>             | £37.30       | <b>£27.23</b> |

**KOBE** *Drill Chuck*

Fully hardened and ground for durability and wear resistance. Suitable for use with portable power tools.



| Capacity (mm) | Mount      | Weight each | Order Code <b>KBE-440</b> | List Price/1 | Offer Price/1 |
|---------------|------------|-------------|---------------------------|--------------|---------------|
| 1.0 - 10.0    | 3/8" - 24F |             | <b>-2010A</b>             | £18.03       | <b>£13.16</b> |
| 1.5 - 13.0    | 3/8" - 24F |             | <b>-2020B</b>             | £21.31       | <b>£15.56</b> |
| 1.5 - 13.0    | 1/2" - 20F |             | <b>-2030C</b>             | £21.31       | <b>£15.56</b> |

**Jacobs** *Hand-Tite® Keyless Chuck*

Hammer-capable Hand-Tite® chucks are designed specifically for use on professional hammer drills. Will fit reversing as well as non-reversible drills



| Model Number | Mount      | Capacity (mm) | Weight each | Order Code <b>JAC-440</b> | List Price/1 | Offer Price/1 |
|--------------|------------|---------------|-------------|---------------------------|--------------|---------------|
| 31213        | 3/8" - 24F | 1.5 - 10      | 150g        | <b>-4781B</b>             | £22.56       | <b>£18.50</b> |
| 30758        | 1/2" - 20F | 1.5 - 10      | 150g        | <b>-4780A</b>             | £22.56       | <b>£18.50</b> |
| 30818        | 3/8" - 24F | 2 - 13        | 300g        | <b>-4803C</b>             | £30.25       | <b>£24.80</b> |
| 30777        | 1/2" - 20F | 2 - 13        | 300g        | <b>-4801A</b>             | £30.25       | <b>£24.80</b> |

**KENNEDY** *Spiro-Rapid Clamping Keyless Drill Chuck*

Allows quick tool change, while maintaining high precision and high concentricity. Fully hardened jaws, sleeve and retaining ring for durability and wear resistance. Self-tightening.



| Capacity (mm) | Mount | Maximum Diameter | Weight each | Order Code <b>KEN-440</b> | List Price/1 | Offer Price/1 |
|---------------|-------|------------------|-------------|---------------------------|--------------|---------------|
| 4.0           | 1JT   | 28.0             | 150g        | <b>-3010K</b>             | £104.41      | <b>£76.22</b> |
| 8.0           | B12   | 38.0             | 420g        | <b>-3100K</b>             | £90.53       | <b>£66.09</b> |
| 8.0           | 1JT   | 38.0             | 440g        | <b>-3110K</b>             | £90.53       | <b>£66.09</b> |
| 10.0          | 2JT   | 43.0             | 720g        | <b>-3220K</b>             | £95.24       | <b>£69.53</b> |
| 10.0          | 33JT  | 43.0             | 740g        | <b>-3250K</b>             | £95.20       | <b>£69.50</b> |
| 13.0          | 2JT   | 50.0             | 1000g       | <b>-3320K</b>             | £102.75      | <b>£75.01</b> |
| 13.0          | 6JT   | 50.0             | 1000g       | <b>-3340K</b>             | £102.75      | <b>£75.01</b> |
| 16.0          | 6JT   | 55.0             | 1200g       | <b>-3440K</b>             | £119.57      | <b>£87.29</b> |

**Supra-Rapid Clamping Industrial Keyless Drill Chuck**

Fully hardened and ground working parts. The jaws are centre ground for alignment concentricity. Robustly designed for durability and wear resistance in the most arduous of industrial applications on stationary drilling machines. Unsuitable for reversing drills.



| Capacity (mm) | Mount      | Maximum Diameter | Weight each | Order Code <b>KEN-440</b> | List Price/1 | Offer Price/1 |
|---------------|------------|------------------|-------------|---------------------------|--------------|---------------|
| 10.0          | 2JT        | 42.5             | 670g        | <b>-4120K</b>             | £57.24       | <b>£41.79</b> |
| 10.0          | DIN-B12    | 42.5             | 670g        | <b>-5220K</b>             | £59.09       | <b>£43.14</b> |
| 10.0          | DIN-B16    | 42.5             | 690g        | <b>-5240K</b>             | £59.09       | <b>£43.14</b> |
| 13.0          | 6JT        | 46.0             | 920g        | <b>-4240K</b>             | £68.82       | <b>£50.24</b> |
| 13.0          | 1/2" - 20F | 46.0             | 660g        | <b>-4280K</b>             | £46.88       | <b>£34.22</b> |
| 13.0          | DIN-B12    | 46.0             | 900g        | <b>-5260K</b>             | £59.84       | <b>£43.68</b> |
| 13.0          | DIN-B16    | 46.0             | 940g        | <b>-5280K</b>             | £71.07       | <b>£51.88</b> |
| 16.0          | 6JT        | 51.0             | 1100g       | <b>-4340K</b>             | £80.39       | <b>£58.68</b> |
| 16.0          | DIN-B16    | 51.0             | 1090g       | <b>-5300K</b>             | £82.99       | <b>£60.58</b> |

**Jacobs** *Industrial Keyless Chuck*

Keyless operation for efficiency and speedy bit changes, available with threaded mounts for power tools or taper mounts for use on machine tools.



| Model Number | Mount      | Capacity (mm) | Weight each | Order Code <b>JAC-440</b> | List Price/1 | Offer Price/1 |
|--------------|------------|---------------|-------------|---------------------------|--------------|---------------|
| J6.5         | JT1        | 0 - 8         | 300g        | <b>-2550A</b>             | £36.93       | <b>£30.28</b> |
| J6.5         | 3/8" x 24F | 0 - 6.5       | 300g        | <b>-2553D</b>             | £36.93       | <b>£30.28</b> |
| J10          | 3/8" x 24F | 1 - 10        | 350g        | <b>-2560L</b>             | £45.26       | <b>£37.11</b> |
| J13          | JT6        | 1 - 13        | 650g        | <b>-2562N</b>             | £55.51       | <b>£45.52</b> |
| J13          | JT33       | 1 - 13        | 650g        | <b>-2563L</b>             | £55.51       | <b>£45.52</b> |
| J13          | 1/2" x 20F | 1 - 13        | 650g        | <b>-2565R</b>             | £55.51       | <b>£45.52</b> |
| J16          | JT3        | 3 - 16        | 1050g       | <b>-2566P</b>             | £68.47       | <b>£56.15</b> |
| J16          | JT6        | 3 - 16        | 1050g       | <b>-2566S</b>             | £68.47       | <b>£56.15</b> |
| J16          | 1/2" x 20F | 3 - 16        | 1100g       | <b>-2569W</b>             | £68.47       | <b>£56.15</b> |
| J16          | 5/8" x 16F | 3 - 16        | 1100g       | <b>-2570X</b>             | £68.47       | <b>£56.15</b> |

Workshop Equipment

## JACOBS Plain Bearing Chuck



Designed for medium or heavy duty portable, bench or floor mounted power tools. Industrial quality with fully hardened and ground working components which offers high accuracy, gripping power and durability. Each chuck has centre ground jaws for absolute straightness and alignment, through hardened sleeve teeth plus hardened nose and keyholes to provide wear resistance. The one piece sleeve eliminates crack between the driving teeth.



| Model Number | Mount    | Capacity (mm) | Key | Weight each | Order Code JAC-440 | List Price/1 | Offer Price/1 |
|--------------|----------|---------------|-----|-------------|--------------------|--------------|---------------|
| 0            | 0JT      | 0.711-4       | K0  | 60g         | -2500A             | £48.87       | £40.07        |
| 0B           | 5/16"-24 | 0.711-4       | K0  | 60g         | -2501B             | £48.87       | £40.07        |
| 1A           | 1JT      | 0.711-6.5     | K1  | 140g        | -2502C             | £28.95       | £23.74        |
| 1B           | 3/8"-24  | 0.711-6.5     | K1  | 140g        | -2504E             | £28.95       | £23.74        |
| 2A           | 2JT      | 0.711-10      | K2  | 370g        | -2506G             | £36.75       | £30.14        |
| 31-01        | 1JT      | 0.711-10      | K30 | 230g        | -2520D             | £32.71       | £26.82        |
| 31-02        | 2JT      | 0.711-10      | K30 | 230g        | -2520H             | £32.71       | £26.82        |
| 33KD         | 33JT     | 2-13          | K32 | 480g        | -2531H             | £45.64       | £37.42        |
| 34-02        | 2JT      | 0.711-13      | K3  | 650g        | -2531M             | £44.43       | £36.43        |
| 34-06        | 6JT      | 0.711-13      | K3  | 650g        | -2531R             | £44.43       | £36.43        |
| 34-33        | 33JT     | 0.711-13      | K3  | 650g        | -2531W             | £44.43       | £36.43        |
| 33           | 33JT     | 2-13          | K32 | 450g        | -2527D             | £39.71       | £32.56        |
| 3A           | 3JT      | 3-16          | K3  | 900g        | -2508J             | £53.18       | £43.61        |
| 3B           | 5/8"-16  | 3-16          | K3  | 900g        | -2509K             | £53.18       | £43.61        |
| 36           | 3JT      | 5-20.3        | K4  | 1280g       | -2535M             | £73.77       | £60.49        |
| 36B          | 3/4"-16  | 5-20.3        | K4  | 1300g       | -2537P             | £73.77       | £60.49        |

## Reversible Chuck

Drilled and countersunk for retaining screw, suitable for reversible tools.



| Model Number | Mount   | Capacity (mm) | Key | Weight each | Order Code JAC-440 | List Price/1 | Offer Price/1 |
|--------------|---------|---------------|-----|-------------|--------------------|--------------|---------------|
| 7B           | 3/8"-24 | 0.711-6.5     | K7  | 200g        | -2514P             | £30.97       | £25.40        |
| 2BA          | 3/8"-24 | 0.711-10      | K2  | 370g        | -2507H             | £36.75       | £30.14        |
| 41BA         | 1/2"-20 | 0.711-10      | K30 | 230g        | -2522Z             | £32.71       | £26.82        |
| 41BA-S       | 3/8"-24 | 0.711-10      | K30 | 230g        | -2521Y             | £32.71       | £26.82        |
| 41BA-F       | 3/8"-24 | 0.711-10      | K30 | 230g        | -2521D             | £32.71       | £26.82        |
| 32BA         | 1/2"-20 | 0.711-10      | K30 | 400g        | -2526C             | £37.70       | £30.91        |

## Multi-Craft® Chuck

For use on portable power tools for the home/DIY or light duty professional use. Featuring bite hardened jaws. Female mounts have a through-hole to accept a left handed retaining screw on a reversing drill. All manufactured to DIN runout specifications.



| Model Number | Mount      | Capacity (mm) | Key | Weight each | Order Code JAC-440 | List Price/1 | Offer Price/1 |
|--------------|------------|---------------|-----|-------------|--------------------|--------------|---------------|
| K10ACG       | 3/8" x 24F | 1.5-10        | KG  | 135g        | -2602C             | £14.86       | £12.19        |
| K10ACG       | 3/8" x 24M | 1.5-10        | KG  | 135g        | -2603D             | £14.86       | £12.19        |
| K13AC8/10    | 3/8" x 24F | 1.5-13        | S2  | 270g        | -2604E             | £17.69       | £14.51        |
| K13AC8/10    | 1/2" x 20F | 1.5-13        | S2  | 270g        | -2606G             | £17.69       | £14.51        |
| K13AC8/10    | SDS        | 1.5-13        | S2  | 300g        | -2607H             | £25.26       | £20.71        |

## KOBE Drill Chuck

For use with portable power tools. Female mount. Supplied with key. UNF keyed chuck, hardened and ground for durability and wear resistance. For use with reversible drills. Excellent value for money.



| Capacity (mm) | Mount      | Weight each | Order Code KBE-440 | List Price/1 | Offer Price/1 |
|---------------|------------|-------------|--------------------|--------------|---------------|
| 1.0 - 10.0    | 3/8" - 24F | 135g        | -1010A             | £13.11       | £9.57         |
| 1.5 - 13.0    | 3/8" - 24F | 270g        | -1020B             | £16.39       | £11.96        |
| 1.5 - 13.0    | 1/2" - 20F | 270g        | -1030C             | £16.39       | £11.96        |

## KENNEDY Standard Duty Industrial Keyed Drill Chuck

Fully hardened and ground for durability and wear resistance. Suitable for use with portable power tools. Supplied with key.



Manufactured to DIN 6349.

\*Primarily for use with hand operated machines

| Capacity (mm) | Mounting   | Maximum Diameter | Weight each | Order Code KEN-440 | List Price/1 | Offer Price/1 |
|---------------|------------|------------------|-------------|--------------------|--------------|---------------|
| 0.5 - 8       | 3/8" x 24F | 30.0             | 140g        | -2260K             | £14.79       | £10.80        |
| 0.8 - 10.0    | 3/8" x 24F | 34.0             | 240g        | -2360K             | £14.80       | £10.80        |
| 0.8 - 10.0*   | 3/8" x 24M | 34.0             | 250g        | -2370K             | £14.80       | £10.80        |
| 0.8 - 10.0*   | 1/2" x 20F | 34.0             | 220g        | -2380K             | £14.80       | £10.80        |
| 1.5 - 13.0    | 3/8" x 24F | 42.7             | 390g        | -2460K             | £17.61       | £12.86        |
| 1.5 - 13.0    | 3/8" x 24M | 42.7             | 430g        | -2470K             | £17.61       | £12.86        |
| 1.5 - 13.0    | 1/2" x 20F | 42.7             | 390g        | -2480K             | £17.61       | £12.86        |

## Heavy Duty Industrial Keyed Drill Chuck

Fully hardened and ground working parts. The jaws are centre ground for alignment and concentricity. Key holes and teeth are fully hardened for durability and wear resistance. To correctly tighten your keyed drill chuck use all key holes in turn to guarantee even pressure and maximum grip. Suitable for use on machine tools and all types of industrial power tools. Supplied with key. Manufactured to DIN 6349.



\* Primarily for use with hand operated machines. † Not suitable for reversing drills.

| Capacity (mm) | Mounting   | Maximum Diameter | Weight each | Order Code KEN-440 | List Price/1 | Offer Price/1 |
|---------------|------------|------------------|-------------|--------------------|--------------|---------------|
| 0.5 - 4       | 0JT        | 26.0             | 110g        | -1060K             | £48.64       | £35.51        |
| 0.5 - 6.5     | 1JT        | 30.0             | 140g        | -1110K             | £28.81       | £21.03        |
| 0.5 - 6.5     | 3/8"-24F † | 30.0             | 140g        | -1160K             | £28.81       | £21.03        |
| 1.0 - 10.0    | 2JT        | 42.7             | 430g        | -1320K             | £36.58       | £26.70        |
| 1.0 - 10.0*   | 3/8"-24F † | 38.0             | 270g        | -1360K             | £36.58       | £26.70        |
| 1.0 - 10.0*   | 1/2"-20F † | 38.0             | 270g        | -1380K             | £36.58       | £26.70        |
| 1.0 - 10.0    | 1/2"-20F † | 42.7             | 420g        | -1390K             | £37.51       | £27.38        |
| 0.8 - 10.0    | DIN-B12    | 42.7             | 400g        | -5020K             | £27.89       | £20.36        |
| 1.0 - 10.0    | DIN-B16    | 42.7             | 440g        | -5040K             | £29.63       | £21.63        |
| 1.0 - 13.0    | 2JT        | 52.0             | 760g        | -1420K             | £44.22       | £32.28        |
| 1.0 - 13.0    | 6JT        | 52.0             | 730g        | -1440K             | £44.22       | £32.28        |
| 1.0 - 13.0    | 33JT       | 52.0             | 740g        | -1450K             | £39.52       | £28.85        |
| 1.5 - 13.0    | DIN-B12    | 52.7             | 750g        | -5060K             | £34.03       | £24.84        |
| 1.0 - 13.0    | DIN-B16    | 52.7             | 780g        | -5080K             | £36.17       | £26.40        |
| 1.0 - 16.0    | 3JT        | 56.5             | 970g        | -1530K             | £52.93       | £38.64        |
| 1.5 - 13.0    | 1/2"-20F   | 42.8             | 270g        | -4640K             | £18.09       | £13.21        |
| 1.5 - 13.0    | 3/8"-24F † | 42.5             | 420g        | -1460K             | £39.52       | £28.85        |
| 1.5 - 13.0    | 1/2"-20F † | 46.0             | 530g        | -1480K             | £39.52       | £28.85        |
| 3.0 - 16.0    | DIN-B16    | 56.5             | 890g        | -5100K             | £40.52       | £29.58        |
| 3.0 - 16.0*   | 1/2"-20F † | 50.0             | 610g        | -1580K             | £45.28       | £33.05        |
| 5.0 - 20.0    | 3JT        | 65.0             | 1300g       | -1630K             | £73.42       | £53.60        |
| 5.0 - 20.0    | DIN-B22    | 65.0             | 1335g       | -5120K             | £62.05       | £45.30        |

## KOBE Drill Chuck

Fully hardened and ground for durability and wear resistance. Suitable for use with portable power tools. Supplied with key.



| Capacity (mm) | Mount      | Weight each | Order Code KBE-440 | List Price/1 | Offer Price/1 |
|---------------|------------|-------------|--------------------|--------------|---------------|
| 1.0 - 10.0    | 3/8" - 24M |             | -1510A             | £13.11       | £9.57         |
| 1.5 - 13.0    | 3/8" - 24M |             | -1520B             | £16.39       | £11.96        |
| 1.5 - 13.0    | 1/2" - 20M |             | -1530C             | £16.39       | £11.96        |

CONTRACT PRICES AVAILABLE FOR VOLUME PURCHASES

Workshop Equipment

# GROUP 440/441 CHUCKS/CHUCK KEYS

## Jacobs Stainless Steel Chuck **NEW**

1BM 3/8"

Suitable for special applications on either portable drills or stationary machine tools; they are mainly used in medical and chemical industries. Resists chemical corrosion. Reduces potential for hazardous sparking. Minimizes risk of ferrous contamination in sterile environment.

**Also Available: Self-tightening Stainless Steel Keyless Chucks** - automatically increases gripping force proportional to increased torque to prevent bit slippage.



| Model Number | Mount  | Capacity (mm) | Key | Weight each | Order Code JAC-440 | List Price/1 | Offer Price/1 |
|--------------|--------|---------------|-----|-------------|--------------------|--------------|---------------|
| 1BM          | 3/8-24 | 0-6mm         | K1M | 142g        | -2315E             | £109.63      | £89.90        |

### Pin Type Chuck

Equipped with a pin type positive drive and designed for medium or heavy duty portable, bench or floor mounted power tools. Industrial quality with fully hardened and ground working components which offers high accuracy, gripping power and durability. Each chuck has centre ground jaws for absolute straightness and alignment, through hardened sleeve teeth plus hardened nose and keyholes to provide wear resistance. The one piece sleeve eliminates crack between the driving teeth.



| Model Number | Mount | Capacity (mm) | Key | Weight each | Order Code JAC-440 | List Price/1 | Offer Price/1 |
|--------------|-------|---------------|-----|-------------|--------------------|--------------|---------------|
| 3PD          | 3JT   | 3 - 16        | K3  | 940g        | -2511M             | £87.65       | £71.87        |
| 36PD         | 3JT   | 5 - 20.3      | K4  | 1280g       | -2539R             | £73.77       | £60.49        |

### Hammer Chuck

Hammer capable.



| Model Number | Mount    | Capacity (mm) | Key | Weight each | Order Code JAC-440 | List Price/1 | Offer Price/1 |
|--------------|----------|---------------|-----|-------------|--------------------|--------------|---------------|
| 33BA         | 3/8 - 24 | 2 - 13        | K32 | 480g        | -2528E             | £39.71       | £32.56        |
| 33BA         | 1/2 - 20 | 2 - 13        | K32 | 480g        | -2529F             | £39.71       | £32.56        |
| 33BA         | 5/8 - 16 | 2 - 13        | K32 | 480g        | -2530G             | £39.71       | £32.56        |

### Ball Bearing Super Chuck

Designed for extra heavy duty drill applications such as industrial drilling machines, jig borers, milling machines, lathes, radials and CNC/NC machining centres. Each chuck features ball bearing construction to maximise the gripping force and accuracy, through hardened sleeve teeth plus hardened nose and key holes to provide wear resistance. The centre ground jaws are specially heat treated to ensure high gripping surface hardness.



| Model Number | Mount | Capacity (mm) | Key | Weight each | Order Code JAC-440 | List Price/1 | Offer Price/1 |
|--------------|-------|---------------|-----|-------------|--------------------|--------------|---------------|
| 11N          | 2JT   | 0.711-10      | K32 | 540g        | -2101B             | £84.37       | £69.18        |
| 14N          | 3JT   | 0.711-13      | K3  | 1080g       | -2102C             | £102.57      | £84.11        |
| 16N          | 3JT   | 3-16          | K4  | 1330g       | -2103D             | £125.53      | £102.93       |
| 18N          | 4JT   | 3-19          | K4  | 1870g       | -2104E             | £183.23      | £150.25       |
| 20N          | 5JT   | 10-25.4       | K5  | 2830g       | -2105F             | £234.90      | £192.62       |

## KOBE Chuck Keys



| Model Number | To Suit Drill Chuck | Weight each | Order Code KBE-441 | List Price/1 | Offer Price/1 |
|--------------|---------------------|-------------|--------------------|--------------|---------------|
| 10043KG      | 10mm                | 40g         | -2010A             | £1.35        | £1.08         |
| 10038KK      | 13mm                | 50g         | -2020B             | £1.35        | £1.08         |

## KENNEDY Chuck Keys

Suitable for use with all industrial keyed chucks (including Rohm\* and Jacobs).

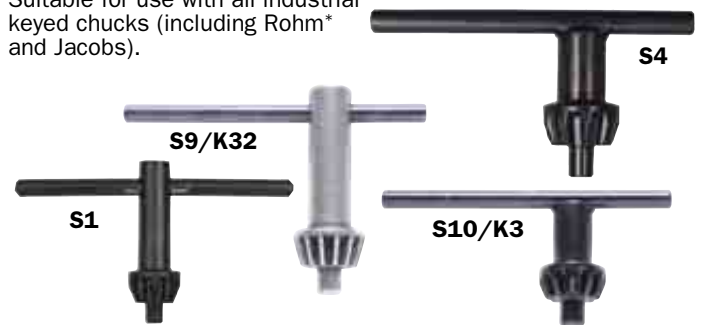

| Ref No. | For Use With Chuck Number   | Jacobs Equivalent | Weight each | Order Code KEN-441 | List Price/1 | Offer Price/1 |
|---------|---|-------------------|-------------|--------------------|--------------|---------------|
| S1      | 440-106/111/116 & 226<br>*4, 6, 6M & 8M   | -                 | 20g         | -0020K             | £2.83        | £2.26         |
| S2      | 440-132/136/138/139/146/148/236/237/238/246/247/248 & all Supercraft Chucks<br>*10S, 10, 10M, 13S & 13M | K8/10             | 50g         | -0040K             | £2.96        | £2.37         |
| S3      | 440-142/144/145/153 & 158   | -                 | 70g         | -0060K             | £3.02        | £2.42         |
| S4      | 440-163<br>*20 & 26   | -                 | 160g        | -0080K             | £5.58        | £4.46         |
| S7      | 1 Series  | K1                | 20g         | -0140K             | £2.29        | £1.83         |
| S8      | 31 Series & 8 1/2N  | K30S              | 50g         | -0160K             | £2.70        | £2.16         |
| S9      | 32 & 33 Series, 11N   | K32               | 60g         | -0180K             | £2.96        | £2.37         |
| S13     | 36 Series, 16, 18N  | K4                | 150g        | -0260K             | £5.68        | £4.54         |
| S14     | 1/4", 5/16", 3/8" Multicraft  | KG                | 20g         | -0280K             | £2.93        | £2.34         |
| S18     | 7 Series  | K7                | 30g         | -0360K             | £2.43        | £1.94         |
| S10     | 3 & 6 Series, 14N   | K3                | 90g         | -0400K             | £3.23        | £2.58         |
| K2      | 2 Series  | K2                | 40g         | -1020K             | £2.84        | £2.27         |

## Jacobs Chuck Keys



| Model No. | To Suit Chuck Number          | Handle Style | Order Code JAC-441 | List Price/1 | Offer Price/1 |
|-----------|-------------------------------|--------------|--------------------|--------------|---------------|
| K0        | 0                             | Bright Thumb | -2800A             | £2.85        | £2.56         |
| K1        | 1                             | Bright Thumb | -2801B             | £2.30        | £2.07         |
| K1M       | 1                             | Bright Thumb | -2801M             | £14.38       | £12.94        |
| K2        | 2                             | Bright Thumb | -2802C             | £2.85        | £2.56         |
| K3        |                               | Black Thumb  | -2803D             | £3.25        | £2.92         |
| K3B       | 3, 34, 34, 14N                | Bright Thumb | -2803H             | £3.66        | £3.29         |
| K4        | 36, 16, 18N                   | Bright Thumb | -2806G             | £5.70        | £5.13         |
| K5        | 20N                           | Bright Thumb | -2807H             | £24.15       | £21.73        |
| K7        | 7                             | Bright Thumb | -2808J             | £2.44        | £2.20         |
| K30S      | 31, 41, K13AC30, 8 1/2N       | Black Thumb  | -2804E             | £2.71        | £2.44         |
| K30B      | 31, 41, K13AC30,              | Bright Thumb | -2803L             | £3.12        | £2.81         |
| K32       | 32, 33, 11N                   | Black Thumb  | -2805F             | £2.98        | £2.68         |
| K32B      | 32, 33, 11N                   | Bright Thumb | -2805K             | £3.40        | £3.06         |
| KG        | K10ACG, Adaptadrive, DCG, SMG | Black Thumb  | -2809K             | £2.17        | £1.95         |
| S2        | Craft Chucks (8/10 metric)    | Black Thumb  | -2821B             | £2.71        | £2.44         |
| KK        | DC8, SM8                      | Black Thumb  | -2811M             | £2.85        | £2.56         |

Workshop Equipment



**KENNEDY Industrial**  
QUALITY INDUSTRIAL TOOLING® **Drill Chuck Arbors**

Precision machined, fully hardened and ground to give maximum surface contact.

**Morse Taper Drive to Threaded**



| Description      | Overall Length | Weight each | Order Code KEN-442 | List Price/1 | Offer Price/1 |
|------------------|----------------|-------------|--------------------|--------------|---------------|
| No.1 MT 1/2 x 20 | 92mm           | 100g        | -1120K             | £24.29       | £19.92        |
| No.1 MT 3/8 x 24 | 95mm           | 80g         | -1380K             | £24.29       | £19.92        |
| No.2 MT 1/2 x 20 | 105mm          | 170g        | -2120K             | £28.08       | £23.03        |
| No.2 MT 3/8 x 24 | 105mm          | 170g        | -2380K             | £28.08       | £23.03        |
| No.2 MT 5/8 x 16 | 105mm          | 180g        | -2580K             | £28.08       | £23.03        |
| No.3 MT 1/2 x 20 | 125mm          | 360g        | -3120K             | £31.57       | £25.89        |
| No.3 MT 3/8 x 16 | 125mm          | 370g        | -3580K             | £31.57       | £25.89        |

**KD Type - Morse Taper Shank to Din Taper Arbors**

Fully hardened and ground Morse Taper to **DIN 228**. Chuck taper to **DIN 238**.



| Morse Taper | Chuck Taper | Overall length | Order Code KEN-442 | List Price/1 | Offer Price/1 |
|-------------|-------------|----------------|--------------------|--------------|---------------|
| No.2 MT     | B12         | 106.5mm        | -5220K             | £8.48        | £6.95         |
| No.2 MT     | B16         | 111.5mm        | -5260K             | £8.48        | £6.95         |
| No.3 MT     | B12         | 125.0mm        | -5320K             | £11.13       | £9.13         |
| No.3 MT     | B16         | 134.0mm        | -5360K             | £11.13       | £9.13         |
| No.4 MT     | B16         | 159.0mm        | -5420K             | £18.67       | £15.31        |
| No.4 MT     | B22         | 176.0mm        | -5460K             | £23.45       | £19.23        |

**Bridgeport Drive to Jacobs Taper**



| Description | Overall Length | Weight each | Order Code KEN-442 | List Price/1 | Offer Price/1 |
|-------------|----------------|-------------|--------------------|--------------|---------------|
| R8 x 1JT    | 130mm          | 420g        | -9610K             | £37.26       | £30.55        |
| R8 x 2JT    | 135mm          | 440g        | -9620K             | £37.26       | £30.55        |
| R8 x 3JT    | 145mm          | 510g        | -9630K             | £37.26       | £30.55        |
| R8 x 6JT    | 135mm          | 450g        | -9660K             | £37.26       | £30.55        |
| R8 x 33JT   | 135mm          | 460g        | -9690K             | £37.26       | £30.55        |

**KENNEDY Industrial**  
QUALITY INDUSTRIAL TOOLING® **Drill Chuck Arbors**

Precision machined, fully hardened and ground to give maximum surface contact.

**Morse Taper Drive to Jacobs Taper**



| Description    | Overall Length | Weight each | Order Code KEN-442 | List Price/1 | Offer Price/1 |
|----------------|----------------|-------------|--------------------|--------------|---------------|
| No.1 MT x 1JT  | 90mm           | 70g         | -9110K             | £7.84        | £6.43         |
| No.1 MT x 2JT  | 95mm           | 80g         | -9120K             | £7.84        | £6.43         |
| No.1 MT x 6JT  | 96mm           | 100g        | -9160K             | £7.84        | £6.43         |
| No.1 MT x 33JT | 95mm           | 90g         | -9190K             | £7.84        | £6.43         |
| No.2 MT x 1JT  | 100mm          | 150g        | -9210K             | £8.51        | £6.98         |
| No.2 MT x 2JT  | 105mm          | 160g        | -9220K             | £8.51        | £6.98         |
| No.2 MT x 3JT  | 115mm          | 220g        | -9230K             | £8.51        | £6.98         |
| No.2 MT x 4JT  | 125mm          | 370g        | -9240K             | £31.19       | £25.58        |
| No.2 MT x 6JT  | 110mm          | 180g        | -9260K             | £8.51        | £6.98         |
| No.2 MT x 33JT | 110mm          | 180g        | -9290K             | £8.63        | £7.08         |
| No.3 MT x 1JT  | 120mm          | 310g        | -9310K             | £10.54       | £8.64         |
| No.3 MT x 2JT  | 125mm          | 330g        | -9320K             | £10.54       | £8.64         |
| No.3 MT x 3JT  | 135mm          | 380g        | -9330K             | £10.54       | £8.64         |
| No.3 MT x 4JT  | 145mm          | 520g        | -9340K             | £16.06       | £13.17        |
| No.3 MT x 5JT  | 150mm          | 680g        | -9350K             | £34.41       | £28.22        |
| No.3 MT x 6JT  | 130mm          | 340g        | -9360K             | £10.54       | £8.64         |
| No.3 MT x 33JT | 125mm          | 340g        | -9390K             | £10.54       | £8.64         |
| No.4 MT x 2JT  | 135mm          | 700g        | -9420K             | £16.60       | £13.61        |
| No.4 MT x 3JT  | 160mm          | 730g        | -9430K             | £16.60       | £13.61        |
| No.4 MT x 4JT  | 170mm          | 860g        | -9440K             | £16.60       | £13.61        |
| No.4 MT x 5JT  | 175mm          | 1000g       | -9450K             | £34.41       | £28.22        |
| No.4 MT x 6JT  | 155mm          | 690g        | -9460K             | £16.60       | £13.61        |
| No.4 MT x 33JT | 155mm          | 680g        | -9490K             | £16.60       | £13.61        |
| No.5 MT x 3JT  | 190mm          | 1700g       | -9530K             | £53.31       | £43.71        |
| No.5 MT x 4JT  | 200mm          | 1600g       | -9540K             | £53.31       | £43.71        |
| No.5 MT x 5JT  | 210mm          | 1900g       | -9550K             | £53.31       | £43.71        |

**SDS Adaptor**

Complete with retaining screw for reserve action. Suitable for use in rotary mode only.



| Description | Overall Length | Weight each | Order Code KEN-442 | List Price/1 | Offer Price/1 |
|-------------|----------------|-------------|--------------------|--------------|---------------|
| SDS 1/2"x20 | 75mm           | 40g         | -9000K             | £17.71       | £14.52        |

**Jacobs Rubber Flex® Tap Chuck Collets**

Designed for use with the Jacobs Tap Chucks and are unique in providing at least twice the gripping power of a conventional split steel collet. Features include: Parallel jaw inserts exert uniform and accurate gripping over the collet length. Durable one-piece construction resists heat, coolants and cutting compounds. Steel jaw inserts precision ground and hardened to ensure maximum gripping accuracy and wear resistance.

\*J116 and J117 may be used as replacements for J112, J113, J114.

| Product Number | Capacity mm | Contact Length B | Cone Angle C | Outside Dia. D | Number of Inserts | Weight each | Order Code JAC-442 | List Price/1 | Offer Price/1 |
|----------------|-------------|------------------|--------------|----------------|-------------------|-------------|--------------------|--------------|---------------|
| J116*          | 2.4 - 4.5   | 12.0             | 26°          | 15.0           | 6                 | 4g          | -4116A             | £60.21       | £51.78        |
| J117*          | 4.5 - 6.5   | 12.0             | 26°          | 15.0           | 8                 | 3g          | -4117C             | £60.21       | £51.78        |
| J420           | 4.5 - 8.1   | 12.7             | 40°          | 23.9           | 6                 | 6g          | -4420E             | £52.89       | £45.49        |
| J421           | 3.5 - 6.5   | 12.7             | 40°          | 23.9           | 6                 | 6g          | -4421E             | £52.89       | £45.49        |
| J422           | 6.4 - 9.7   | 12.7             | 40°          | 23.9           | 6                 | 9g          | -4422F             | £52.89       | £45.49        |
| J423           | 2.3 - 4.6   | 12.7             | 40°          | 21.8           | 4                 | 9g          | -4423G             | £52.07       | £44.78        |
| J440           | 7.1 - 12.7  | 16.0             | 45°          | 32.9           | 4                 | 9g          | -4440H             | £60.75       | £52.24        |
| J441           | 4.5 - 9.7   | 16.0             | 45°          | 32.9           | 4                 | 9g          | -4441J             | £60.75       | £52.24        |
| J443           | 2.8 - 7.1   | 15.7             | 45°          | 30.0           | 4                 | 9g          | -4443K             | £59.39       | £51.08        |
| J445           | 10.0 - 15.0 | 16.0             | 22-23°       | 32.5           | 8                 | 15g         | -4445L             | £68.09       | £58.56        |
| J461           | 10.0 - 16.0 | 19.0             | 25°          | 44.5           | 9                 | 49g         | -4461M             | £90.33       | £77.68        |
| J462           | 16.0 - 23.0 | 19.0             | 25°          | 44.5           | 9                 | 36g         | -4462N             | £89.79       | £77.22        |

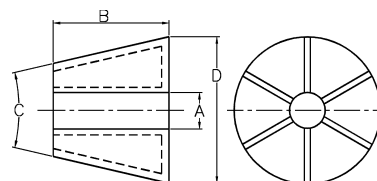

Indexa-Seiki fixed grip toggle clamps form a complete range suitable for countless applications including holding components in jigs and fixtures, clamping loads etc.

**Selection - Clamp Type**

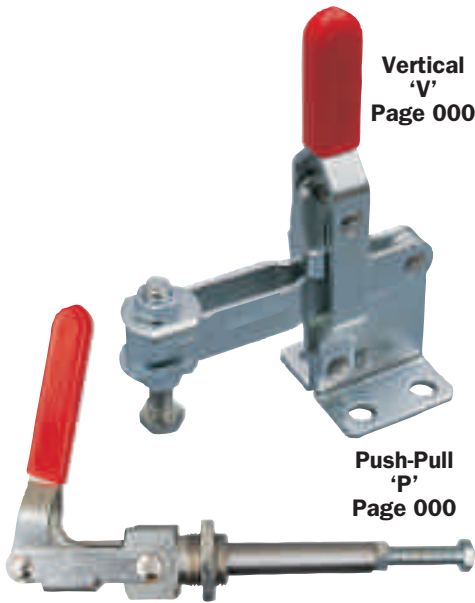

**Vertical 'V'**  
Page 000

**Push-Pull 'P'**  
Page 000

**Vertical**  
For general application in automotive and other heavy industries where trouble free life and robust construction are required. Force applied downward, 90° to bar.

**Horizontal**  
For general application in areas where a lower profile and unobstructiveness are required. Force applied downward, 90° to bar.

**Push-Pull**  
Clamps lock in extended and retracted positions. Force applied in line with spindle (straight line action).

**Latch**  
Suitable for applications such as sealing chamber doors, lids of mould closures. Latch bolts are threaded to allow easy adjustment.

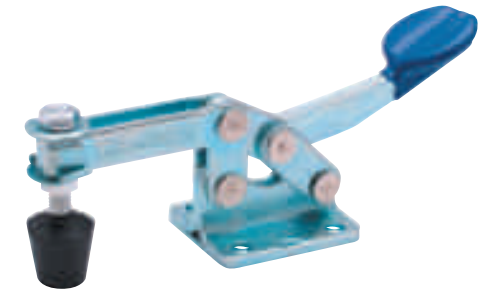

**Horizontal 'H'**  
Page 000

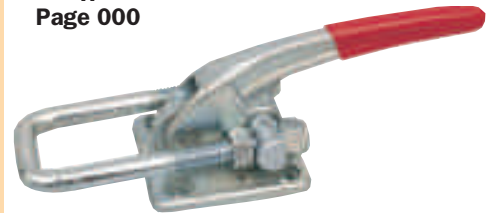

**Latch 'L'**  
Page 000

**Selection by Product Number**

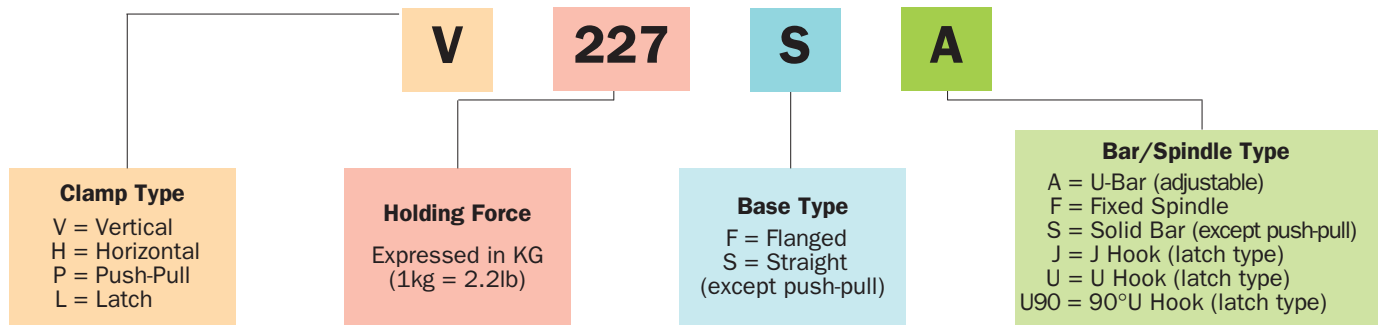

**Flanged 'F'**

**Selection - Base Type**

**Flanged**  
Suitable for bolting or welding the clamp on to a flat surface.

**Straight**  
Suitable for mounting on to an outside face or edge of workpiece.



**Straight 'S'**

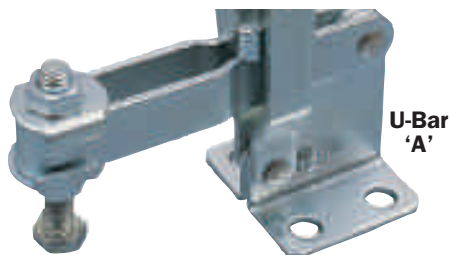

**U-Bar 'A'**

**Selection - Bar/Spindle Type**

**U-Bar**  
Clamping spindle can be adjusted along length of bar.

**Fixed Spindle**  
Clamping spindle is in a fixed position on the arm.

**Solid Bar**  
Clamping spindle and retainer are supplied loose to allow the arm to be cut to length and welded in desired position.

**Threaded Spindle**  
Used for push-pull type of clamp.

**U-Hook**  
Threaded for easy adjustment.

**J-Hook**  
Locks directly regardless of angle of hook.

**90° U Hook**  
Locks at 90° to clamp.



**Threaded Spindle 'handle position'**

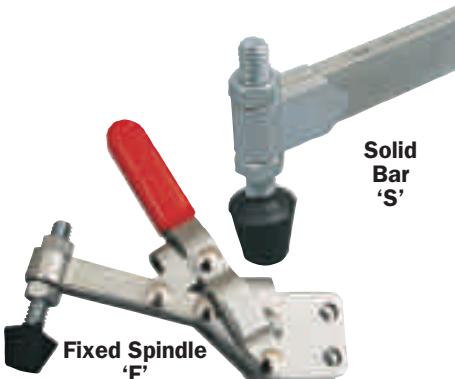

**Fixed Spindle 'F'**

**Solid Bar 'S'**

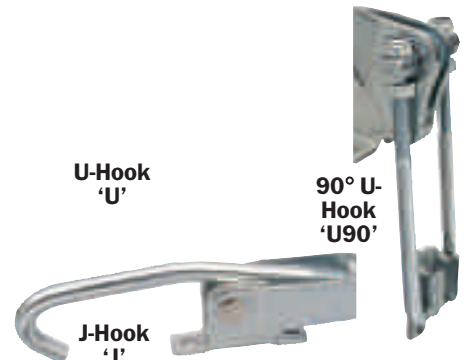

**U-Hook 'U'**

**90° U-Hook 'U90'**

**J-Hook 'J'**



# INDEXA Vertical Industrial Toggle Clamp

Designed to improve performance in fabrication and engineering clamping applications. The rapid clamping/unclamping made possible by the use of toggle clamps can greatly reduce machine/operator 'down-time' during all stages of production.

**Clamping Capacity** - the forces stated are the maximum loads that can be applied without causing permanent deformation. Due to leverage ratios, the holding capacity will be greatest at the point on the bar nearest to the handle of the clamp and forces stated have been achieved at this point.

### Vertical Clamp Dimensions (mm)

| Holding Capacity | A1 Flanged Base | A2 Straight Base | B1 Adj. Bar | B2 Fixed Bar | B3 Solid Bar | C Flanged Base | D    | E    | F Flanged Base | W    |
|------------------|-----------------|------------------|-------------|--------------|--------------|----------------|------|------|----------------|------|
| 50kg             | 75.0            | 83.8             | 24.5        | —            | —            | 19.0           | 25.4 | 15.9 | 33.3           | 5.2  |
| 90kg             | 95.2            | 107.1            | 33.2        | 33.2         | —            | 23.0           | 25.4 | 12.7 | 39.7           | 6.4  |
| 150kg            | 139.0           | 160.0            | 63.0        | —            | —            | 38.0           | 43.0 | 33.0 | 50.0           | 11.0 |
| 227kg            | 139.7           | 154.0            | 71.4        | —            | 57.2         | 31.8           | 34.9 | 31.8 | 46.0           | 8.3  |
| 300kg            | 285.0           | 330.0            | 120.0       | —            | —            | 50.0           | 60.0 | 30.0 | 77.0           | 13.5 |
| 450kg            | 225.4           | 257.5            | 125.4       | —            | —            | 50.8           | 50.8 | 31.8 | 64.2           | 13.5 |
| 550kg            | 304.8           | 352.4            | 153.0       | —            | 153.0        | 82.6           | 76.2 | 50.8 | 95.2           | 16.7 |

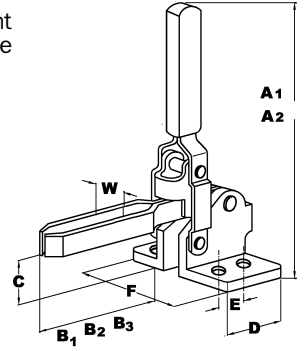

### 'U' Bar (Adjustable) Type

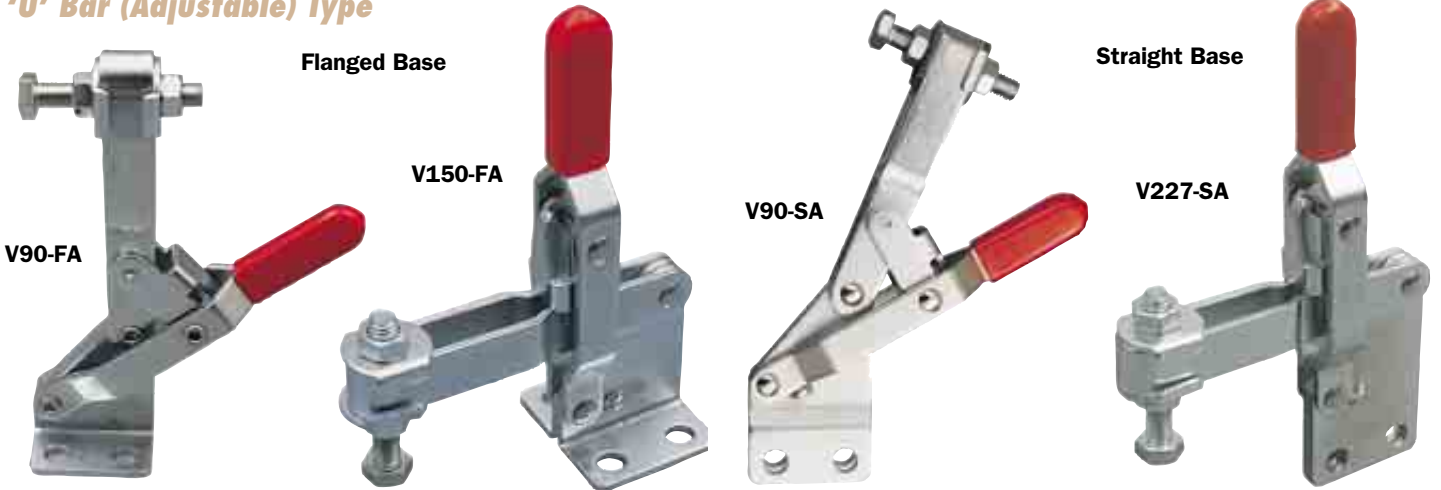

| Product Number | Holding Capacity | Movement |      | Base Type | Supplied With   | Weight each | Order Code IND-443 | List Price/1 | Offer Price/1 |
|----------------|------------------|----------|------|-----------|---|-------------|--------------------|--------------|---------------|
|                |                  | Handle   | Bar  |           |   |             |                    |              |               |
| V50-FA         | 50kg             | 56°      | 100° | Flanged   | Tipped Spindle (No.10) and Flanged Washer Spindle (1/4") and Flanged Washer | 60g         | -1020K             | £12.03       | £10.23        |
| V90-FA         | 90kg             | 60°      | 100° |           | Hex Head Spindle (M8) and Bolt Retainer                                     | 320g        | -1220K             | £13.80       | £11.73        |
| V150-FA        | 150kg            | 45°      | 94°  |           | Hex Head Spindle (M10) and Bolt Retainer                                    | 320g        | -1320K             | £13.64       | £11.59        |
| V227-FA        | 227kg            | 60°      | 100° |           | Tipped Spindle (5/16") and Flanged Washer                                   | 355g        | -1420K             | £17.05       | £14.49        |
| V300-FA        | 300kg            | 67°      | 140° |           | Hex Head Spindle (M10)  | 1250g       | -1620K             | £23.42       | £19.91        |
| V450-FA        | 450kg            | 70°      | 135° |           | Hex Head Spindle (1/2") and Flanged Washer                                  | 1140g       | -1720K             | £36.73       | £31.22        |
| V550-FA        | 550kg            | 60°      | 140° | Straight  | Hex Head Spindle (5/8") and Flanged Washer                                  | 2540g       | -1920K             | £43.88       | £37.30        |
| V340-FA        | 340kg            | 58°      | 105° |           | Tipped Spindle (3/8") and Flanged Washer                                    | 635g        | -1590K             | £23.16       | £19.69        |
| V50-SA         | 50kg             | 56°      | 100° |           | Tipped Spindle (No.10) and Flanged Washer Spindle (1/4") and Flanged Washer | 60g         | -1070K             | £12.03       | £10.23        |
| V90-SA         | 90kg             | 60°      | 100° |           | Spindle (1/4") and Flanged Washer   | 170g        | -1270K             | £15.19       | £12.91        |
| V150-SA        | 150kg            | 45°      | 94°  |           | Hex Head Spindle (M8) and Bolt Retainer                                     | 320g        | -1370K             | £13.64       | £11.59        |
| V227-SA        | 227kg            | 60°      | 100° |           | Tipped Spindle (5/16") and Flanged Washer                                   | 355g        | -1470K             | £16.52       | £14.04        |
| V300-SA        | 300kg            | 67°      | 140° | Straight  | Hex Head Spindle (M10)  | 1140g       | -1670K             | £23.42       | £19.91        |
| V450-SA        | 450kg            | 70°      | 135° |           | Hex Head Spindle (5/8") and Flanged Washer                                  | 1250g       | -1770K             | £36.34       | £30.89        |

### Fixed Spindle & Solid Bar Type



| Product Number | Holding Capacity | Movement |      | Base Type | Supplied With  | Weight each | Order Code IND-443 | List Price/1 | Offer Price/1 |
|----------------|------------------|----------|------|-----------|--|-------------|--------------------|--------------|---------------|
|                |                  | Handle   | Bar  |           |  |             |                    |              |               |
| V90-FF         | 90kg             | 60°      | 100° | Flanged   | Fixed Spindle (1/4")                                 | 170g        | -1120K             | £13.80       | £11.73        |
| V90-SF         | 90kg             | 60°      | 100° | Straight  | Fixed Spindle (1/4")                                 | 170g        | -1170K             | £13.80       | £11.73        |
| V227-FS        | 227kg            | 60°      | 100° | Flanged   | Solid Bar Hex Head (5/16") and Bolt Retainer*        | 340g        | -1520K             | £17.05       | £14.49        |
| V450-FS        | 450kg            | 70°      | 135° |           | Solid Bar Hex Head Spindle (1/2") and Bolt Retainer* | 1250g       | -1820K             | £36.73       | £31.22        |
| V550-FS        | 550kg            | 60°      | 140° |           | Solid Bar Hex Head Spindle (5/8") and Bolt Retainer* | 2540g       | -1940K             | £43.94       | £37.35        |
| V227-SS        | 227kg            | 60°      | 100° | Straight  | Solid Bar Tipped Spindle (5/16") and Bolt Retainer*  | 340g        | -1570K             | £17.05       | £14.49        |
| V450-SS        | 450kg            | 70°      | 135° |           | Solid Bar Hex Head Spindle (5/8") and Bolt Retainer* | 1250g       | -1870K             | £36.73       | £31.22        |

**CONTRACT PRICES AVAILABLE FOR VOLUME PURCHASES**

**GROUP 443 TOGGLE CLAMPS**

**INDEXA** Horizontal Industrial Toggle Clamp

With a low profile design suitable for use in applications requiring increased access to the actual workpiece. Available in eight sizes for general application in areas where a lower profile is required. Force applied downwards 90° to bar.

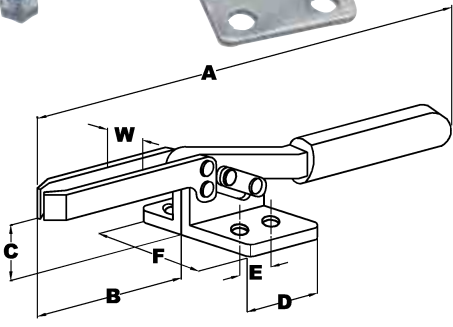
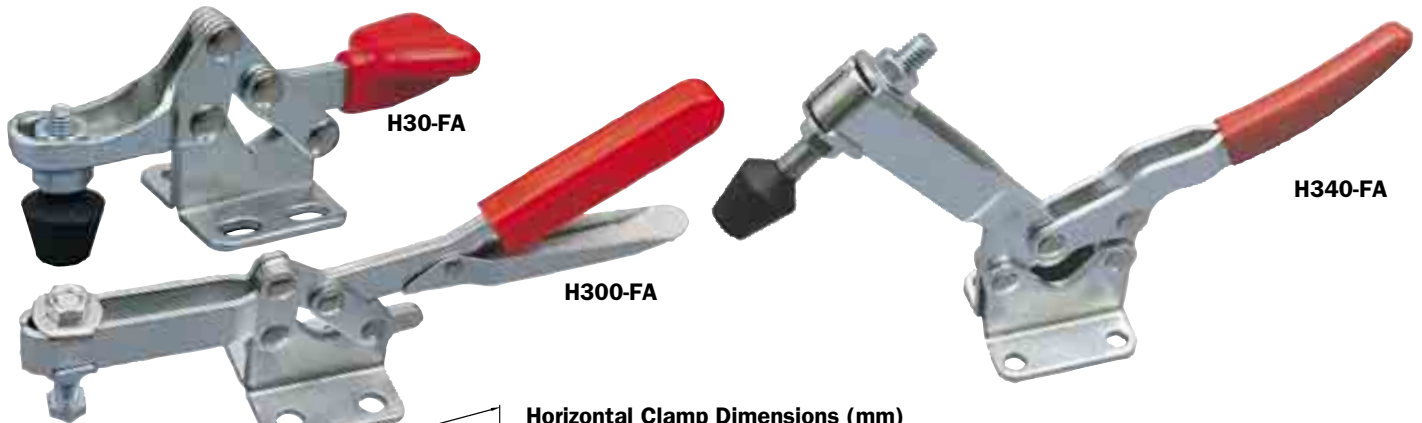

**Horizontal Clamp Dimensions (mm)**

| Holding Capacity | A     | B     | C    | D    | E    | F    | W    |
|------------------|-------|-------|------|------|------|------|------|
| 30kg             | 76.5  | 28.0  | 12.5 | 24.0 | 11.5 | 28.5 | 8.5  |
| 90kg             | 138.0 | 55.0  | 25.4 | 37.0 | 25.4 | 36.0 | 7.4  |
| 227kg            | 168.0 | 70.0  | 34.9 | 38.0 | 25.4 | 35.0 | 8.3  |
| 300kg            | 270.0 | 85.0  | 36.5 | 58.0 | 34.0 | 60.0 | 11.0 |
| 340kg            | 262.0 | 107.5 | 46.9 | 57.1 | 41.3 | 57.2 | 11.0 |
| 400kg            | 240.0 | 60.0  | 54.0 | 70.0 | 42.0 | 50.0 | 12.6 |
| 500kg            | 270.0 | 91.2  | 38.0 | 58.0 | 37.0 | 70.0 | 11.0 |
| 636kg            | 272.0 | 76.2  | 51.0 | 90.0 | 48.0 | 48.0 | 12.7 |

| Product Number | Holding Capacity | Movement Handle | Bar | Base Type  | Supplied with                                  | Weight each   | Order Code IND-443 | List Price/1  | Offer Price/1 |
|----------------|------------------|-----------------|-----|--|--|---------------|--------------------|---------------|---------------|
| H65-FA         | 75kg             | 76°             | 94° | Flanged  | Hex Head Spindle (M5) Moulded PVC Handles      | 100g          | <b>-1960K</b>      | £13.26        | <b>£11.27</b> |
| H86-FA         | 150kg            | 76°             | 94° |  | Hex Head Spindle (M6) Moulded PVC Handles      | 230g          | <b>-1970K</b>      | £16.93        | <b>£14.39</b> |
| H217-FA        | 250kg            | 76°             | 94° |  | Hex Head Spindle (M8) Moulded PVC Handles      | 430g          | <b>-1980K</b>      | £21.30        | <b>£18.11</b> |
| H30-FA         | 30kg             | 88°             | 80° |  | Tipped Spindle (M4)                            | 40g           | <b>-2020K</b>      | £10.67        | <b>£9.07</b>  |
| H90-FA         | 90kg             | 60°             | 85° |  | Tipped Spindle (1/4") and Flanged Washer       | 130g          | <b>-2120K</b>      | £16.63        | <b>£14.14</b> |
| H227-FA        | 227kg            | 65°             | 90° |  | Tipped Spindle (9/16") and Flanged Washer      | 255g          | <b>-2220K</b>      | £21.30        | <b>£18.11</b> |
| H300-FA        | 300kg            | 85°             | 80° |  | Hexagon Head Spindle (3/8") and Flanged Washer | 490g          | <b>-2320K</b>      | £23.74        | <b>£20.18</b> |
| H340-FA        | 340kg            | 50°             | 85° |  | Tipped Spindle (3/8") and Flanged Washer       | 640g          | <b>-2420K</b>      | £27.73        | <b>£23.57</b> |
| H400-FA        | 400kg            | 85°             | 84° | Tipped Spindle (3/8") and Flanged Washer         | 600g   | <b>-2520K</b> | £43.07             | <b>£36.61</b> |               |
| H500-FA        | 500kg            | 85°             | 65° | Hexagon Head Spindle (M10) and Flanged Washer    | 450g   | <b>-2620K</b> | £43.63             | <b>£37.09</b> |               |
| H636-FA        | 636kg            | 94°             | 91° | Hexagon Head Spindle (1/2") and Flanged Washer** | 1220g  | <b>-2720K</b> | £61.07             | <b>£51.91</b> |               |

\*\*Single mounting centre hole 13mm diameter for 'Tee' bolt mounting

**Latch Type Toggle Clamp**

Suitable for sealing chamber doors or mould closures. The latched bolts are threaded to allow easy adjustment and provide positive connection with latch plate.



**For Mould Release Sprays**

**See Group 732**

\*Optional latch plate IND-443-8000K

| Product Number | Holding Capacity | Drawing Movement | Drawing Adjust | Base Type | Description            | Weight each | Order Code IND-443 | List Price/1 | Offer Price/1  |
|----------------|------------------|------------------|----------------|-----------|------------------------|-------------|--------------------|--------------|----------------|
| L164-FU        | 164kg            | 30mm             | 9.9mm          | Flanged   | U-Style Bolt           | 80g         | <b>-4070K</b>      | £17.96       | <b>£15.27</b>  |
| L318-FU        | 318kg            | 45mm             | 9.6mm          |           | U-Style Bolt           | 225g        | <b>-4010K</b>      | £25.60       | <b>£21.76</b>  |
| L900-FU        | 900kg            | 80mm             | 23.8mm         |           | U-Style Bolt           | 680g        | <b>-4130K</b>      | £35.81       | <b>£30.44</b>  |
| L1818-FU       | 1818kg           | 88.9mm           | 19mm           | Flanged   | U-Style Bolt*          | 1260g       | <b>-4170K</b>      | £78.48       | <b>£66.71</b>  |
| L3400-FU       | 3400kg           | 55.6mm           | 28.6mm         |           | U-Style Bolt*          | 1480g       | <b>-4210K</b>      | £124.86      | <b>£106.13</b> |
| L170-FJ        | 170kg            | 100mm            | 6.5mm          |           | J-Style Bolt           | 270g        | <b>-4030K</b>      | £20.27       | <b>£17.23</b>  |
| L170-FJ        | 170kg            | 105mm            | 35mm           | Flanged   | J-Style Bolt           | 255g        | <b>-4050K</b>      | £20.12       | <b>£17.10</b>  |
| L340-FJ        | 340kg            | 140mm            | 40mm           |           | J-Style Bolt           | 340g        | <b>-4190K</b>      | £21.75       | <b>£18.49</b>  |
| L225-FU90      | 225kg            | 25mm             | 15mm           |           | 90° Angle U-Style Bolt | 113g        | <b>-4090K</b>      | £19.39       | <b>£16.48</b>  |
| L450-FU90      | 450kg            | 65mm             | 33mm           | Flanged   | 90° Angle U-Style Bolt | 250g        | <b>-4110K</b>      | £28.42       | <b>£24.16</b>  |
| L900-FU90      | 900kg            | 45mm             | 40mm           |           | 90° Angle U-Style Bolt | 700g        | <b>-4150K</b>      | £36.07       | <b>£30.66</b>  |

Workshop Equipment



**INDEXA** Push Pull Industrial Toggle Clamp

The straight line action which gives these plunger-style clamps extremely high loading capacities whilst maintaining compactness. These clamps also lock in the open position which allows a 'pull' to be exerted (for instance, in use with foam moulds). All models have tapped spindles for use with adjustable spindles.

**Base Mounted Type (Flanged)**

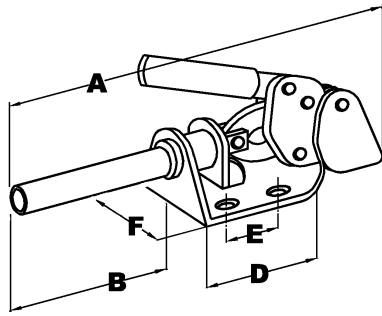

**Dimensions (mm)**

| Holding Capacity | A — Excluding Handle | B     | C    | D     | E              | F     |
|------------------|----------------------|-------|------|-------|----------------|-------|
| 45kg             | 72.2                 | 38.9  | 9.5  | 33.3  | 15.0           | 27.0  |
| 50kg             | 71.9                 | 16.9  | 13.0 | 49.0  | 24.0           | 42.0  |
| 136kg            | 138.0                | 47.0  | 24.6 | 48.0  | 35.0           | 56.0  |
| 160kg            | 146.0                | 76.0  | 15.5 | 70.0  | 40.0           | 72.0  |
| 200kg            | 124.5                | 41.5  | 14.0 | 48.0  | 40.0           | 50.0  |
| 227kg            | 125.4                | 52.4  | 19.0 | 52.4  | 35.0           | 57.2  |
| 295kg            | 204.0                | 112.0 | 17.7 | 92.0  | 60.0           | 83.0  |
| 386kg            | 158.8                | 81.0  | 23.8 | 58.8  | 41.4           | 57.2  |
| 680kg            | 238.2                | 120.8 | 35.0 | 73.2  | 50.8           | 71.4  |
| 1136kg           | 178.6                | 50.8  | 12.5 | 127.8 | 34.9           | 56.2  |
| 1136kg           | 178.6                | 50.8  | 12.5 | 127.8 | 41.3 (6 holes) | 56.2  |
| 1600kg           | 310.0                | 87.0  | 47.0 | 227.0 | 80.0           | 107.0 |

| Product Number | Holding Capacity | Spindle Thread     | Handle Movement | Handle Position | Base Type | Supplied With        | Weight each | Order Code IND-443 | List Price/1 | Offer Price/1 |
|----------------|------------------|--------------------|-----------------|-----------------|-----------|----------------------|-------------|--------------------|--------------|---------------|
| P45-F45        | 45kg             | 1/4" UNC x 12 Deep | 190°            |                 |           | Nylon Spindle        | 50g         | -3030K             | £11.74       | £9.98         |
| P136-F45       | 136kg            | M8                 | 180°            |                 |           | Hexagon Head Spindle | 300g        | -3060K             | £24.71       | £21.00        |
| P200-F45       | 180kg            | M8 x 1.25          | 144.5°          |                 |           | Hexagon Head Spindle | 345g        | -3090K             | £30.84       | £26.21        |
| P180-FA        | 180kg            | M8 x 1.25          | 145°            |                 |           | Hexagon Head Spindle | 35g         | -3100K             | £30.84       | £26.21        |
| P227-F45       | 227kg            | M8                 | 180°            | 45°             | Flanged   | Hexagon Head Spindle | 340g        | -3120K             | £26.65       | £22.65        |
| P386-F45       | 386kg            | M10                | 180°            | Extended        | Flanged   | Hexagon Head Spindle | 580g        | -3180K             | £41.85       | £35.57        |
| P680-F45       | 680kg            | M12                | 180°            |                 |           | Hexagon Head Spindle | 1480g       | -3240K             | £65.91       | £56.02        |
| P1136-F45      | 1136kg           | M10                | 180°            |                 |           | Hexagon Head Spindle | 935g        | -3300K             | £62.19       | £52.86        |
| P1600-F45      | 1600kg           | M8 x 1.25          | 180°            |                 |           | Hexagon Head Spindle |             | -3330K             | £80.62       | £68.53        |
| P227-F90       | 227kg            | M8 x 30 Deep       | 180°            | 90°             | Flanged   | Hexagon Head Spindle | 340g        | -3150K             | £26.65       | £22.65        |
| P386-F90       | 386kg            | M10 x 40 Deep      | 180°            | Extended        | Flanged   | Hexagon Head Spindle | 580g        | -3210K             | £31.03       | £26.38        |
| P680-F90       | 680kg            | M12 x 50 Deep      | 180°            |                 |           | Hexagon Head Spindle | 1480g       | -3270K             | £46.85       | £39.82        |
| P50-180F       | 50kg             | M5                 | 66°             | 180°            | Flanged   | Hexagon Head Spindle | 100g        | -3700K             | £16.63       | £14.14        |
| P386-180F      | 160kg            | M10                | 45°             | Extended        | Flanged   | Hexagon Head Spindle | 454g        | -3730K             | £20.75       | £17.64        |
| P680-180F      | 295kg            | 1/2" UNC           | 45°             |                 |           | Hexagon Head Spindle | 1270g       | -3760K             | £32.72       | £27.81        |

**Collar Mounted Type (Threaded)**

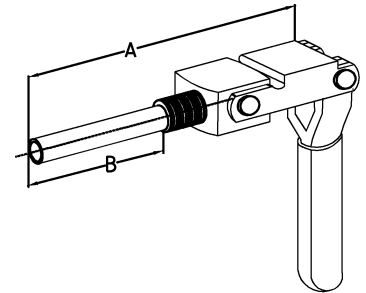
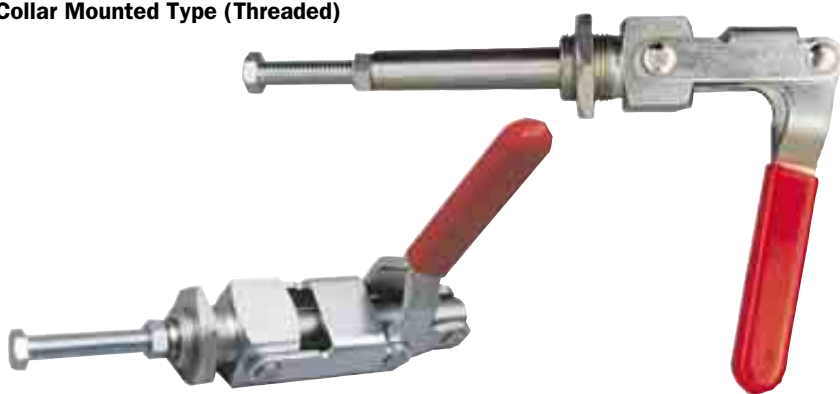

**Dimensions (mm)**

| Holding Capacity | A — Excluding Handle | B    |
|------------------|----------------------|------|
| 91kg             | 30.3                 | 20.6 |
| 136kg            | 115.0                | 37.7 |
| 318kg            | 169.5                | 65.3 |

| Product Number | Holding Capacity | Spindle Thread | Collar Thread | Handle Movement | Base Type | Supplied with        | Weight each | Order Code IND-443 | List Price/1 | Offer Price/1 |
|----------------|------------------|----------------|---------------|-----------------|-----------|----------------------|-------------|--------------------|--------------|---------------|
| P91-FT         | 91kg             | 1/4" UNC       | M16           | 180°            |           | Nylon Spindle        | 113g        | -3530K             | £27.31       | £23.21        |
| P136-FT        | 136kg            | 5/16" UNC      | M20           | 180°            | Flanged   | Hexagon Head Spindle | 270g        | -3560K             | £35.02       | £29.77        |
| P318-FT        | 318kg            | 3/8" UNC       | M27           | 180°            |           | Hexagon Head Spindle | 690g        | -3590K             | £47.90       | £40.72        |

**CONTRACT PRICES AVAILABLE FOR VOLUME PURCHASES**

All Prices Exclude V.A.T. © 2011

Workshop Equipment

**GROUP 443 TOGGLE CLAMPS**

**ATLAS WORKHOLDERS Vertical Industrial Toggle Clamp**

Designed to improve performance in fabrication and engineering clamping applications. The rapid clamping/unclamping made possible by the use of toggle clamps can greatly reduce machine/operator 'down-time' during all stages of production.

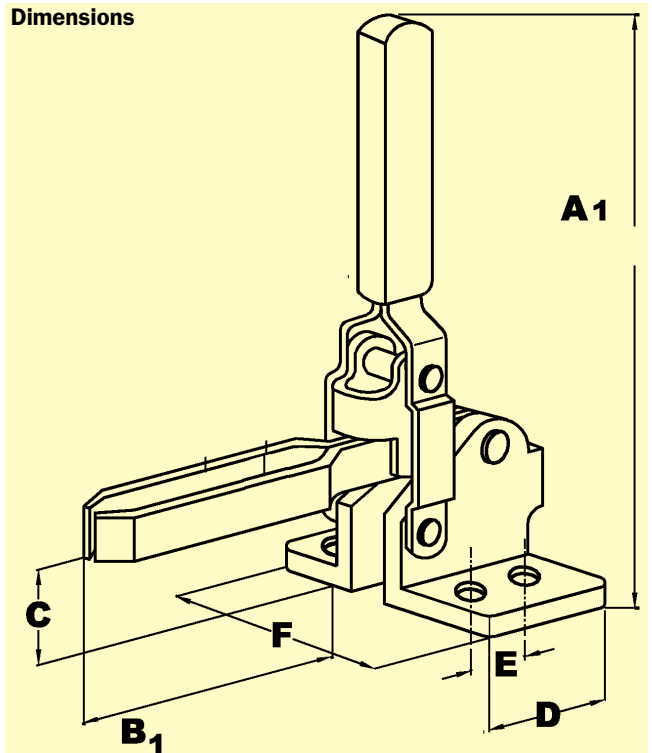

**'U' Bar (Adjustable) Type with Flanged Base**

| Product Number | A <sub>1</sub> Flanged Base | B <sub>1</sub> Flanged Base | C Flanged Base | D    | E    | F Flanged Base |
|----------------|-----------------------------|-----------------------------|----------------|------|------|----------------|
| AV50-FA        | 75.0                        | 24.5                        | 19.0           | 25.4 | 15.9 | 39.7           |
| AV90-FA        | 93.0                        | 39.0                        | 23.0           | 29.0 | 14.0 | 28.0           |
| AV150-FA       | 143.0                       | 44.0                        | 31.0           | 19.0 | 12.7 | 42.0           |
| AV200-FA       | 139.0                       | 63.0                        | 38.0           | 43.0 | 24.0 | 50.0           |
| AV217-FA       | 139.7                       | 71.4                        | 31.8           | 34.9 | 19.0 | 46.0           |
| AV450-FA       | 272.0                       | 125.0                       | 62.0           | 70.0 | 40.0 | 70.0           |

**Fixed Spindle Type with Flanged Base**

| Product Number | A <sub>1</sub> Flanged Base | B <sub>1</sub> Flanged Base | C Flanged Base | D    | E    | F Flanged Base |
|----------------|-----------------------------|-----------------------------|----------------|------|------|----------------|
| AV80-FF        | 100.0                       | 27.0                        | 23.8           | 25.4 | 12.7 | 39.7           |
| AV217-FS       | 139.7                       | 57.2                        | 31.8           | 34.9 | 19.0 | 46.0           |

**For Mould Release Sprays**

**See Group 732**

Workshop Equipment

**'U' Bar (Adjustable) Type with Flanged Base**

| Product Number | Holding Capacity | Movement |      | Base Type | Supplied With                              | Weight each | Order Code <b>ATL-443</b> | List Price/1 | Offer Price/1 |
|----------------|------------------|----------|------|-----------|--|-------------|---------------------------|--------------|---------------|
|                |                  | Handle   | Bar  |           |  |             |                           |              |               |
| AV50-FA        | 50kg             | 56°      | 100° | Flanged   | Tipped Spindle (M5) and Flanged Washers    | 60g         | <b>-1020K</b>             | £10.83       | <b>£9.21</b>  |
| AV90-FA**      | 90kg             | 60°      | 100° |           | Spindle (M6) and Bolt Retainer             | 115g        | <b>-1220K</b>             | £12.42       | <b>£10.56</b> |
| AV150-FA       | 150kg            | 70°      | 108° |           | Hex Head Spindle (M6) Moulded PVC Handle   | 230g        | <b>-1970K</b>             | £15.24       | <b>£12.95</b> |
| AV200-FA       | 200kg            | 45°      | 94°  |           | Hex Head Spindle (M8) and Flanged Washers  | 370g        | <b>-1320K</b>             | £12.28       | <b>£10.44</b> |
| AV217-FA       | 217kg            | 60°      | 100° |           | Tipped Spindle (M8) and Flanged Washers    | 310g        | <b>-1420K</b>             | £15.34       | <b>£13.04</b> |
| AV450-FA       | 450kg            | 70°      | 135° |           | Hex Head Spindle (M12) and Flanged Washers | 1220g       | <b>-1720K</b>             | £33.06       | <b>£28.10</b> |

\*\* Model AV90-FA has Side Flange - All other FA models listed have Flat Flanges

**Fixed Spindle Type with Flanged Base**

| Product Number | Holding Capacity | Movement |      | Base Type | Supplied With                     | Weight each | Order Code <b>ATL-443</b> | List Price/1 | Offer Price/1 |
|----------------|------------------|----------|------|-----------|-----------------------------------|-------------|---------------------------|--------------|---------------|
|                |                  | Handle   | Bar  |           |                                   |             |                           |              |               |
| AV80-FF        | 90kg             | 60°      | 100° | Flanged   | Fixed Spindle (M8)                | 170g        | <b>-1120K</b>             | £12.42       | <b>£10.56</b> |
| AV217-FS       | 217kg            | 60°      | 100° |           | Solid Bar and Bolt Retainer (M8)* | 310g        | <b>-1520K</b>             | £15.34       | <b>£13.04</b> |

\* Please Note that the bolt retainer supplied needs to be welded in to position by the user



**ATLAS** *Horizontal Industrial Toggle Clamps*  
WORKHOLDERS

With a low profile design suitable for use in applications requiring increased access to the actual workpiece. Available in eight sizes for general application in areas where a lower profile is required. Force applied downwards 90° to bar.

**'U' Bar (Adjustable) Type with Flanged Base**



AH250-FA



AH20-FA



AH340-FA



AH80-FA

**Dimensions**

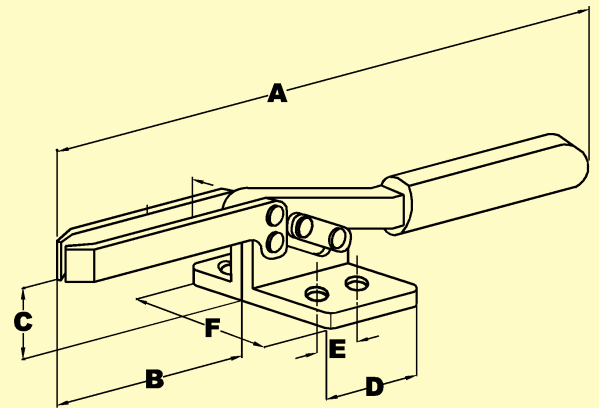

| Product Number | A     | B     | C    | D    | E    | F    |
|----------------|-------|-------|------|------|------|------|
| AH20-FA        | 110.0 | 37.5  | 24.8 | 36.5 | 24.0 | 30.0 |
| AH80-FA        | 138.1 | 55.0  | 25.4 | 36.5 | 25.4 | 38.0 |
| AH217-FA       | 168.0 | 70.0  | 34.9 | 38.0 | 53.4 | 35.0 |
| AH250-FA       | 274.0 | 108.0 | 45.0 | 59.0 | 41.2 | 59.0 |
| AH340-FA       | 263.5 | 108.0 | 44.4 | 57.2 | 41.3 | 57.2 |

| Product Number | Holding Capacity | Movement Handle | Movement Bar | Base Type | Supplied with                                  | Weight each | Order Code    | List Price/1 | Offer Price/1 |
|----------------|------------------|-----------------|--------------|-----------|--|-------------|---------------|--------------|---------------|
| AH20-FA        | 30kg             | 88°             | 80°          | Flanged   | Tipped Spindle (M6) and Flanged Washers        | 100g        | <b>-2020K</b> | £9.60        | <b>£8.16</b>  |
| AH80-FA        | 80kg             | 60°             | 85°          |           | Tipped Spindle (M6) and Flanged Washers        | 130g        | <b>-2120K</b> | £14.97       | <b>£12.72</b> |
| AH217-FA       | 217kg            | 65°             | 90°          |           | Tipped Spindle (M8) and Flanged Washers        | 312g        | <b>-2220K</b> | £19.17       | <b>£16.29</b> |
| AH250-FA       | 250kg            | 94°             | 76°          |           | Hexagon Head Spindle (M10) and Flanged Washers | 500g        | <b>-2620K</b> | £39.27       | <b>£33.38</b> |
| AH340-FA       | 340kg            | 50°             | 85°          |           | Tipped Spindle (M10) and Flanged Washers       | 265g        | <b>-2420K</b> | £24.95       | <b>£21.21</b> |

**Latch Type Toggle Clamps**

Suitable for sealing chamber doors or mould closures. The latched bolts are threaded to allow easy adjustment and provide positive connection with latch plate.

**'U' Style Bolt Type with Flanged Base**

AL165-FU

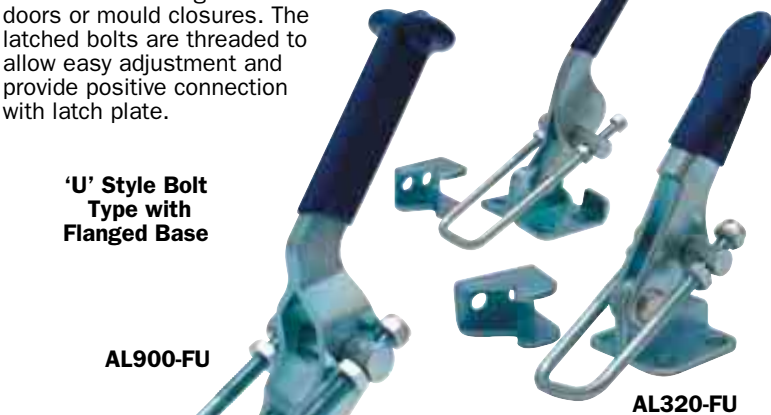

AL900-FU

AL320-FU

**Dimensions**

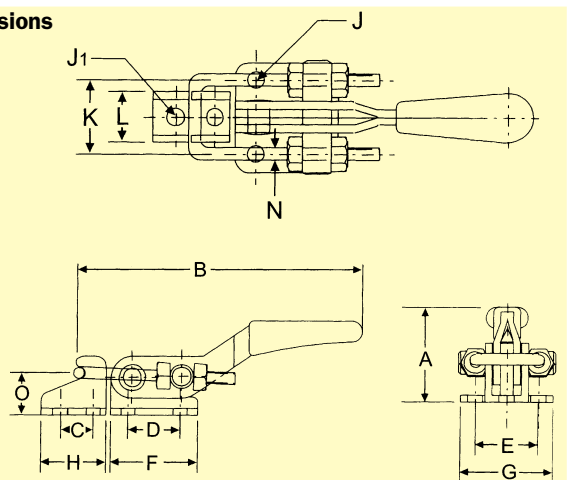

| Product Number | A    | B     | C   | D    | E    | F    | G    | H  | J   | J <sub>1</sub> | K    | L    | N   | O  |
|----------------|------|-------|-----|------|------|------|------|----|-----|----------------|------|------|-----|----|
| AL165-FU       | 36   | 88    | 9.9 | 16   | 19   | 26   | 28   | 45 | 4.3 | 4.3            | 19   | 13.2 | 3.3 | 12 |
| AL320-FU       | 45   | 151.6 | 14  | 19   | 31.8 | 39.6 | 44.5 | 25 | 6.8 | 6.8            | 25.4 | 17.5 | 4   | 17 |
| AL900-FU       | 70.6 | 190   | 19  | 41.4 | 38   | 60.5 | 54   | 38 | 8.4 | 8.4            | 44.5 | 30.0 | 8   | 24 |

| Product Number | Holding Capacity | Drawing Movement | Drawing Adjust | Base Type | Description  | Weight each | Order Code    | List Price/1 | Offer Price/1 |
|----------------|------------------|------------------|----------------|-----------|--------------|-------------|---------------|--------------|---------------|
| AL165-FU       | 165kg            | 30mm             | 9.9mm          | Flanged   | U-Style Bolt | 68g         | <b>-4070K</b> | £16.17       | <b>£13.74</b> |
| AL320-FU       | 320kg            | 45mm             | 9.6mm          |           | U-Style Bolt | 225g        | <b>-4010K</b> | £23.03       | <b>£19.58</b> |
| AL900-FU       | 900kg            | 80mm             | 23.8mm         |           | U-Style Bolt | 650g        | <b>-4130K</b> | £32.23       | <b>£27.40</b> |

**CONTRACT PRICES AVAILABLE FOR VOLUME PURCHASES**

**GROUP 443 TOGGLE CLAMPS**

**ATLAS WORKHOLDERS** *Push Pull Industrial Toggle Clamps*

The straight line action which gives these plunger-style clamps extremely high loading capacities whilst maintaining compactness. These clamps also lock in the open position which allows a 'pull' to be exerted (for instance, in use with foam moulds). All models have tapped spindles for use with adjustable spindles.

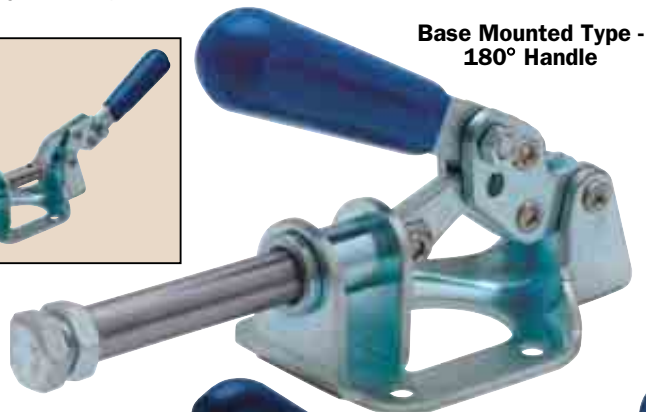

**Base Mounted Type - 180° Handle**

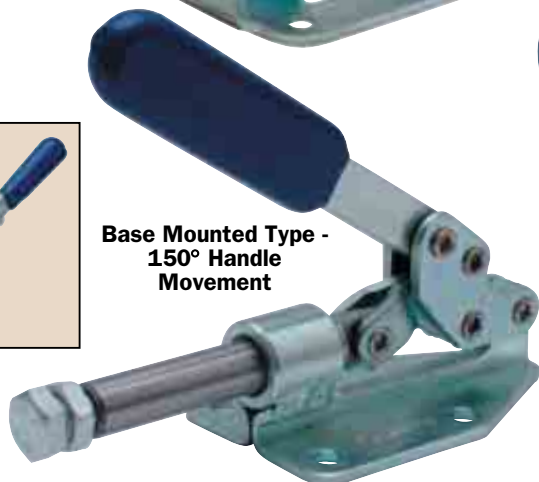

**Base Mounted Type - 150° Handle Movement**



**Base Mounted Type - 190° Handle Movement**

**Dimensions**

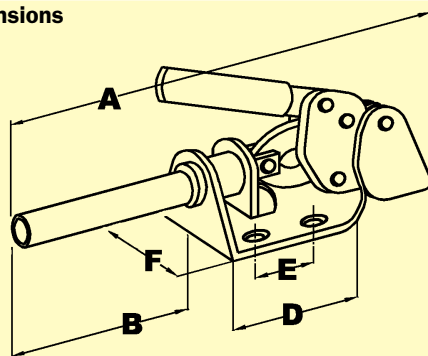

| Product Number | A—Excl. Handle | B    | C    | D    | E    | F    |
|----------------|----------------|------|------|------|------|------|
| AP136          | 138.1          | 49.2 | 24.6 | 88.9 | 34.9 | 55.6 |
| AP200          | 124.5          | 41.5 | 14.0 | 83.0 | 40.0 | 50.0 |
| AP227          | 151.0          | 63.0 | 15.0 | 88.0 | 32.0 | 63.0 |



| Product Number | Holding Capacity | Spindle Thread | Handle Movement | Handle Position | Base Type | Supplied With        | Weight each | Order Code    | List Price/1 | Offer Price/1 |
|----------------|------------------|----------------|-----------------|-----------------|-----------|----------------------|-------------|---------------|--------------|---------------|
| AP136          | 136kg            | M8             | 180°            |                 |           | Hexagon Head Spindle | 285g        | <b>-3060K</b> | £22.23       | <b>£18.90</b> |
| AP200          | 200kg            | M8 x 1.25      | 150°            | 45°             | Flanged   | Hexagon Head Spindle | 330g        | <b>-3090K</b> | £27.76       | <b>£23.60</b> |
| AP227          | 227kg            | M8 x 30 Deep   | 190°            | Extended        |           | Hexagon Head Spindle | 540g        | <b>-3150K</b> | £23.98       | <b>£20.38</b> |

Workshop Equipment

**INDEXA** *Heavy Duty Weldable Toggle Clamps*



Hold down action suitable for high production automotive type applications. Heavy duty forged components with hardened and ground pivot points. The users provide their own handle and bar and weld them to the clamp which is then welded to a base. The flexible mounting of these clamps allows them to be used in situations where standard clamps are not effective.



| Holding Capacity | Base Clamp Width | Clamp Height with Handle | Weight each | Order Code    | Offer Price/1 |
|------------------|------------------|--------------------------|-------------|---------------|---------------|
| 700kg            | 28mm             | 110mm                    | 808g        | <b>-5010K</b> | <b>£49.34</b> |
| 700kg            | 45mm             | 130mm                    | 915g        | <b>-5030K</b> | <b>£46.76</b> |
| 1100kg           | 35mm             | 140mm                    | 1468g       | <b>-5050K</b> | <b>£59.38</b> |
| 1100kg           | 50mm             | 170mm                    | 1574g       | <b>-5070K</b> | <b>£50.41</b> |
| 2200kg           | 50mm             | 170mm                    | 2749g       | <b>-5090K</b> | <b>£70.16</b> |
| 2200kg           | 63mm             | 205mm                    | 2881g       | <b>-5110K</b> | <b>£68.72</b> |

**BRAUER** *Heavy Duty Push-Pull Clamps*

**Features:** These clamps are of exceptionally robust construction featuring cast and machined handles and bases. Clamps are designed with a low plunger height and with the mechanism guarded within the base to avoid finger traps.

**Specification:** The bases of all models are machined S.G. iron castings. The plungers are of steel, and their precision ground diameter runs in a close-tolerance hole in the base casting. Handle movement 185°. All axles are of hardened steel and run in either the S.G. iron of the handle, or in the close-toleranced holes of hardened parts. All models are supplied with a steel set screw.



| Product Number | Holding Capacity | Weight each | Order Code    | Offer Price/1  |
|----------------|------------------|-------------|---------------|----------------|
| P600           | 600daN           | 0.45kg      | <b>-1204E</b> | <b>£34.01</b>  |
| P1200          | 1200daN          | 1.35kg      | <b>-1208J</b> | <b>£54.31</b>  |
| P2500          | 2500daN          | 3.60kg      | <b>-1213P</b> | <b>£88.60</b>  |
| P5000          | 5000daN          | 6.20kg      | <b>-1218V</b> | <b>£142.62</b> |
| P600L          | 600daN           | 0.55kg      | <b>-1204H</b> | <b>£44.90</b>  |
| P1200L         | 1200daN          | 1.60kg      | <b>-1209K</b> | <b>£68.32</b>  |
| P2500L         | 2500daN          | 4.15kg      | <b>-1214Q</b> | <b>£111.65</b> |

*Manual Toggle Press*

**Features:** S.G. Iron frame casting. Precision ground steel plunger. Fixed height work head

**Specification:** Bench mounted manual toggle press with comfortable, cushioned PVC orange handle grip.

**Clamp arm movement:** 185°

**P600P:**  
**Holding capacity:** 600daN.

**P1200PR:**  
**Holding capacity:** 1200daN.

**P2500PR:**  
**Holding capacity:** 2500daN.

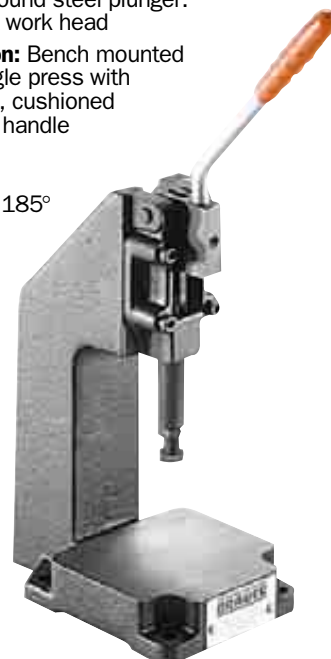

| Product Number | Weight each | Order Code    | Offer Price/1  |
|----------------|-------------|---------------|----------------|
| P600PR         | 3.60kg      | <b>-1205F</b> | <b>£178.87</b> |
| P1200PR        | 7.35kg      | <b>-1211F</b> | <b>£298.13</b> |
| P2500PR        | 15.50kg     | <b>-1215F</b> | <b>£425.06</b> |

## INDEXA Latch Plates

For use with latch type toggle clamps.



| Base Size | Hook Width | Order Code IND-443 | List Price/1 | Offer Price/1 |
|-----------|------------|--------------------|--------------|---------------|
| 80 x 55mm | 22mm       | -8000K             | £13.04       | £11.08        |

## Flanged Washers

For use in conjunction with all spindles on clamps with adjustable 'U' bars.



| To fit Spindle  | Weight each | Order Code IND-443 | List Price/1 | Offer Price/1 |
|-----------------|-------------|--------------------|--------------|---------------|
| 5/32" (No.8/M4) | 2g          | -8700K             | £0.51        | £0.43         |
| 3/16" (No.10)   | 2g          | -8720K             | £0.51        | £0.43         |
| 1/4"            | 4g          | -8740K             | £0.51        | £0.43         |
| 5/16" (M8)      | 10g         | -8780K             | £0.60        | £0.51         |
| 3/8" (M10)      | 15g         | -8800K             | £0.60        | £0.51         |
| 1/2"            | 37g         | -8820K             | £0.68        | £0.58         |
| 5/8"            | 49g         | -8840K             | £0.68        | £0.58         |

## Swivel Foot Spindles

As Neoprene capped but suitable for clamping onto irregular shapes or angled workpieces.

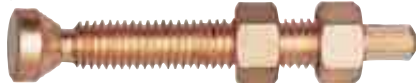

| Size      | Length | Weight each | Order Code IND-443 | List Price/1 | Offer Price/1 |
|-----------|--------|-------------|--------------------|--------------|---------------|
| 1/4" UNC  | 2 1/4" | 018g        | -8500K             | £3.31        | £2.81         |
| 5/16" UNC | 2 3/4" | 031g        | -8520K             | £3.80        | £3.23         |
| 3/8" UNC  | 3"     | 047g        | -8540K             | £4.45        | £3.78         |
| 1/2" UNC  | 4"     | 115g        | -8560K             | £4.92        | £4.18         |

## Neoprene Capped Spindles

For use with adjustable 'U' bar type clamps and solid bar type clamps that have bolt retainers.



| Size      | Length | Weight each | Order Code IND-443 | Offer Price/1 |
|-----------|--------|-------------|--------------------|---------------|
| M4 x 0.7  | 25mm   | 5g          | -8020K             | £1.16         |
| M8 x 1.25 | 63mm   | 34g         | -8100K             | £1.99         |
| M10 x 1.5 | 85mm   | 64g         | -8140K             | £2.27         |
| No 10UNC  | 1 3/8" | 9g          | -8200K             | £1.16         |
| 1/4" UNC  | 1 3/4" | 16g         | -8220K             | £1.34         |
| 5/16" UNC | 2 1/2" | 31g         | -8260K             | £1.50         |
| 3/8" UNC  | 3 1/2" | 58g         | -8300K             | £2.27         |
| 1/2" UNC  | 3 3/4" | 125g        | -8340K             | £2.43         |

## Neoprene Caps

For standard adjustable spindles.



| To fit Spindle | Weight each | Order Code IND-443 | List Price/1 | Offer Price/1 |
|----------------|-------------|--------------------|--------------|---------------|
| 1/4"           | 08g         | -8600K             | £0.77        | £0.65         |
| 5/16"          | 15g         | -8620K             | £0.90        | £0.77         |
| 3/8"           | 24g         | -8640K             | £1.15        | £0.98         |
| 1/2"           | 45g         | -8660K             | £1.20        | £1.02         |

## Cam Type Toggle G-Clamp (Pull Back Clamp)

To securely fix the clamp into position the base can be welded to the work surface.



| Holding Capacity | Jaw Opening | Jaw Movement | Handle Movement | Order Code IND-443 | Offer Price/1 |
|------------------|-------------|--------------|-----------------|--------------------|---------------|
| 340kg            | 45.2mm      | 90°          | 50°             | -5510K             | £26.97        |

## Toggle Pliers

Toggle pliers have the advantage of a pivoting jaw mechanism to allow a deep throat depth to open and close easily when clamping awkward profiles such as steel angle section. The jaw spindle can be pre-set to achieve the optimum clamping distance and pressure and so is most useful for repetitive clamping applications.

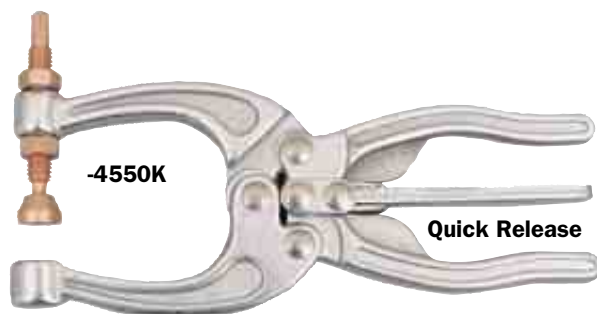

| Holding Capacity | Jaw Opening Min | Jaw Opening Max | Standard Spindle Supplied | Order Code IND-443 | Offer Price/1 |
|------------------|-----------------|-----------------|---------------------------|--------------------|---------------|
| 90kg             | 25.4            | 52.4            | Hex. Head                 | -4510K             | £18.41        |
| 159kg            | 31.8            | 65.1            | Hex. Head                 | -4530K             | £21.15        |
| 318kg            | 44.4            | 92.0            | Swivel                    | -4550K             | £34.27        |
| 318kg            | 76.2            | 123.8           | Hex. Head & Swivel        | -4570K             | £43.95        |

## 'Stub' Type Toggle Pliers

With two stub arms for easy linking to special jaw extensions.



| Holding Capacity | Closed Head Width (mm) | Overall Length | Order Code IND-443 | Offer Price/1 |
|------------------|------------------------|----------------|--------------------|---------------|
| 500kg            | 95.6                   | 156.1          | -4590K             | £37.42        |

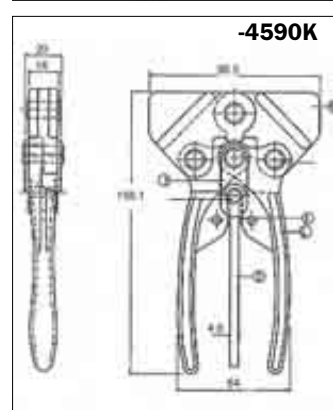
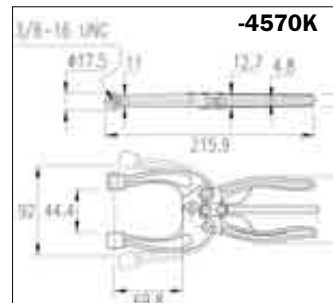
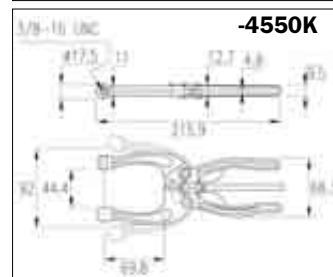
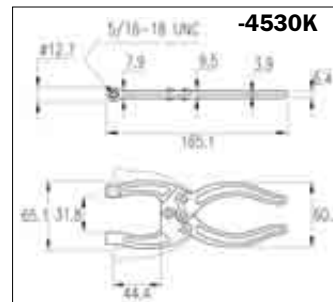
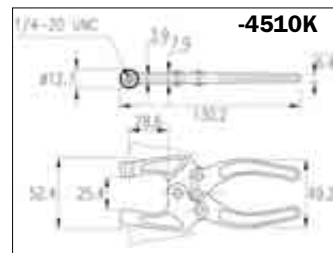
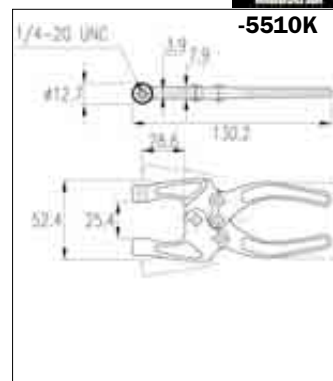

Workshop Equipment

**BRAUER**® *Vertical Industrial Clamp*

**Features:** Comfortable, cushioned PVC orange handle grips.

**Specification:** The main components are of zinc plated and passivated steel. Rivets are of stainless steel, which burnishes and work-hardens with use, the rivets of the larger clamps rotating in hardened bushes or directly in the close-toleranced holes of hardened parts.

**Vertical Clamp Dimensions**

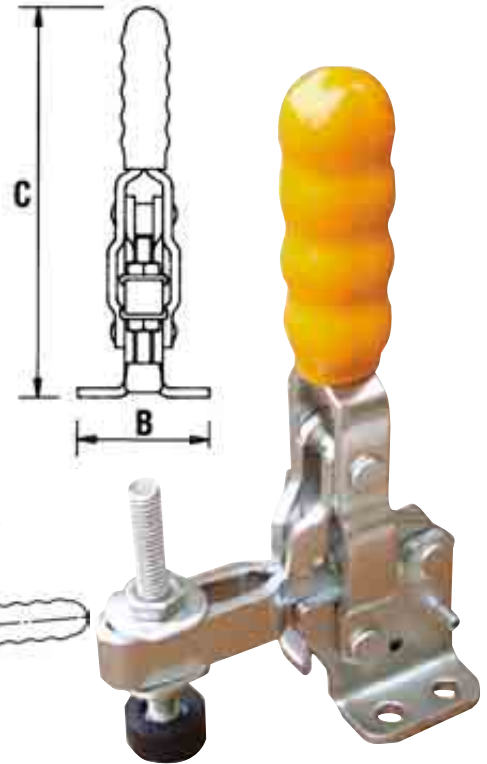

**EXTENDED RANGE**

**Flanged Clamp Dimensions:**

| Product Number | C (mm) | D (mm) | F (mm) | E (mm) | B (mm) |
|----------------|--------|--------|--------|--------|--------|
| V150/1C        | 135    | 26     | 28     | 27     | 12     |
| V450/1C        | 246    | 74     | 57     | 53     | 20     |
| V70/2BT        | 35     | 30.1   | 12.7   | 26.2   | 25.4   |
| V75/2B         | 98     | 31     | 16     | 26     | 34     |
| V100/2B        | 103    | 39     | 22     | 28     | 34     |
| V100/2C        | 103    | 37     | 22     | 28     | 34     |
| V100/3B        | 122    | 31     | 44     | 26     | 28     |
| V100/3C        | 122    | 24.5   | 44     | 36     | 28     |
| V150/2B        | 125    | 43     | 23     | 27     | 38     |
| V200/2B        | 135    | 44     | 29     | 35     | 42     |
| V250/2B        | 175    | 74     | 32     | 35     | 45     |
| V250/2BSS      | 175    | 74     | 32     | 35     | 45     |
| V250/2C        | 175    | 45     | 32     | 35     | 45     |
| V300/2B        | 186    | 100    | 42     | 43     | 52     |
| V350/2B        | 220    | 95     | 43     | 50     | 64     |
| V450/2B        | 228    | 122    | 51     | 53     | 64     |
| V550/2B        | 312    | 154    | 82     | 76     | 95     |

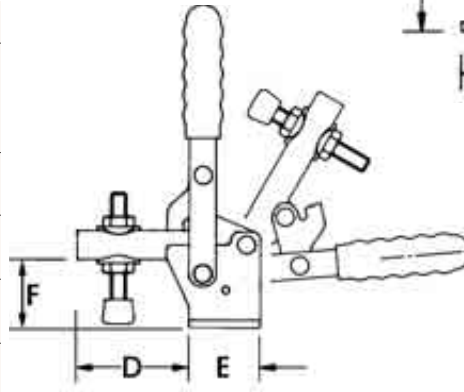

| Product Number | Holding Capacity | Movement Handle | Bar  | Base Type      | Supplied With  | Weight each | Order Code BRA-410 | Offer Price/1 |
|----------------|------------------|-----------------|------|----------------|--|-------------|--------------------|---------------|
| V150/1C        | 150daN           | 110°            | 185° | Straight Fixed | Set Screws and Nuts, Neoprene Cover                  | 0.15kg      | -1453D             | £13.80        |
| V450/1C        | 450daN           | 110°            | 180° |                | Set Screws and Nuts                                  | 1.30kg      | -1470X             | £36.73        |
| V70/2BT        | 70daN            | 92°             | 175° | Flanged        | Flat Cushion Spindle and Flanged Washers             | 0.10kg      | -1449A             | £13.99        |
| V75/2B         | 75daN            | 100°            | 160° |                | Tipped Spindle and Flanged Washers                   | 0.05kg      | -1451B             | £12.03        |
| V100/2B        | 100daN           | 105°            | 185° | Flanged        | Tipped Spindle and Flanged Washers                   | 0.10kg      | -1502C             | £13.85        |
| V100/2C        | 100daN           | 105°            | 185° |                | Set Screws and Nuts, Neoprene Cover                  | 0.15kg      | -1503D             | £13.85        |
| V150/2B        | 150daN           | 110°            | 185° | Flanged        | Tipped Spindle and Flanged Washers                   | 0.15kg      | -1454E             | £13.80        |
| V200/2B        | 200daN           | 95°             | 175° |                | Hex-Head Spindle and Flanged Washers                 | 0.20kg      | -1508J             | £17.12        |
| V200/2C        | 200daN           | 95°             | 175° | Flanged        | Set Screw, Nuts and Flanged Washers                  | 0.20kg      | -1509K             | £17.12        |
| V250/2B        | 250daN           | 100°            | 160° |                | Hex-Head Spindle and Flanged Washers                 | 0.38kg      | -1460L             | £16.52        |
| V250/2BSS      | 250daN           | 100°            | 160° | Flanged        | Set Screws and Nuts, Flanged Washers                 | 0.38kg      | -1460W             | £36.20        |
| V250/2C        | 250daN           | 100°            | 160° |                | MB0860 Set Screws and Nuts                           | 0.38kg      | -1461M             | £16.52        |
| V300/2B        | 300daN           | 90°             | 160° | Flanged        | Hex-Head Spindle and Flanged Washers                 | 0.48kg      | -1516S             | £22.89        |
| V300/2C        | 300daN           | 90°             | 160° |                | Set Screws and Nuts                                  | 0.48kg      | -1517T             | £22.89        |
| V350/2B        | 350daN           | 110°            | 180° | Flanged        | Hex-Head Spindle and Flanged Washers                 | 0.80kg      | -1466S             | £23.16        |
| V450/2B        | 450daN           | 110°            | 180° |                | Hex-Head Spindle and Flanged Washers                 | 1.35kg      | -1472Z             | £36.73        |
| V550/2B        | 550daN           | 110°            | 180° | Flanged        | Hex-Head Spindle and Flanged Washers                 | 2.40kg      | -1478F             | £43.88        |
| V100/3B        | 100daN           | 100°            | 190° |                | Set Screws and Nuts, Neoprene Cover, Flanged Washers | 0.25kg      | -1504E             | £13.85        |
| V100/3C        | 100daN           | 100°            | 190° | Front Mounting | Set Screws and Nuts, Neoprene Cover                  | 0.25kg      | -1505F             | £13.85        |
| V200/3B        | 200daN           | 95°             | 175° |                | Set Screw, Nuts and Flanged Washers                  | 0.25kg      | -1511L             | £17.12        |
| V300/3B        | 300daN           | 90°             | 160° |                | Set Screw, Nuts and Flanged Washers                  | 0.50kg      | -1519W             | £22.89        |

**Push-Pull Clamp**

**Features:** Comfortable, cushioned PVC orange handle grips. With flanged base and fixed position spindle.

**Specification:** The main components are of zinc plated and passivated steel. Rivets are of stainless steel, which burnishes and work-hardens with use.

All clamps are supplied with mounting nut and lock nut.

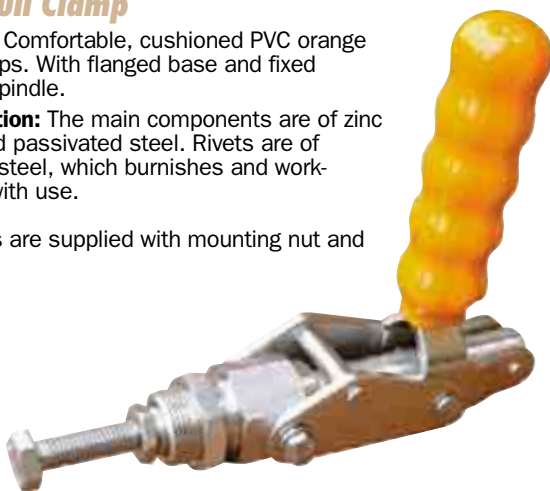

| Product Number | Holding Capacity | Movement Handle | Base    | Weight each | Order Code BRA-410 | Offer Price/1 |
|----------------|------------------|-----------------|---------|-------------|--------------------|---------------|
| P50            | 50daN            | 190°            | Flanged | 0.05kg      | -1200A             | £11.74        |
| P100           | 100daN           | 190°            |         | 0.15kg      | -1200M             | £27.31        |
| P550           | 550daN           | 185°            | Flanged | 0.45kg      | -1203D             | £47.40        |
| P200           | 200daN           | 190°            |         | 0.35kg      | -1200V             | £35.02        |
| P250           | 250daN           | 190°            |         | 0.30kg      | -1201B             | £24.43        |
| P450           | 450daN           | 185°            |         | 0.75kg      | -1202C             | £33.26        |
| P750           | 450daN           | 185°            |         | 1.00kg      | -1206T             | £63.77        |

**Heavy Duty Vertical Industrial Clamp**

**Features:** The heavy duty vertical series are designed to be adaptable and durable, and to withstand abuse in heavy duty applications.

**Specification:** The main components are of steel, the forked lower handles being precision alloy steel castings, and all axles of hardened steel running in either hardened bushes or directly in the close-toleranced holes of hardened steel. The clamps are finished chemi-black.

Supplied with hex head spindle and flanged washers.



**EXTENDED RANGE**

| Product Number | Holding Capacity | Movement Handle | Base Type | Weight each | Order Code BRA-410 | Offer Price/1 |
|----------------|------------------|-----------------|-----------|-------------|--------------------|---------------|
| VA300/2B       | 300daN           | 88°             | Flanged   | 0.25kg      | -1552L             | £53.09        |
| VA700/2C       | 700daN           | 120°            | Flanged   | 1.25kg      | -1555J             | £74.03        |

Workshop Equipment

**BRAUER®** *Horizontal Industrial Clamp*

**Features:** Comfortable, cushioned PVC orange handle grips.

**Specification:** The main components are of zinc plated and passivated steel. Rivets are of stainless steel, which burnishes and work-hardens with use, the rivets of the larger clamps rotating in hardened bushes or directly in the close-toleranced holes of hardened parts.

Model H700 features a heavy duty cast steel base with centre hole for optional 'Tee' bolt mounting.



**Horizontal Clamp Dimensions**

| Product Number | A (mm) | C (mm) | D (mm) | F (mm) | E (mm) | B (mm) |
|----------------|--------|--------|--------|--------|--------|--------|
| H350/1B        | 274    | 108    | 108    | 54     | 59     | 16     |
| H50/2B         | 70     | 22     | 26     | 11.5   | 24     | 24     |
| H75/2B         | 116    | 36     | 37     | 19     | 25     | 27     |
| H1001C         | 110    | 38     | 27     | 26     | 26     | 37     |
| H1002C         | 110    | 38     | 22     | 26     | 26     | 37     |
| H100/2B        | 110    | 32     | 38     | 22     | 26     | 34     |
| H150/2B        | 170    | 53     | 61     | 25     | 38     | 40     |
| H150/2C        | 155    | 53     | 38     | 25     | 38     | 40     |
| H200/2B        | 140    | 40     | 45     | 27     | 40     | 40     |
| H250/2B        | 224    | 67     | 79     | 34     | 42     | 46     |
| H350/2B        | 274    | 91     | 108    | 45     | 59     | 59     |
| H450/2B        | 305    | 110    | 128    | 59     | 66     | 67     |

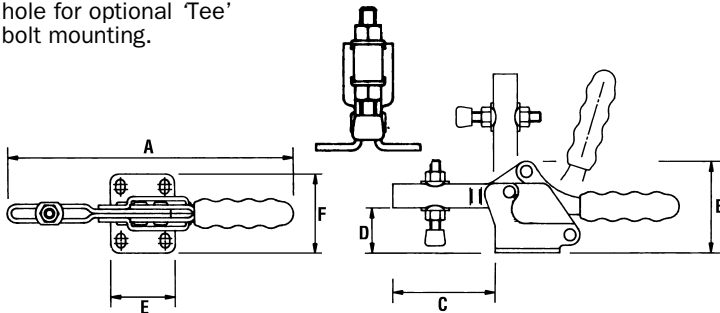

| Product Number | Holding Capacity | Movement Handle | Bar | Base Type | Supplied With                        | Weight each | Order Code BRA-410 | Offer Price/1 |
|----------------|------------------|-----------------|-----|-----------|--------------------------------------|-------------|--------------------|---------------|
| H350/1B        | 350daN           |                 |     | Straight  | Setscrews, Nuts and Washers          | 0.90kg      | -1129K             | £27.73        |
| H50/2B         | 50daN            | 65°             | 85° |           | Tipped Spindle and Flanged Washers   | 0.04kg      | -1100B             | £9.89         |
| H75/2B         | 75daN            | 75°             | 90° |           | Tipped Spindle and Flanged Washers   | 0.10kg      | -1121B             | £13.26        |
| H1001C         | 100daN           | 90°             | 90° | Straight  | Spindle, Nuts and Flanged Washers    | 0.85kg      | -1102R             | £15.14        |
| H1002C         | 100daN           | 90°             | 90° |           | Spindle, Nuts and Flanged Washers    | 0.85kg      | -1102Y             | £15.14        |
| H100/2B        | 150daN           | 90°             | 90° |           | Spindle & Nuts. Neoprene Cover       | 0.85kg      | -1103D             | £13.85        |
| H150/2B        | 150daN           | 80°             | 90° |           | Tipped Spindle and Flanged Washers   | 0.25kg      | -1124E             | £16.93        |
| H150/2C        | 150daN           | 80°             | 90° | Flanged   | Spindle, Nuts and Flanged Washers    | 0.25kg      | -1124Q             | £16.93        |
| H200/2B        | 200daN           | 90°             | 90° |           | Tipped Spindle and Flanged Washers   | 0.17kg      | -1108J             | £17.70        |
| H250/2B        | 250daN           | 80°             | 95° |           | Hex-Head Spindle and Flanged Washers | 0.50kg      | -1127H             | £21.30        |
| H350/2B        | 350daN           | 75°             | 90° |           | Hex-Head Spindle and Flanged Washers | 0.90kg      | -1130L             | £27.73        |
| H450/2B        | 450daN           | 75°             | 90° |           | Hex-Head Spindle and Flanged Washers | 1.60kg      | -1134P             | £40.78        |

**Hook (Latch) Type Industrial Clamp**

**Features:** The action of Hook clamps in pulling two parts together makes them suitable for applications such as closing and holding closed doors, lids, moulds, etc. A benefit of hook clamps is that while the clamp and the pin, or latch bracket it engages, must be in alignment when viewed from the top, there is no such requirement when viewed from the side - the clamp will lock securely over centre regardless of the angle of the hook. The hook may be engaged either directly to a bolt or pin on one of the parts to be pulled together, or to the latch bracket provided. All hook clamps are fitted with a comfortable, cushioned orange handle grip.

**Specification:** Components are of zinc plated and passivated steel, the hooks being high tensile alloy steel.

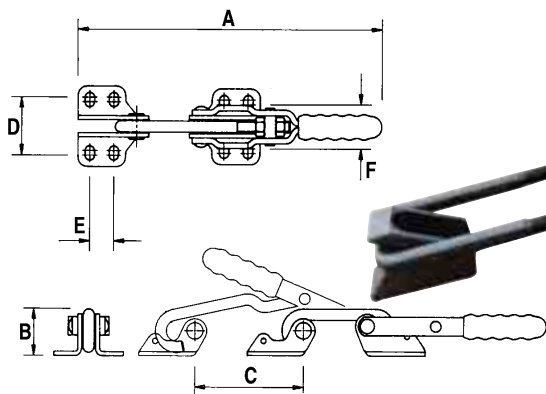

**Hook (Latch) Clamp Dimensions**

| Product Number | A (mm) | B (mm) | C (mm) | D (mm) | E (mm) | F (mm) |
|----------------|--------|--------|--------|--------|--------|--------|
| LH200          | 156    | 26     | 70     | 26     | 13     | 26     |
| LH400          | 248    | 37     | 90     | 35     | 19     | 36     |
| LH700          | 310    | 78     | 49     | 51     | 12     | 84     |

| Product Number | Holding Capacity | Movement Handle | Base Type | Supplied With             | Weight each | Order Code BRA-410 | Offer Price/1 |
|----------------|------------------|-----------------|-----------|---------------------------|-------------|--------------------|---------------|
| LH200          | 200daN           | 155°            | Flanged   | J-Style Latch and Bracket | 0.10kg      | -1150A             | £20.27        |
| LH400          | 400daN           | 155°            |           | J-Style Latch and Bracket | 0.35kg      | -1153D             | £21.75        |
| LH700          | 700daN           | 155°            |           | J-Style Latch and Bracket | 1.00kg      | -1157H             | £36.07        |

**Pull-Back Clamp (Toggle G-Clamp)**

**Features:** Comfortable, cushioned PVC orange handle grips. With flanged base and fixed position spindle.

**Specification:** The main components are of zinc plated and passivated steel. Rivets are of stainless steel, which burnishes and work-hardens with use.

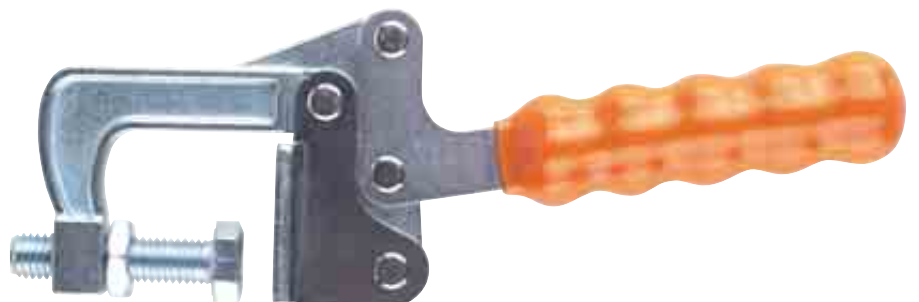

| Product Number | Holding Capacity | Movement Handle | Bar | Jaw Opening | Supplied With                          | Weight each | Order Code BRA-410 | Offer Price/1 |
|----------------|------------------|-----------------|-----|-------------|--|-------------|--------------------|---------------|
| TC79           | 360daN           | 50°             | 90° | 32mm        | M12 x 50 Hex-Head Spindle and nut lock | 0.50kg      | -1411M             | £31.73        |

**CONTRACT PRICES AVAILABLE FOR VOLUME PURCHASES**

**GROUP 445 VICES**

**KENNEDY PROFESSIONAL**

**Steel Bench Vices**

These premium quality bench vices are as good as you get, made from solid steel with replaceable jaws, integral pipe jaws and anvil for versatility. Available in 100mm (4") and 150mm (6").



**NEW**



| Model Number | Jaw Width x Opening (mm) | Weight each | Order Code    | List Price/1 | Offer Price/1  |
|--------------|--------------------------|-------------|---------------|--------------|----------------|
| VBS100       | 100 x 90                 |             | <b>-0500K</b> | £77.99       | <b>£51.47</b>  |
| VBS150       | 150 x 220                |             | <b>-0540K</b> | £189.99      | <b>£125.39</b> |

**IRWIN Record Mechanic's Vice**

Close grained cast grey iron body and sliding jaw which are machined on all friction surfaces for a smooth action. Fitted with steel handle and main screw.



**See Group 588**

| Model Number | Jaw (mm) Width x Opening | Weight each | Order Code    | List Price/1 | Offer Price/1  |
|--------------|--------------------------|-------------|---------------|--------------|----------------|
| T1           | 75 x 95                  | 6.8kg       | <b>-8210D</b> | £47.64       | <b>£33.35</b>  |
| T3           | 100 x 120                | 18.6kg      | <b>-8232K</b> | £92.66       | <b>£64.86</b>  |
| T4           | 115 x 124                | 23.6kg      | <b>-8240N</b> | £162.58      | <b>£113.81</b> |
| T5           | 125 x 165                | 28.8kg      | <b>-8248P</b> | £188.31      | <b>£131.82</b> |
| T6           | 150 x 205                | 39.5kg      | <b>-8259R</b> | £280.15      | <b>£196.10</b> |
| T6VS         | 150 x 205                | 39.5kg      | <b>-8262V</b> | £345.15      | <b>£241.60</b> |
| T8           | 205 x 235                | 45.8kg      | <b>-8273Q</b> | £500.07      | <b>£350.05</b> |
| T5VS         | 125 x 156                | 8.8kg       | <b>-8250Q</b> | £228.00      | <b>£159.60</b> |

Workshop Equipment

**SENATOR QUALITY TOOLING**

**Engineer's Vice**

Manufactured from the highest quality castings with precision cut screw mechanisms and precision machined jaws. Suitable for workshop, automotive and engineering use.



**For Workbenches**



**See Group 405**



Do Not Strike With A Hammer

| Opening (mm) | Jaw Width (mm) | Weight each | Order Code    | List Price/1 | Offer Price/1 |
|--------------|----------------|-------------|---------------|--------------|---------------|
| 100 (4")     | 75 (3")        | 9.2kg       | <b>-1030K</b> | £31.01       | <b>£20.47</b> |
| 140 (5½")    | 100 (4")       | 9.5kg       | <b>-1040K</b> | £45.58       | <b>£30.08</b> |
| 170 (6½")    | 125 (5")       | 18.0kg      | <b>-1050K</b> | £61.54       | <b>£40.62</b> |
| 190 (7½")    | 150 (6")       | 27.0kg      | <b>-1060K</b> | £84.38       | <b>£55.69</b> |

**Replacement Jaws (Pairs)**

| Engineers Vice Size     | Weight each | Order Code    | Offer Price/1 |
|-------------------------|-------------|---------------|---------------|
| To suit 75mm jaw width  | 1.4kg       | <b>-1030K</b> | <b>£10.36</b> |
| To suit 100mm jaw width | 1.8kg       | <b>-1040K</b> | <b>£15.01</b> |
| To suit 125mm jaw width | 2.0kg       | <b>-1050K</b> | <b>£26.94</b> |
| To suit 150mm jaw width | 2.3kg       | <b>-1060K</b> | <b>£41.28</b> |

**Woodcraft Vice**

A light duty low cost equivalent to the woodworking vice. Cast grey iron body and front plate, with steel handle main screw and slide rods. The TV150 vice is a portable version, which can be clamped to any convenient surface.



**V175**

| Model Number | Jaw (mm) Width x Opening | Weight each | Order Code    | List Price/1 | Offer Price/1 |
|--------------|--------------------------|-------------|---------------|--------------|---------------|
| TV150        | 15 x 115                 | 2.8kg       | <b>-8396G</b> | £25.98       | <b>£18.19</b> |
| TV175        | 175 x 165                | 5.3kg       | <b>-8397H</b> | £28.85       | <b>£20.20</b> |

**Woodworking Vice**

Cast grey iron body and front plate, fitted with two solid steel guide rods for smooth parallel action.

Designed for bench mounting, available with a quick release mechanism or just as a plain screw type. Fitted with a front dog, which when used in conjunction with a bench stop allows oversized work to be held securely.

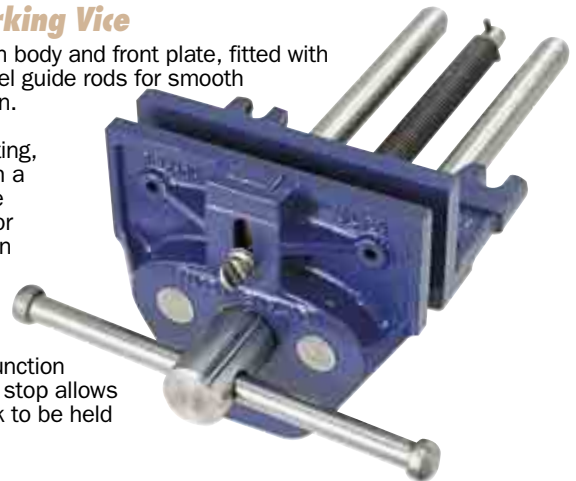

| Model Number                    | Jaw (mm) Width x Opening | Weight each | Order Code    | List Price/1 | Offer Price/1  |
|---------------------------------|--------------------------|-------------|---------------|--------------|----------------|
| <b>Quick Release Screw Type</b> |                          |             |               |              |                |
| T52ED                           | 175 x 205                | 9.1kg       | <b>-8309Y</b> | £127.59      | <b>£89.31</b>  |
| T53ED                           | 250 x 380                | 19kg        | <b>-8312D</b> | £189.03      | <b>£132.32</b> |
| <b>Plain Screw Type</b>         |                          |             |               |              |                |
| T52½PD                          | 230 x 330                | 16.3kg      | <b>-8309C</b> | £80.50       | <b>£56.35</b>  |
| T52PD                           | 175 x 205                | 9.1kg       | <b>-8311T</b> | £60.75       | <b>£42.52</b>  |



**IRWIN** *Engineer's Vice - Quick Release*

Heavy-duty vices which are engineered with an anvil which allows for shaping beating and more robust work. SG ductile iron body and sliding jaw which are machined on all friction surfaces for a smooth action. Fitted with steel handle and main screw.



| Model Number | Jaw (mm) Width x Opening | Weight each | Order Code REC-565 | List Price/1 | Offer Price/1  |
|--------------|--------------------------|-------------|--------------------|--------------|----------------|
| T84 - 34     | 115 x 145                | 17.2kg      | -8326K             | £495.97      | <b>£347.18</b> |
| T36          | 150 x 190                | 28.6kg      | -8298P             | £854.14      | <b>£597.90</b> |
| T112         | 150 x 185                | 32.7kg      | -8356S             | £797.93      | <b>£558.55</b> |
| T114         | 205 x 235                | 39.0kg      | -8362W             | £1100.68     | <b>£770.48</b> |

**Table Vice**

Can be fitted to any convenient work surface. Solid cast grey iron body with steel guide rods and main screw.

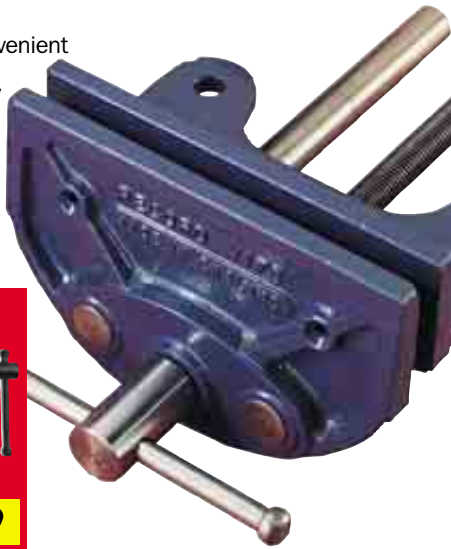

**For G-Clamps**

**See Group 539**

| Model Number | Jaw (mm) Width x Opening | Weight each | Order Code REC-565 | List Price/1 | Offer Price/1 |
|--------------|--------------------------|-------------|--------------------|--------------|---------------|
| V75          | 75 x 50                  | 2.10kg      | -8395B             | £22.13       | <b>£15.49</b> |

**Fitter's Vice - Quick Release**

Fitted with a quick release mechanism to allow rapid movement of the jaw which saves time on repetitive work. Close grained cast grey iron body and sliding jaw which are machined on all friction surfaces for a smooth action. Fitted with steel handle and main screw. Guaranteed unbreakable.



| Model Number | Jaw (mm) Width x Opening | Weight each | Order Code REC-565 | List Price/1 | Offer Price/1  |
|--------------|--------------------------|-------------|--------------------|--------------|----------------|
| T23          | 110 x 165                | 27.9kg      | -8276A             | £368.38      | <b>£257.87</b> |
| T25          | 150 x 210                | 40.9kg      | -8282A             | £488.37      | <b>£341.86</b> |

**SENATOR** *Workshop Vice*

American pattern bench mounting, steel vice with anvil suitable for workshop, garage and machine-shop use. Fixed base directly mounts onto work bench. Cast iron body with steel jaws and a cross drilled threaded handle with adjustable T-bar for extra leverage.



| Opening (mm)            | Jaw Width (mm) | Weight each | Order Code SEN-445 | List Price/1 | Offer Price/1 |
|-------------------------|----------------|-------------|--------------------|--------------|---------------|
| 145 (5 <sup>3/4</sup> " | 100 (4")       | 13.5kg      | -2040K             | £60.78       | <b>£40.11</b> |
| 200 (8")                | 150 (6")       | 14.0kg      | -2060K             | £104.79      | <b>£69.16</b> |

**Portable Bench Vice**

Lightweight and portable with a swivel base and light duty anvil. Ideal for model makers, DIY and light industrial use. Can be fitted to any convenient work surface. Solid cast grey iron body with steel guide rods and main screw.



| Opening (mm)           | Jaw Width | Weight each | Order Code SEN-445 | List Price/1 | Offer Price/1 |
|------------------------|-----------|-------------|--------------------|--------------|---------------|
| 70 (2 <sup>3/4</sup> " | 60        | 2.8kg       | -0600K             | £23.04       | <b>£15.21</b> |

**125mm (5") Universal Vice**

Can be bench mounted either vertically or horizontally. Unique design permits the vice to rotate a full 360° then self-lock when jaws are tightened. **Jaw height: 54mm (2<sup>1/8</sup>"**).

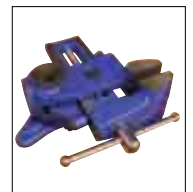

| Opening (mm) | Jaw Width              | Jaw Height             | Weight each | Order Code SEN-445 | List Price/1 | Offer Price/1 |
|--------------|------------------------|------------------------|-------------|--------------------|--------------|---------------|
| 125 (5")     | 90 (3 <sup>1/2</sup> " | 54 (2 <sup>1/8</sup> " | 8.2kg       | -4050K             | £56.16       | <b>£37.07</b> |

**CONTRACT PRICES AVAILABLE FOR VOLUME PURCHASES**

All Prices Exclude V.A.T. © 2013

Workshop Equipment

**GROUP 445 VICES**

**SENATOR** Drill Press Vice  
QUALITY TOOLING Vice

Suitable for use on pillar/bench drills to steady the workpiece in all light duty drilling applications for the garage or small workshop. Cast construction with machined slots which are spaced to fit all popular drill stand bases. Cross drilled handle with sliding T-bar for extra leverage.



| Jaw Width | Maximum Opening | Jaw Height | O/all Dimension Length x Height | Weight each | Order Code <b>SEN-445</b> | List Price/1 | Offer Price/1 |
|-----------|-----------------|------------|---------------------------------|-------------|---------------------------|--------------|---------------|
| 75mm      | 55              | 23         | 200 x 45                        | 1.90kg      | <b>-0750K</b>             | £18.22       | <b>£12.03</b> |
| 100mm     | 95              | 25         | 250 x 55                        | 3.25kg      | <b>-1000K</b>             | £20.21       | <b>£13.34</b> |

**ATLAS** Machine Vices  
WORKHOLDERS Vices

**Machine Vices without Swivel Base**  
Manufactured in accordance with high quality criteria. Designed for general purpose milling, planing and drilling applications.

**Machine Vices with Swivel Base Type**  
Also available complete with a swivel base designed for milling, planing and drilling applications. Graduated to 1°.



**Swivel Base Type**

Jaws are fully ground in pairs

| Jaw Width                  | Max. Opening | Jaw Height | O/all Dimension L x W x H | Weight each | Order Code <b>ATL-445</b> | List Price/1 | Offer Price/1  |
|----------------------------|--------------|------------|---------------------------|-------------|---------------------------|--------------|----------------|
| <b>Without Swivel Base</b> |              |            |                           |             |                           |              |                |
| 100mm                      | 80           | 35         | 245 x 115 x 89            | 8kg         | <b>-0100K</b>             | £120.00      | <b>£57.60</b>  |
| 160mm                      | 125          | 51         | 411 x 187 x 120           | 34kg        | <b>-0150K</b>             | £208.00      | <b>£99.84</b>  |
| 200mm                      | 160          | 63         | 440 x 220 x 140           | 46kg        | <b>-0200K</b>             | £282.00      | <b>£135.36</b> |
| <b>With Swivel Base</b>    |              |            |                           |             |                           |              |                |
| 100mm                      | 80           | 35         | 195 x 145 x 110           | 17kg        | <b>-1100K</b>             | £152.00      | <b>£72.96</b>  |
| 160mm                      | 125          | 51         | 411 x 187 x 167           | 43kg        | <b>-1150K</b>             | £253.00      | <b>£121.44</b> |
| 200mm                      | 160          | 63         | 440 x 220 x 187           | 57kg        | <b>-1200K</b>             | £337.00      | <b>£161.76</b> |

**Spare Jaws to suit Atlas Machine Vices**

| Width | Order Code <b>ATL-445</b> | Offer Price/1 |
|-------|---------------------------|---------------|
| 100mm | <b>-1040K</b>             | <b>£5.19</b>  |
| 160mm | <b>-1060K</b>             | <b>£6.33</b>  |
| 200mm | <b>-1080K</b>             | <b>£6.60</b>  |

**Toolmaker's Vice - V-Groove Jaw**

Made from alloy steel, case hardened. With a quick release mechanism.

**Accuracy:**  
0.005mm.



| Jaw Dimension Width x Opening x Height | Overall Length | Weight each | Order Code <b>ATL-445</b> | List Price/1 | Offer Price/1 |
|--|----------------|-------------|---------------------------|--------------|---------------|
| 50 x 65 x 25mm                         | 135            | 3kg         | <b>-0310K</b>             | £154.00      | <b>£73.92</b> |

**Toolmaker's Vices**

Manufactured from high carbon steel, precision ground on all faces. Phosphor bronze bush, 90° vee on clamping jaws.

**Standard Precision Toolmaker's Vices**  
Squareness and parallelism to within 0.005mm.

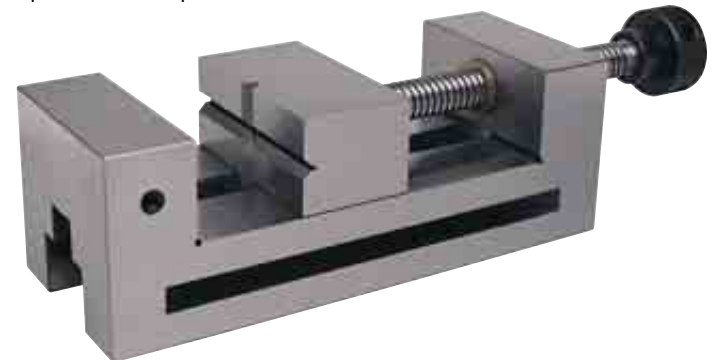

| Jaw Dimension Width x Opening x Height | Overall Length | Weight each | Order Code <b>ATL-445</b> | List Price/1 | Offer Price/1  |
|--|----------------|-------------|---------------------------|--------------|----------------|
| 63 x 85 x 32mm                         | 185            | 3.80kg      | <b>-2010K</b>             | £242.00      | <b>£116.16</b> |
| 100 x 125 x 45mm                       | 255            | 13.00kg     | <b>-2050K</b>             | £299.00      | <b>£143.52</b> |

Workshop Equipment

**INDEXA** Drill Press Vices  
Quick Grip

**Fixed Jaw**

Quick acting cam can be set instantly to hold work. Fixed jaw with V-block to handle flat or round pieces, vertically or horizontally. Jaw inserts are hardened and ground. The heavy base can be clamped down to a milling machine or drill press.



| Jaw Width | Jaw Height | Maximum Opening | Weight each | Order Code <b>IND-445</b> | List Price/1 | Offer Price/1  |
|-----------|------------|-----------------|-------------|---------------------------|--------------|----------------|
| 80mm      | 30mm       | 80mm            | 5.2kg       | <b>-0170K</b>             | £140.03      | <b>£105.02</b> |
| 100mm     | 35mm       | 100mm           | 8.9kg       | <b>-0180K</b>             | £195.87      | <b>£146.90</b> |

**Sliding Jaw**

Recessed, replaceable jaws. Quick-acting cam gives instant settings by moving sliding steel bar attached to inside jaw. With cut-out base for clear through drilling. Hardened and ground lever arm locking mechanism. Heavy base can be clamped down to a milling machine or drill press. Adjustable clamping pressure.



| Jaw Width | Max. Opening | Overall Length | Base Width | Weight each | Order Code <b>IND-445</b> | List Price/1 | Offer Price/1  |
|-----------|--------------|----------------|------------|-------------|---------------------------|--------------|----------------|
| 80mm      | 80mm         | 222mm          | 120mm      | 4.0kg       | <b>-0110K</b>             | £146.71      | <b>£110.03</b> |
| 100mm     | 125mm        | 293mm          | 160mm      | 7.0kg       | <b>-0120K</b>             | £171.97      | <b>£128.98</b> |
| 125mm     | 150mm        | 327mm          | 185mm      | 10.0kg      | <b>-0130K</b>             | £229.84      | <b>£172.38</b> |
| 160mm     | 160mm        | 380mm          | 224mm      | 15.5        | <b>-0140K</b>             | £283.63      | <b>£212.72</b> |



## INDEXA Drill Press Vices

Available in four different jaw widths. For drilling, light milling, vertical and horizontal work. One grooved and one plain replaceable jaw for square and hexagonal shapes across flats or corners, thin strips and discs. Jaws and lead screw are hardened and ground.



| Jaw Width | Jaw Opening | Order Code<br><b>IND-445</b> | List Price/1 | Offer Price/1 |
|-----------|-------------|------------------------------|--------------|---------------|
| 85mm      | 70mm        | <b>-0010K</b>                | £40.36       | <b>£30.27</b> |
| 100mm     | 85mm        | <b>-0020K</b>                | £43.20       | <b>£32.40</b> |
| 120mm     | 120mm       | <b>-0030K</b>                | £66.45       | <b>£49.84</b> |
| 150mm     | 150mm       | <b>-0040K</b>                | £78.51       | <b>£58.88</b> |

## Precision Toolmaker's Vices

Squareness and parallelism to within **0.003mm**. Designed for precision grinding and many other tool room applications.



| Jaw Dimension<br>Width x Opening x Height | Overall Length | Weight each | Order Code<br><b>IND-445</b> | List Price/1 | Offer Price/1  |
|---|----------------|-------------|------------------------------|--------------|----------------|
| 50 x 65 x 25mm                            | 150            | 3.00kg      | <b>-0400K</b>                | £324.30      | <b>£243.22</b> |
| 73 x 100 x 35mm                           | 205            | 5.00kg      | <b>-0430K</b>                | £349.60      | <b>£262.20</b> |
| 100 x 125 x 45mm                          | 255            | 13.00kg     | <b>-0450K</b>                | £401.35      | <b>£301.01</b> |

## Toolmaker's Vices - Plain Jaw

Manufactured from high quality alloy steel, case hardened to HRC 58 - 62. For wire cutting, machining, measurement and inspection. With a dowel pin quick release mechanism with linear scale for accurate alignment.

**Accuracy:** 0.003mm.

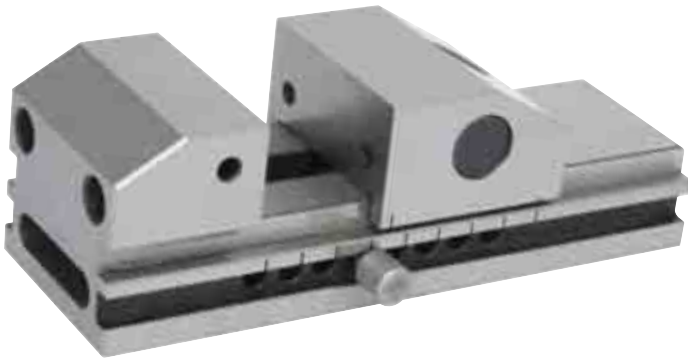

| Jaw Dimension<br>Width x Opening x Height | Overall Length | Weight each | Order Code<br><b>IND-445</b> | List Price/1 | Offer Price/1  |
|---|----------------|-------------|------------------------------|--------------|----------------|
| 60 x 80 x 28mm                            | 175mm          | 3.9kg       | <b>-0200K</b>                | £179.96      | <b>£134.97</b> |
| 75 x 100 x 40mm                           | 220mm          | 7.9kg       | <b>-0210K</b>                | £250.07      | <b>£187.55</b> |

## Toolmaker's Vice - V-Groove Jaw

Manufactured from high quality alloy steel, case hardened to HRC 58 - 62. With a rack quick release mechanism.

**Accuracy:** 0.003mm.

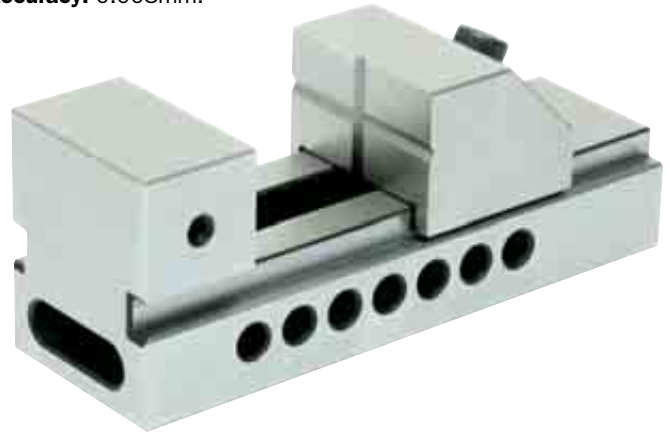

| Jaw Dimension<br>Width x Opening x Height | Overall Length | Weight each | Order Code<br><b>IND-445</b> | List Price/1 | Offer Price/1  |
|---|----------------|-------------|------------------------------|--------------|----------------|
| 50 x 78 x 30mm                            | 155mm          | 3.00kg      | <b>-0310K</b>                | £222.36      | <b>£166.77</b> |

## Modular Precision Machine Vices

Precision modular vices are designed to be used on standard and CNC machines for precision grinding and milling. The vice could be set up individually or work in multiples, on tables or palletised components depending on the machined material dimensions. Made from hardened high grade alloy steel.

**Parallelism:** 0.005mm.

**Perpendicular accuracy:** 0.005mm.

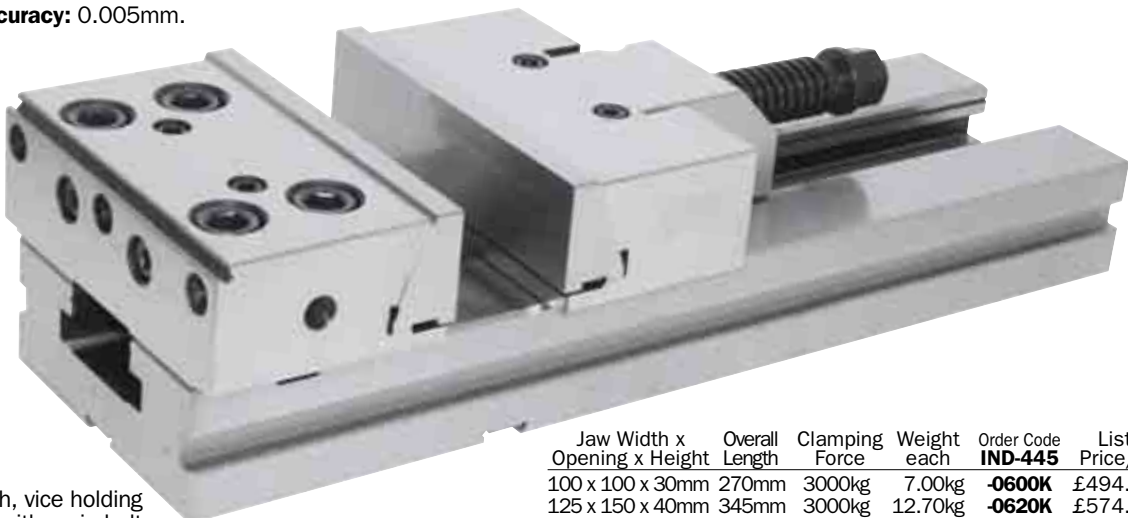

### Accessories:

L-wrench, T-wrench, vice holding clamp, work stop with main bolt, positioning key-nuts etc.

| Jaw Width x<br>Opening x Height | Overall Length | Clamping Force | Weight each | Order Code<br><b>IND-445</b> | List Price/1 | Offer Price/1  |
|---------------------------------|----------------|----------------|-------------|------------------------------|--------------|----------------|
| 100 x 100 x 30mm                | 270mm          | 3000kg         | 7.00kg      | <b>-0600K</b>                | £494.75      | <b>£371.06</b> |
| 125 x 150 x 40mm                | 345mm          | 3000kg         | 12.70kg     | <b>-0620K</b>                | £574.99      | <b>£431.24</b> |
| 150 x 200 x 50mm                | 420mm          | 5000kg         | 25.60kg     | <b>-0640K</b>                | £802.31      | <b>£601.73</b> |
| 150 x 300 x 50mm                | 520mm          | 5000kg         | 29.50kg     | <b>-0660K</b>                | £829.06      | <b>£621.79</b> |

**CONTRACT PRICES AVAILABLE FOR VOLUME PURCHASES**

All Prices Exclude V.A.T. © 2011

Made of alloy case steel. All working surfaces are hardened and precision ground.



**Toolposts Type T.00 - T.0**

Set-up for 2 Toolholders

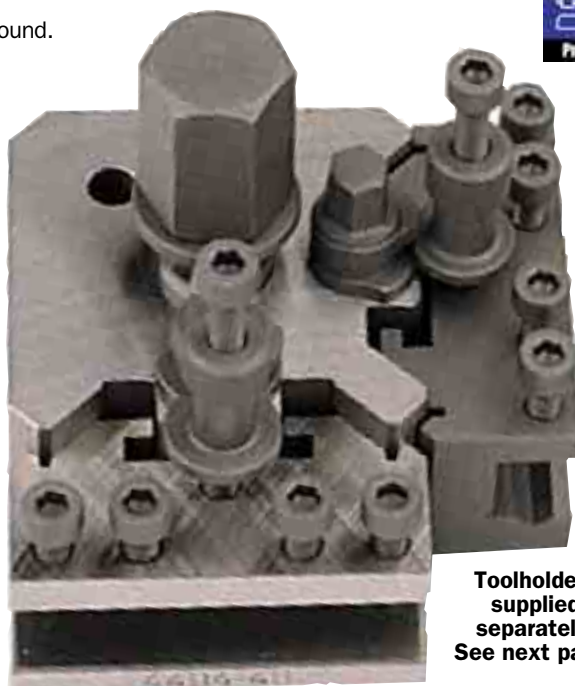
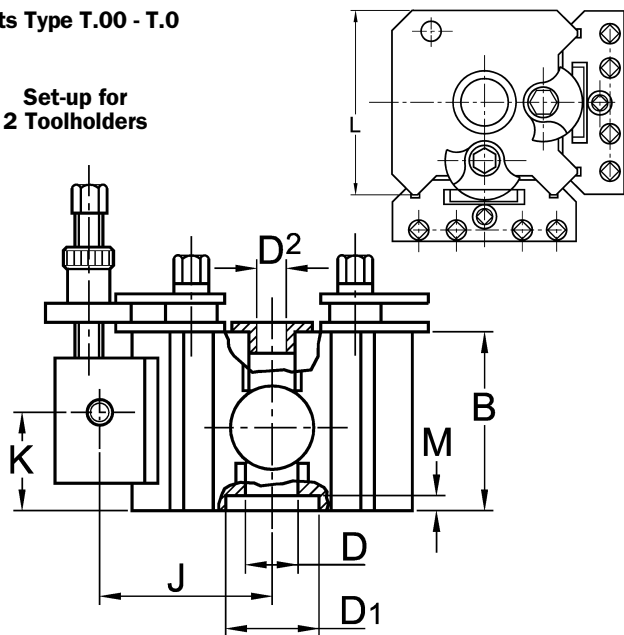

Toolholders supplied separately. See next page.

| Type  | No. of Toolholders | Lathe Capacity | B    | D <sub>1</sub> Dia. | M Depth | D    | E   | G  | F  | H <sub>1</sub> Max | H <sub>1</sub> Min. |
|-------|--------------------|----------------|------|---------------------|---------|------|-----|----|----|--------------------|---------------------|
| T.00M | 2                  | Up to 89mm     | 37.0 | -                   | -       | 11.2 | -   | 10 | 11 | 27                 | 17                  |
| T.00B | 2                  | Up to 89mm     | 42.0 | -                   | -       | 16.0 | -   | 10 | 11 | 32                 | 17                  |
| T.0   | 3                  | Up to 114mm    | 51.0 | 22.22               | 5.0     | 19.0 | 124 | 13 | 13 | 36.5               | 20.5                |

| Type  | Bar dia. d Max. | H Max. | H Min. | Taper | J    | K Max. | K Min. | L    | D <sub>2</sub> | Weight each | Order Code IND-445 | List Price/1 | Offer Price/1  |
|-------|-----------------|--------|--------|-------|------|--------|--------|------|----------------|-------------|--------------------|--------------|----------------|
| T.00M | 11.0            | 22.5   | 12.5   | -     | -    | -      | -      | 58.0 | -              | 0.90kg      | <b>-4800K</b>      | £123.91      | <b>£92.93</b>  |
| T.00B | 11.0            | 27.5   | 12.5   | -     | -    | -      | -      | 58.0 | -              | 1.10kg      | <b>-4810K</b>      | £133.82      | <b>£100.36</b> |
| T.0   | 16.0            | 32.0   | 16.0   | 1     | 52.5 | 28.5   | 16.0   | 73.0 | 16.0           | 2.00kg      | <b>-4820K</b>      | £151.35      | <b>£113.51</b> |

**Toolposts Type T.1 - T.3**

Set-up for 3 Toolholders

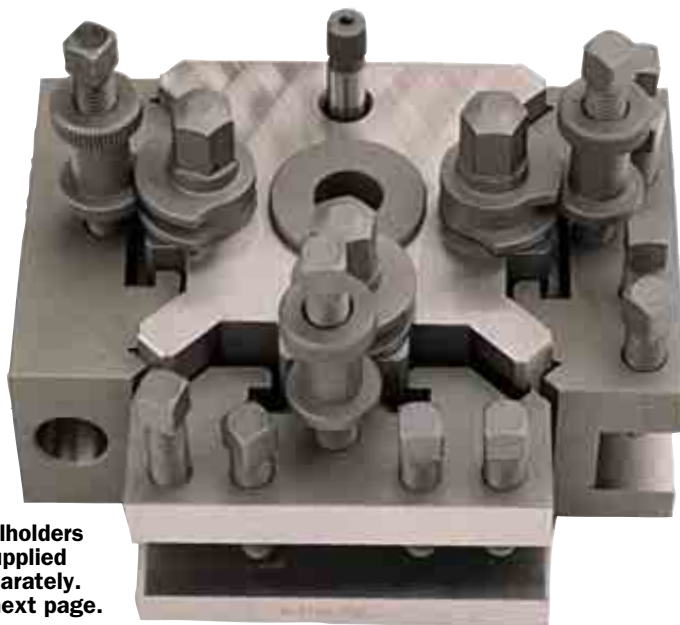
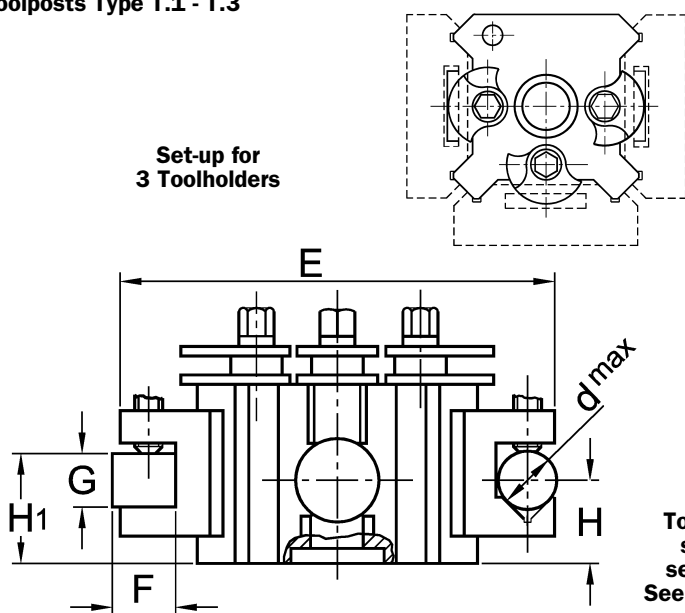

Toolholders supplied separately. See next page.

| Type | No. of Toolholders | Lathe Capacity | B    | D <sub>1</sub> Dia. | M Depth | D    | E   | G    | F    | H <sub>1</sub> Max | H <sub>1</sub> Min. |
|------|--------------------|----------------|------|---------------------|---------|------|-----|------|------|--------------------|---------------------|
| T.1  | 3                  | 114 to 127mm   | 63.5 | 31.75               | 6.5     | 19.0 | 124 | 19   | 13   | 46                 | 30                  |
| T.1X | 3                  | 114 to 127mm   | 73.0 | 31.75               | 6.5     | 19.0 | 124 | 19   | 13   | 57                 | 35                  |
| T.2  | 3                  | 127 to 203mm   | 71.5 | 44.45               | 8.0     | 25.5 | 159 | 19   | 19   | 54                 | 36.5                |
| T.2T | 3                  | 127 to 203mm   | 76.0 | 44.45               | 8.0     | 25.5 | 168 | 25.5 | 25.5 | 58.5               | 39.5                |
| T.3  | 3                  | 203 to 292mm   | 92.0 | 50.80               | 9.5     | 25.5 | 203 | 31.5 | 22.5 | 73                 | 51                  |

| Type | Bar dia. d Max. | H Max. | H Min. | Taper | J    | K Max. | K Min. | L     | D <sub>2</sub> | Weight each | Order Code IND-445 | List Price/1 | Offer Price/1  |
|------|-----------------|--------|--------|-------|------|--------|--------|-------|----------------|-------------|--------------------|--------------|----------------|
| T.1  | 16.0            | 44.5   | 25.5   | 1     | 52.5 | 41.0   | 22.0   | 73.0  | 16.0           | 2.30kg      | <b>-4830K</b>      | £171.16      | <b>£128.37</b> |
| T.1X | 16.0            | 54.0   | 32.0   | 1 & 2 | 52.5 | 51.0   | 28.5   | 73.0  | 16.0           | 2.60kg      | <b>-4840K</b>      | £188.34      | <b>£141.25</b> |
| T.2  | 19.0            | 46.0   | 24.0   | 2     | 65.0 | 47.5   | 27.0   | 98.5  | 16.0           | 4.60kg      | <b>-4850K</b>      | £222.04      | <b>£166.53</b> |
| T.2T | 19.0            | 50.0   | 24.0   | 2 & 3 | 70.0 | 47.5   | 27.0   | 106.5 | 16.0           | 5.80kg      | <b>-4860K</b>      | £242.86      | <b>£182.15</b> |
| T.3  | 25.5            | 51.0   | 28.5   | 3     | 85.5 | 58.5   | 36.5   | 125.5 | 22.0           | 10.8kg      | <b>-4870K</b>      | £310.56      | <b>£232.92</b> |



**INDEXA** Toolholders for Quick Change Toolposts

**Standard Type**

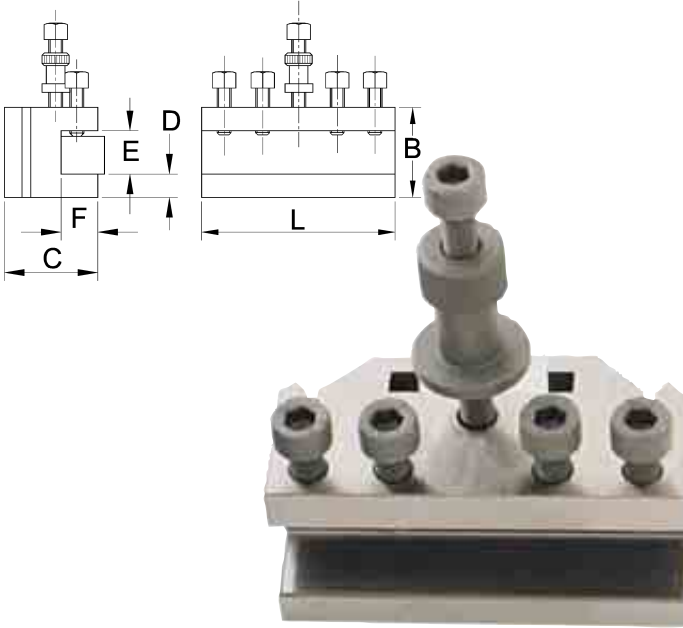

| Used On | L (mm) | B    | C    | D    | E    | F  | Order Code IND-445 | List Price/1 | Offer Price/1 |
|---------|--------|------|------|------|------|----|--------------------|--------------|---------------|
| T.00    | 58.0   | 27.0 | 28.0 | 7.0  | 13.0 | 11 | -5010K             | £29.76       | £22.32        |
| T.0     | 73.0   | 35.0 | 32.0 | 8.0  | 16.0 | 14 | -5020K             | £42.56       | £31.92        |
| T.1     | 73.0   | 44.5 | 32.0 | 11.0 | 22.0 | 14 | -5030K             | £57.95       | £43.46        |
| T.2     | 98.5   | 50.0 | 40.0 | 12.0 | 22.0 | 19 | -5040K             | £67.40       | £50.55        |
| T.2T    | 98.5   | 57.0 | 40.0 | 14.0 | 28.5 | 19 | -5050K             | £69.72       | £52.29        |
| T.3     | 124.0  | 70.0 | 48.5 | 17.5 | 35.0 | 23 | -5060K             | £85.52       | £64.14        |

**Vee Type**

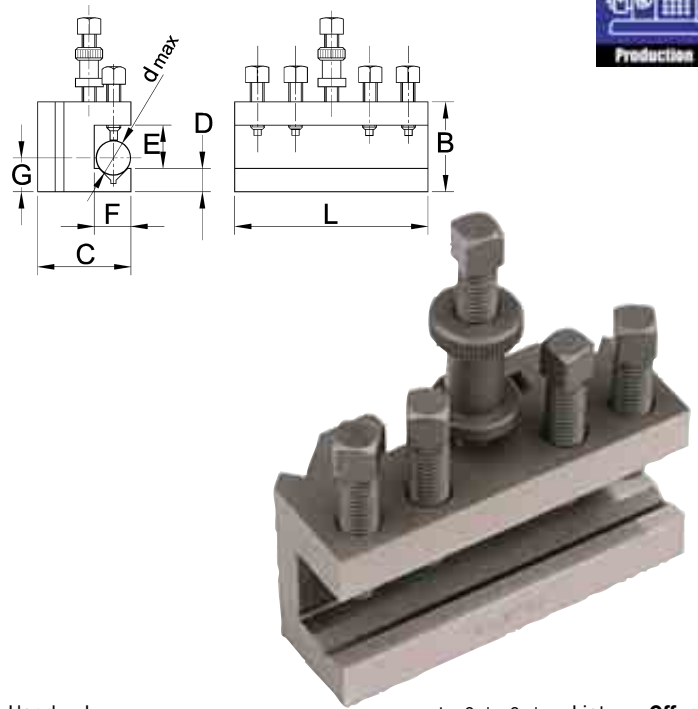

| Used On | L (mm) | B    | C    | D    | E    | F  | G    | d Max | Order Code IND-445 | List Price/1 | Offer Price/1 |
|---------|--------|------|------|------|------|----|------|-------|--------------------|--------------|---------------|
| T.00    | 58.0   | 27.0 | 28.0 | 8.0  | 13.0 | 11 | 13.5 | 11.0  | -5110K             | £33.89       | £25.42        |
| T.0     | 73.0   | 35.0 | 32.0 | 8.0  | 16.0 | 14 | 16.0 | 16.0  | -5120K             | £48.57       | £36.43        |
| T.1     | 73.0   | 44.5 | 32.0 | 11.0 | 22.0 | 14 | 24.0 | 16.0  | -5130K             | £63.00       | £47.25        |
| T.2     | 98.5   | 50.0 | 40.0 | 14.0 | 22.0 | 19 | 24.0 | 19.0  | -5140K             | £72.94       | £54.70        |
| T.2T    | 98.5   | 57.0 | 40.0 | 14.0 | 28.5 | 19 | 24.0 | 19.0  | -5150K             | £75.41       | £56.56        |
| T.3     | 124.0  | 70.0 | 48.5 | 17.5 | 35.0 | 23 | 28.5 | 25.5  | -5160K             | £90.88       | £68.16        |

**Parting Off Type**

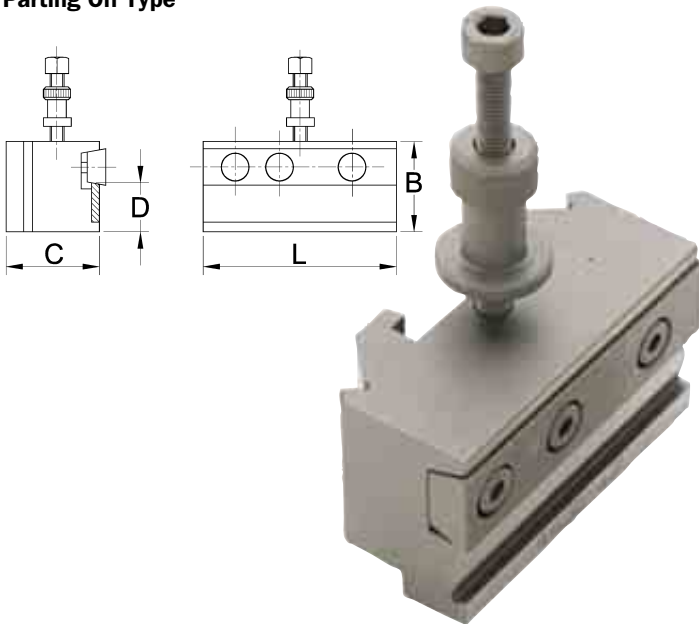

| Used On | L (mm) | B    | C    | D    | Order Code IND-445 | List Price/1 | Offer Price/1 |
|---------|--------|------|------|------|--------------------|--------------|---------------|
| T.0/T.1 | 73.0   | 47.5 | 32.0 | 27.0 | -5370K             | £70.36       | £52.77        |
| T.2     | 98.5   | 57.0 | 39.5 | 33.5 | -5380K             | £91.19       | £68.39        |
| T.3     | 124.0  | 70.0 | 48.5 | 33.5 | -5390K             | £114.99      | £86.24        |

**Morse Taper Type**

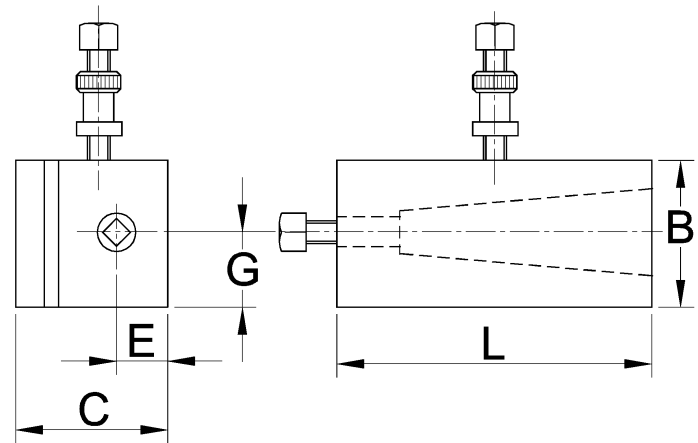

| Used On | L (mm) | B    | C    | E    | G  | Morse Taper | Order Code IND-445 | List Price/1 | Offer Price/1 |
|---------|--------|------|------|------|----|-------------|--------------------|--------------|---------------|
| T.0     | 73.0   | 36.0 | 31.5 | 9.5  | 16 | 1MT         | -5210K             | £63.44       | £47.58        |
| T.1     | 73.0   | 44.5 | 31.5 | 9.5  | 22 | 1MT         | -5220K             | £77.03       | £57.77        |
| T.1     | 95.0   | 44.5 | 41.5 | 16.5 | 22 | 2MT         | -5230K             | £77.03       | £57.77        |
| T.2     | 98.5   | 50.0 | 40.0 | 14.0 | 22 | 2MT         | -5240K             | £101.02      | £75.77        |

**Toolpost & Toolholder Combinations**

Ideal for all machine shop use.  
Refer above for dimensional information.

| Toolpost | Toolholders Included | Weight each | Order Code IND-445 | List Price/1 | Offer Price/1 |
|----------|----------------------|-------------|--------------------|--------------|---------------|
| T.0      | 2 Standard Type      | 3.10kg      | -5700K             | £227.90      | £170.93       |



**CONTRACT PRICES AVAILABLE FOR VOLUME PURCHASES**

**INDEXA**

*Industrial  
Lathe Carriers*

Available with straight or bent tail. Manufactured from high grade, malleable cast iron with high tensile strength. Smooth action square head clamping screw.



**Straight**



| Type     | Capacity | Weight each | Order Code<br><b>IND-445</b> | List Price/1 | Offer Price/1 |
|----------|----------|-------------|------------------------------|--------------|---------------|
| Straight | 12.5mm   | 0.10kg      | <b>-9000K</b>                | £10.67       | <b>£7.68</b>  |
|          | 19.0mm   | 0.15kg      | <b>-9010K</b>                | £12.09       | <b>£8.70</b>  |
|          | 25.0mm   | 0.30kg      | <b>-9020K</b>                | £14.93       | <b>£10.75</b> |
|          | 38.0mm   | 0.70kg      | <b>-9040K</b>                | £21.32       | <b>£15.35</b> |
|          | 50.0mm   | 1.50kg      | <b>-9060K</b>                | £31.27       | <b>£22.51</b> |

**Bent**



| Type | Capacity | Weight each | Order Code<br><b>IND-445</b> | List Price/1 | Offer Price/1 |
|------|----------|-------------|------------------------------|--------------|---------------|
| Bent | 12.5mm   | 0.10kg      | <b>-9200K</b>                | £12.79       | <b>£9.21</b>  |
|      | 19.0mm   | 0.15kg      | <b>-9210K</b>                | £14.21       | <b>£10.23</b> |
|      | 25.0mm   | 0.30kg      | <b>-9220K</b>                | £17.05       | <b>£12.28</b> |
|      | 38.0mm   | 0.70kg      | <b>-9240K</b>                | £23.46       | <b>£16.89</b> |
|      | 50.0mm   | 1.50kg      | <b>-9260K</b>                | £33.41       | <b>£24.06</b> |

**KENNEDY**  
QUALITY INDUSTRIAL TOOLING

*Collection System  
Air Guns*

**Air Gun**

For general purpose use. 1/4" BSP male air inlet. 32mm ID bore conveying hose. Complete with dust bag.

| CFM @60psi | In | Out | CFM @100psi | In   | Out   |
|------------|----|-----|-------------|------|-------|
|            | 9  | 54  |             | 14.5 | 101.5 |



| Model Number | Weight each | Order Code<br><b>KEN-447</b> | List Price/1 | Offer Price/1 |
|--------------|-------------|------------------------------|--------------|---------------|
| VM 22K       |             | <b>-6010K</b>                | £54.48       | <b>£49.03</b> |

**Deep Hole Air Gun**

A plastic probe jets high pressure air into the hole to dislodge chips from blind holes up to 450mm deep. Shrouded nozzle prevents particles escaping and causing injury. 1/4" BSP male air inlet. 32mm ID bore conveying hose. Complete with dust bag.

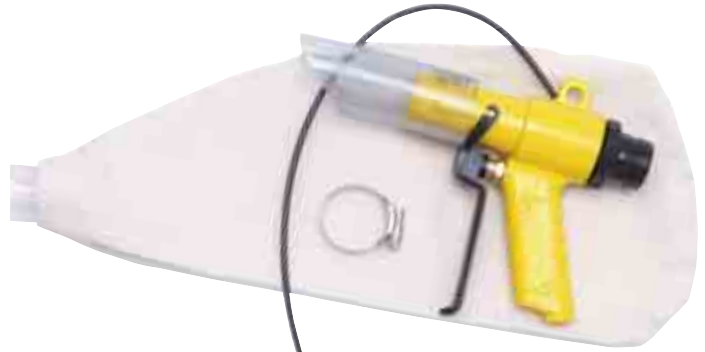

| Model Number | Weight each | Order Code<br><b>KEN-447</b> | List Price/1 | Offer Price/1 |
|--------------|-------------|------------------------------|--------------|---------------|
| VMDH 22K     |             | <b>-6030K</b>                | £71.03       | <b>£63.93</b> |

**Magnetic Distributor Base**

Base with hose connector, double threaded adaptor, two blanking plugs and 4x 1/4" NPT female outlets.

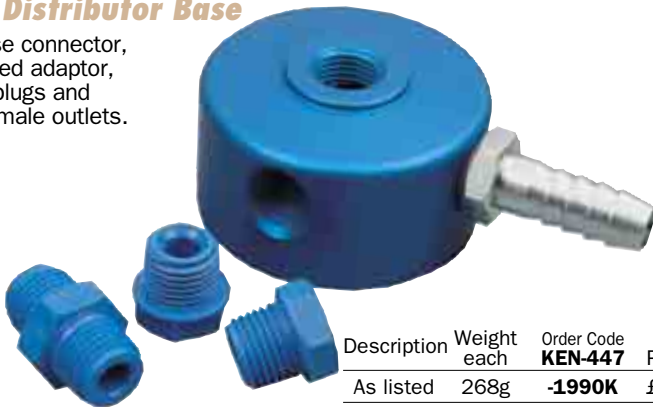

| Description | Weight each | Order Code<br><b>KEN-447</b> | List Price/1 | Offer Price/1 |
|-------------|-------------|------------------------------|--------------|---------------|
| As listed   | 268g        | <b>-1990K</b>                | £61.00       | <b>£54.90</b> |

**Air Gun Tool Kit**

For use with hand air guns. Kit comprises of: 454mm extension rod, 140mm flared nozzle (with removable brush), 60mm diameter round brush and a crevice tool.



| Model Number | Description | Order Code<br><b>KEN-447</b> | List Price/1 | Offer Price/1 |
|--------------|-------------|------------------------------|--------------|---------------|
| VM22-45      | 5m Hose     | <b>-6090K</b>                | £33.75       | <b>£30.38</b> |
| VMTK22       | Tool Kit    | <b>-6110K</b>                | £29.55       | <b>£26.59</b> |

**Air Pump**

For fixed installation, extending conveying range when used with hand air guns.



| Model Number | Weight each | Order Code<br><b>KEN-447</b> | List Price/1 | Offer Price/1 |
|--------------|-------------|------------------------------|--------------|---------------|
| VMAP 22      |             | <b>-6050K</b>                | £42.38       | <b>£38.14</b> |

**Dust Bag Kit**

For use with hand air guns. Complete with clip and crevice tool.



| Model Number | Weight each | Order Code<br><b>KEN-447</b> | List Price/1 | Offer Price/1 |
|--------------|-------------|------------------------------|--------------|---------------|
| VM 22-1      |             | <b>-6070K</b>                | £22.56       | <b>£20.30</b> |

Workshop Equipment

**KENNEDY** Modular Coolant Hose System  
QUALITY INDUSTRIAL TOOLING

Can be used with coolants, fluids and air lines. Suitable for all wet machining, spark erosion and air line operations up to 50PSI air and 30PSI liquid. Flow direction is easily and accurately positioned with no spring-back. All parts are fully interchangeable and fully replaceable. Manufactured from Acetal - non-conductive and chemical resistant. Available with 1/4", 1/2" and 3/4" bore. Hose is blue, all other fittings are orange. Threaded fittings are fully compatible with BSPT.



**Starter Packs**

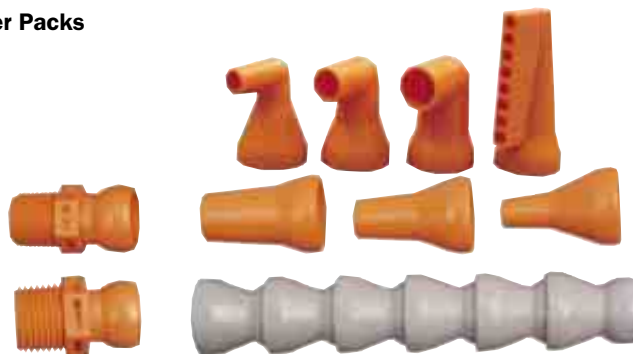

| Contents                         | Weight each | Order Code KEN-447 | List Price/1 | Offer Price/1 |
|----------------------------------|-------------|--------------------|--------------|---------------|
| <b>1/4" Bore</b>                 |             |                    |              |               |
| 11" Hose                         |             |                    |              |               |
| 3 x Nozzles                      | 70g         | -1910K             | £10.56       | <b>£9.50</b>  |
| 2 x Connectors                   |             |                    |              |               |
| 3 x 90° Nozzles & Spray          | 20g         | -1920K             | £7.93        | <b>£7.14</b>  |
| 4 each Extended Elements & Clips | 50g         | -1930K             | £17.62       | <b>£15.86</b> |
| <b>1/2" Bore</b>                 |             |                    |              |               |
| 11" Hose                         |             |                    |              |               |
| 3 x Nozzles                      | 110g        | -2910K             | £12.92       | <b>£11.63</b> |
| 2 x Connectors                   |             |                    |              |               |
| 3 x 90° Nozzles & Spray          | 40g         | -2920K             | £9.95        | <b>£8.96</b>  |
| 4 each Extended Elements & Clips | 90g         | -2930K             | £20.55       | <b>£18.50</b> |
| <b>3/4" Bore</b>                 |             |                    |              |               |
| 11" Hose                         |             |                    |              |               |
| 3 x Nozzles                      | 140g        | -3910K             | £15.04       | <b>£13.54</b> |
| 2 x Connectors                   |             |                    |              |               |

**Tube Segments**



| Bore Size                        | Weight each | Order Code KEN-447 | List Price/1 | Offer Price/1  |
|----------------------------------|-------------|--------------------|--------------|----------------|
| <b>Blue - 2 x 5 1/2" Lengths</b> |             |                    |              |                |
| 1 1/4"                           | 60g         | -1230K             | £7.89        | <b>£7.10</b>   |
| 1/2"                             | 80g         | -2230K             | £9.28        | <b>£8.35</b>   |
| 3/4"                             | 100g        | -3230K             | £11.39       | <b>£10.25</b>  |
| <b>Blue - 25ft Bulk Pack</b>     |             |                    |              |                |
| 1/4"                             | 1000g       | -1270K             | £151.84      | <b>£136.66</b> |
| 1/2"                             | 1900g       | -2270K             | £196.37      | <b>£176.73</b> |
| 3/4"                             | 2600g       | -3270K             | £247.97      | <b>£223.17</b> |

| Description                    | Bore Size | Weight each | Order Code KEN-447 | List Price/1 | Offer Price/1 |
|--------------------------------|-----------|-------------|--------------------|--------------|---------------|
| Blue Extended Element (Single) | 1/4"      | 10g         | -1280K             | £2.94        | <b>£2.65</b>  |
| Orange Element                 | 1/2"      | 20g         | -2280K             | £3.29        | <b>£2.96</b>  |
| Clamp (Single)                 | 1/4"      | 10g         | -1290K             | £2.19        | <b>£1.97</b>  |
|                                | 1/2"      | 20g         | -2290K             | £2.56        | <b>£2.30</b>  |

**INDEXA** Quick Set Machine Shields

14" (3/4" bore) hose length. Suitable for small machine tools. Fully adjustable with magnetic base.



| Visor Size               | Weight each | Order Code IND-447 | List Price/1 | Offer Price/1 |
|--------------------------|-------------|--------------------|--------------|---------------|
| <b>Shield (complete)</b> |             |                    |              |               |
| 6" x 8"                  | 500g        | -0250K             | £31.78       | <b>£27.01</b> |
| 7 1/2" x 10"             | 570g        | -0260K             | £34.10       | <b>£28.98</b> |
| <b>Replacement Visor</b> |             |                    |              |               |
| 6" x 8"                  | 200g        | -0350K             | £10.14       | <b>£8.62</b>  |
| 7 1/2" x 10"             | 250g        | -0360K             | £12.66       | <b>£10.76</b> |

**Quick Action Assembly Pliers**



| Bore Size | Weight each | Order Code IND-447 | List Price/1 | Offer Price/1 |
|-----------|-------------|--------------------|--------------|---------------|
| 1/4"      |             | -0010K             | £18.25       | <b>£15.51</b> |
| 1/2"      |             | -0020K             | £18.25       | <b>£15.51</b> |

**KENNEDY** Quick Set Machine Shield

14" (3/4" bore) hose length. Suitable for small machine tools. Protect from fluid splash and flying swarf. Fully adjustable with magnetic base. Not for use as a heavy duty enclosure guard on heavy duty milling machines.



| Visor Size               | Weight each | Order Code KEN-447 | List Price/1 | Offer Price/1 |
|--------------------------|-------------|--------------------|--------------|---------------|
| <b>Shield (Complete)</b> |             |                    |              |               |
| 6" x 8"                  | 500g        | -5250K             | £35.37       | <b>£31.83</b> |
| 7 1/2" x 10"             | 570g        | -5260K             | £37.96       | <b>£34.16</b> |
| 8 1/2" x 12"             | 640g        | -5270K             | £40.55       | <b>£36.49</b> |
| <b>Replacement Visor</b> |             |                    |              |               |
| 6" x 8"                  | 200g        | -5350K             | £11.29       | <b>£10.16</b> |
| 7 1/2" x 10"             | 250g        | -5360K             | £14.11       | <b>£12.70</b> |
| 8 1/2" x 12"             | 330g        | -5370K             | £16.91       | <b>£15.22</b> |

**Quick Action Assembly Pliers**

Specifically designed to allow quick easy assembly of Kennedy modular coolant hose.



| Bore Size | Weight each | Order Code KEN-447 | List Price/1 | Offer Price/1 |
|-----------|-------------|--------------------|--------------|---------------|
| 1/4"      | 110g        | -5010K             | £12.58       | <b>£11.32</b> |
| 1/2"      | 120g        | -5020K             | £12.58       | <b>£11.32</b> |

**CONTRACT PRICES AVAILABLE FOR VOLUME PURCHASES**

**Threaded Spigots**

Thread fittings fully compatible with BSPT.

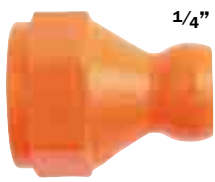

1/4" NPT Female Spigots



1/2" NPT Male Spigots

| Bore Size | Inlet Size      | Weight each | Order Code KEN-447 | List Price/1 | Offer Price/1 |
|-----------|-----------------|-------------|--------------------|--------------|---------------|
| 1/4"      | 1/4" SAE Female | 5g          | -1510K             | £1.97        | £1.77         |
| 1/4"      | 3/8" SAE Female | 10g         | -1520K             | £1.97        | £1.77         |
| 1/4"      | 1/8" NPT Male   | 5g          | -1170K             | £1.41        | £1.27         |
| 1/4"      | 1/4" NPT Male   | 10g         | -1190K             | £1.41        | £1.27         |
| 1/2"      | 3/8" NPT Male   | 10g         | -2170K             | £1.53        | £1.38         |
| 1/2"      | 1/2" NPT Male   | 10g         | -2190K             | £1.53        | £1.38         |
| 3/4"      | 3/4" NPT Male   | 10g         | -3170K             | £1.89        | £1.70         |

**Nozzles**



Spray 90°

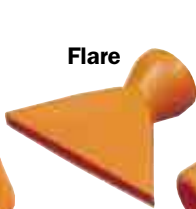

Flare



Pointed Straight



Pointed 90°

| Type               | Size   | Weight each | Order Code KEN-447 | List Price/1 | Offer Price/1 |
|--------------------|--------|-------------|--------------------|--------------|---------------|
| <b>1/4" Bore</b>   |        |             |                    |              |               |
| Pointed - Straight | 1/16"  | 5g          | -1610K             | £1.41        | £1.27         |
|                    | 1/8"   | 5g          | -1630K             | £1.41        | £1.27         |
|                    | 1/4"   | 5g          | -1650K             | £1.41        | £1.27         |
| Pointed 90°        | 1/16"  | 5g          | -1680K             | £1.84        | £1.66         |
|                    | 1/8"   | 5g          | -1690K             | £1.84        | £1.66         |
|                    | 1/4"   | 5g          | -1700K             | £1.84        | £1.66         |
| Spray - Straight   | .040"  | 10g         | -1560K             | £4.45        | £4.00         |
| Spray - 90°        | .060"  | 10g         | -1570K             | £4.45        | £4.00         |
| Flare              | .100"  | 10g         | -1580K             | £3.95        | £3.56         |
|                    | 1"     | 5g          | -1670K             | £4.13        | £3.72         |
| <b>1/2" Bore</b>   |        |             |                    |              |               |
| Pointed - Straight | 1/4"   | 5g          | -2610K             | £1.53        | £1.38         |
|                    | 3/8"   | 5g          | -2630K             | £1.53        | £1.38         |
|                    | 1/2"   | 5g          | -2650K             | £1.53        | £1.38         |
| Pointed - 90°      | 1/4"   | 5g          | -2700K             | £2.07        | £1.86         |
|                    | 3/8"   | 5g          | -2710K             | £2.07        | £1.86         |
|                    | 1/2"   | 5g          | -2720K             | £2.07        | £1.86         |
| Spray - 90°        | .170"  | 5g          | -2580K             | £4.99        | £4.49         |
| Flare              | 1 1/4" | 5g          | -2670K             | £4.69        | £4.22         |
|                    | 2 1/2" | 5g          | -2690K             | £5.40        | £4.86         |
| <b>3/4" Bore</b>   |        |             |                    |              |               |
| Pointed - Straight | 5/8"   | 10g         | -3610K             | £1.89        | £1.70         |
| Flare              | 3/4"   | 10g         | -3630K             | £1.89        | £1.70         |
|                    | 3"     | 10g         | -3650K             | £7.65        | £6.88         |

**Threaded Adaptor**

1/8" NPT Female.

Fully compatible with BSPT threads.



| Bore Size | Weight each | Order Code KEN-447 | List Price/1 | Offer Price/1 |
|-----------|-------------|--------------------|--------------|---------------|
| 1/4"      | 5g          | -1710K             | £1.77        | £1.59         |

**Modular Manifold Kits**

Allows a single line of coolant hose to be split off into four separate supplies.



| Description                                       | Bore Size | Weight each | Order Code KEN-447 | List Price/1 | Offer Price/1 |
|---|-----------|-------------|--------------------|--------------|---------------|
| 3x T-Pieces, 2x L-Piece, 1x Bracket and 3x Screws | 1/4"      | 50g         | -1450K             | £18.10       | £16.29        |
|   | 1/2"      | 70g         | -2450K             | £19.63       | £17.67        |

**Modular Coolant Hose System**

**Junction Pieces**



L-Piece



Y-Piece



T-Piece

| Type             | Weight each | Order Code KEN-447 | List Price/1 | Offer Price/1 |
|------------------|-------------|--------------------|--------------|---------------|
| <b>1/4" Bore</b> |             |                    |              |               |
| Y-Piece          | 10g         | -1310K             | £4.13        | £3.72         |
| T-Piece          | 10g         | -1350K             | £4.59        | £4.13         |
| L-Piece          | 10g         | -1370K             | £3.77        | £3.39         |
| <b>1/2" Bore</b> |             |                    |              |               |
| Y-Piece          | 10g         | -2310K             | £10.58       | £9.52         |
| T-Piece          | 10g         | -2350K             | £5.30        | £4.77         |
| L-Piece          | 10g         | -2370K             | £4.59        | £4.13         |
| <b>3/4" Bore</b> |             |                    |              |               |
| Y-Piece          | 10g         | -3310K             | £4.78        | £4.30         |

**Junction Reducers**

| Type             | Weight each | Order Code KEN-447 | List Price/1 | Offer Price/1 |
|------------------|-------------|--------------------|--------------|---------------|
| <b>1/2" Bore</b> |             |                    |              |               |
| 1/2" to 2 x 1/4" | 10g         | -2330K             | £4.69        | £4.22         |
| 1/2" to 1/4"     | 5g          | -2510K             | £3.41        | £3.07         |
| <b>3/4" Bore</b> |             |                    |              |               |
| 3/4" to 1/2"     | 10g         | -3330K             | £4.78        | £4.30         |
| 3/4" to 1/4"     | 10g         | -3510K             | £4.13        | £3.72         |

**Valves**

Thread fittings fully compatible with BSPT. In-line check valves stop fluid drip when flow stops, keeping hose full and reducing initial dry cutting.

Male Inlet



Female Inlet



| Bore Size                              | Inlet Size     | Weight each | Order Code KEN-447 | List Price/1 | Offer Price/1 |
|--|----------------|-------------|--------------------|--------------|---------------|
| <b>Plastic Type - 1/4 Turn Fitting</b> |                |             |                    |              |               |
| 1/4"                                   | 1/4 NPT Male   | 10g         | -1010K             | £6.82        | £6.14         |
| 1/4"                                   | 1/4 NPT Female | 10g         | -1030K             | £6.82        | £6.14         |
| 1/4"                                   | In-line        | 10g         | -1050K             | £6.82        | £6.14         |
| 1/2"                                   | 1/2 NPT Male   | 30g         | -2010K             | £8.23        | £7.41         |
| 1/2"                                   | 1/2 NPT Female | 30g         | -2030K             | £8.23        | £7.41         |
| 1/2"                                   | In-line        | 30g         | -2050K             | £8.23        | £7.41         |
| <b>Metal Type - Ball Fitting</b>       |                |             |                    |              |               |
| 1/4"                                   | 1/8 NPT Male   | 90g         | -1070K             | £4.35        | £3.92         |
| 1/4"                                   | 1/4 NPT Male   | 100g        | -1090K             | £4.35        | £3.92         |
| 1/2"                                   | 3/8 NPT Male   | 80g         | -2070K             | £4.13        | £3.72         |
| 1/2"                                   | 1/2 NPT Male   | 120g        | -2090K             | £4.13        | £3.72         |
| 3/4"                                   | 3/4 NPT Male   | 200g        | -3070K             | £7.88        | £7.09         |
| <b>Check Valves</b>                    |                |             |                    |              |               |
| 1/4"                                   | In-line        | 10g         | -1100K             | £6.63        | £5.97         |
| 1/2"                                   | In-line        | 10g         | -2100K             | £7.40        | £6.66         |

**Parallel Connectors & Reducers**

Thread fittings fully compatible with BSPT.

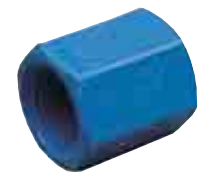

| Description            | Weight each | Order Code KEN-447 | List Price/1 | Offer Price/1 |
|------------------------|-------------|--------------------|--------------|---------------|
| <b>Double Socket</b>   |             |                    |              |               |
| 1/4" x 1/4" Bore       | 5g          | -1730K             | £1.53        | £1.38         |
| 1/2" x 1/2" Bore       | 5g          | -2730K             | £1.77        | £1.59         |
| <b>Parallel</b>        |             |                    |              |               |
| 1/8" x 1/8" NPT Female | 5g          | -1110K             | £1.29        | £1.16         |
| 1/4" x 1/4" NPT Female | 10g         | -1130K             | £1.29        | £1.16         |
| 3/8" x 3/8" NPT Female | 10g         | -2110K             | £1.53        | £1.38         |
| 1/2" x 1/2" NPT Female | 10g         | -2130K             | £2.46        | £2.21         |
| <b>Reducers</b>        |             |                    |              |               |
| 1/4" x 1/8" NPT Female | 10g         | -1140K             | £1.22        | £1.10         |
| 3/8" x 1/4" NPT Female | 10g         | -1150K             | £1.48        | £1.33         |
| 1/2" x 1/4" NPT Female | 10g         | -2140K             | £2.38        | £2.14         |

Workshop Equipment

## INDEXA Modular Coolant Hose System

Modular coolant hose system is ideal for coolants, fluids and air lines. Suitable for all wet machining, spark erosion and air line operations up to 50PSI air and 30PSI liquid. Flow direction is easily and accurately positioned with no spring-back. All parts are fully interchangeable and fully replaceable if a single section is damaged. Manufactured from acetal - non-conductive and chemical resistant. Available with 1/4", 1/2" and 3/4" bore. Hose is green, all other fittings are orange. Threaded fittings are fully compatible with BSPT.



### Starter Packs

| Contents         | Weight each | Order Code IND-447 | List Price/1 | Offer Price/1 |
|------------------|-------------|--------------------|--------------|---------------|
| <b>1/4" Bore</b> |             |                    |              |               |
| 12" Hose         |             |                    |              |               |
| 4 Nozzles        | 40g         | -6910K             | £9.48        | <b>£8.06</b>  |
| 2 Connectors     |             |                    |              |               |
| <b>1/2" Bore</b> |             |                    |              |               |
| 13" Hose         |             |                    |              |               |
| 3 Nozzles        | 91g         | -7910K             | £11.62       | <b>£9.88</b>  |
| 2 Connectors     |             |                    |              |               |
| <b>3/4" Bore</b> |             |                    |              |               |
| 14" Hose         |             |                    |              |               |
| 2 Nozzles        | 126g        | -8910K             | £13.51       | <b>£11.48</b> |
| 1 Connectors     |             |                    |              |               |

### Tube Segments



| Bore Size                     | Weight each | Order Code IND-447 | List Price/1 | Offer Price/1  |
|-------------------------------|-------------|--------------------|--------------|----------------|
| <b>11" Lengths (Green)</b>    |             |                    |              |                |
| 1/4"                          | 40g         | -6210K             | £7.09        | <b>£6.03</b>   |
| 1/2"                          | 69g         | -7210K             | £8.35        | <b>£7.10</b>   |
| 3/4"                          | 102g        | -8210K             | £10.23       | <b>£8.70</b>   |
| <b>11" Lengths (Blue)</b>     |             |                    |              |                |
| 3/4"                          | 102g        | -8230K             | £10.23       | <b>£8.70</b>   |
| <b>25ft Bulk Pack (Green)</b> |             |                    |              |                |
| 1/4"                          | 886g        | -6250K             | £135.78      | <b>£115.41</b> |
| 1/2"                          | 1637g       | -7250K             | £175.71      | <b>£149.35</b> |
| 3/4"                          | 2381g       | -8250K             | £222.49      | <b>£189.12</b> |
| <b>25ft Bulk Pack (Blue)</b>  |             |                    |              |                |
| 3/4"                          | 2381g       | -8270K             | £222.49      | <b>£189.12</b> |

### Modular Manifold Kits



| Description  | Bore Size | Weight each | Order Code IND-447 | List Price/1 | Offer Price/1 |
|--------------|-----------|-------------|--------------------|--------------|---------------|
| 4x T-Pieces, | 1/4"      | 109g        | -6450K             | £16.26       | <b>£13.82</b> |
| 2x Plug,     |           |             |                    |              |               |
| 1x Bracket,  | 1/2"      | 98g         | -7450K             | £17.63       | <b>£14.99</b> |
| 4x Screws    |           |             |                    |              |               |

## Modular Coolant Hose System

### Threaded Spigots

Male Spigot



| Bore Size | Inlet Size      | Weight each | Order Code IND-447 | List Price/1 | Offer Price/1 |
|-----------|-----------------|-------------|--------------------|--------------|---------------|
| 1/4"      | 1/8" NPT Female | 2g          | -6710K             | £1.58        | <b>£1.34</b>  |
|           | 1/4" NPT Female | 2g          | -6730K             | £1.58        | <b>£1.34</b>  |
| 1/4"      | 1/8" NPT Male   | 2g          | -6170K             | £1.27        | <b>£1.08</b>  |
|           | 1/4" NPT Male   | 2g          | -6190K             | £1.27        | <b>£1.08</b>  |
| 1/2"      | 3/8" NPT Male   | 7g          | -7170K             | £1.37        | <b>£1.16</b>  |
|           | 1/2" NPT Male   | 7g          | -7190K             | £1.37        | <b>£1.16</b>  |
| 3/4"      | 1/2" NPT Female | 7g          | -7730K             | £1.54        | <b>£1.31</b>  |
|           | 3/4" NPT Male   | 10g         | -8170K             | £1.69        | <b>£1.44</b>  |

### Nozzles

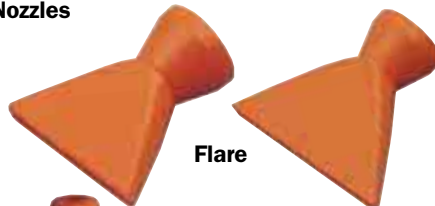

Flare

Pointed

| Type             | Size   | Weight each | Order Code IND-447 | List Price/1 | Offer Price/1 |
|------------------|--------|-------------|--------------------|--------------|---------------|
| <b>1/4" Bore</b> |        |             |                    |              |               |
| Pointed          | 1/16"  | 5g          | -6610K             | £1.27        | <b>£1.08</b>  |
|                  | 1/8"   | 5g          | -6630K             | £1.27        | <b>£1.08</b>  |
|                  | 3/1"   | 5g          | -6640K             | £1.27        | <b>£1.08</b>  |
|                  | 1/4"   | 5g          | -6650K             | £1.27        | <b>£1.08</b>  |
| Flare            | 1"     | 5g          | -6670K             | £3.70        | <b>£3.15</b>  |
| <b>1/2" Bore</b> |        |             |                    |              |               |
| Pointed          | 1/4"   | 5g          | -7610K             | £1.37        | <b>£1.16</b>  |
|                  | 3/8"   | 5g          | -7630K             | £1.37        | <b>£1.16</b>  |
|                  | 1/2"   | 5g          | -7650K             | £1.37        | <b>£1.16</b>  |
| Flare            | 1 3/4" | 5g          | -7670K             | £4.22        | <b>£3.59</b>  |
|                  | 2 1/2" | 5g          | -7690K             | £4.86        | <b>£4.13</b>  |
| <b>3/4" Bore</b> |        |             |                    |              |               |
| Pointed          | 5/8"   | 10g         | -8610K             | £1.69        | <b>£1.44</b>  |
| Flare            | 3/4"   | 10g         | -8630K             | £1.69        | <b>£1.44</b>  |
|                  | 3"     | 10g         | -8650K             | £6.86        | <b>£5.83</b>  |

### Plastic Valves

1/4 turn fitting.



| Bore Size | Inlet Type | Weight each | Order Code IND-447 | List Price/1 | Offer Price/1 |
|-----------|------------|-------------|--------------------|--------------|---------------|
| 1/4"      | In-line    | 10g         | -6050K             | £6.12        | <b>£5.20</b>  |
| 1/2"      | In-line    | 30g         | -7050K             | £7.39        | <b>£6.28</b>  |

### Metal Ball Valves

Threaded fitting 1/4 turn.



| NPT Threads Male x Female | Weight each | Order Code IND-447 | List Price/1 | Offer Price/1 |
|---------------------------|-------------|--------------------|--------------|---------------|
| 1/8" x 1/8"               | 81g         | -6070K             | £3.90        | <b>£3.31</b>  |
| 1/4" x 1/4"               | 80g         | -6090K             | £3.90        | <b>£3.31</b>  |
| 3/8" x 3/8"               | 76g         | -7070K             | £3.90        | <b>£3.31</b>  |
| 1/2" x 1/2"               | 114g        | -7090K             | £3.90        | <b>£3.31</b>  |
| 3/4" x 3/4"               |             | -8070K             | £7.08        | <b>£6.02</b>  |

## Modular Coolant XHose System

### Junction Pieces



L-Piece

Y-Piece

| Type             | Weight each | Order Code IND-447 | List Price/1 | Offer Price/1 |
|------------------|-------------|--------------------|--------------|---------------|
| <b>1/4" Bore</b> |             |                    |              |               |
| Y-Piece          | 3g          | -6310K             | £3.70        | <b>£3.15</b>  |
| T-Piece          | 3g          | -6350K             | £4.13        | <b>£3.51</b>  |
| L-Piece          | 4g          | -6370K             | £3.38        | <b>£2.87</b>  |
| <b>1/2" Bore</b> |             |                    |              |               |
| Y-Piece          | 9g          | -7310K             | £4.40        | <b>£3.74</b>  |
| T-Piece          | 9g          | -7350K             | £4.74        | <b>£4.03</b>  |
| L-Piece          | 12g         | -7370K             | £4.13        | <b>£3.51</b>  |

### Junction Reducers



| Type             | Weight each | Order Code IND-447 | List Price/1 | Offer Price/1 |
|------------------|-------------|--------------------|--------------|---------------|
| <b>1/2" Bore</b> |             |                    |              |               |
| 1/2" to 2 x 1/4" | 4g          | -7330K             | £4.22        | <b>£3.59</b>  |
| 1/2" to 1/4"     | 3g          | -7510K             | £3.06        | <b>£2.60</b>  |
| <b>3/4" Bore</b> |             |                    |              |               |
| 3/4" to 1/2"     | 5g          | -8510K             | £3.69        | <b>£3.14</b>  |

## KENNEDY Modular Coolant Hose System

### Circle Flow System



| Description                   | Bore Size | Weight each | Order Code KEN-447 | List Price/1 | Offer Price/1 |
|-------------------------------|-----------|-------------|--------------------|--------------|---------------|
| Kit: 15 Nozzles and 1 End Cap | 1/4"      | 120g        | -1950K             | £20.02       | <b>£18.02</b> |
|                               | 1/2"      | 200g        | -2950K             | £22.60       | <b>£20.34</b> |
| Single Nozzle                 | 1/4"      | 5g          | -1960K             | £1.89        | <b>£1.70</b>  |
|                               | 1/2"      | 5g          | -2960K             | £2.13        | <b>£1.92</b>  |
| End Cap                       | 1/4"      | 5g          | -1970K             | £1.12        | <b>£1.01</b>  |
|                               | 1/2"      | 5g          | -2970K             | £1.27        | <b>£1.14</b>  |

**GROUP 448 BENCH SHEARS & GUILLOTINE SHEARS**

**ATLAS WORKHOLDERS Bench Shears**

Hand operated, compound lever action bench shears. Capable of rapidly cutting through metal plate, strip and bar. Solid steel frame for rigidity and strength. With hardened and precision ground blades for accurate cutting. Adjustable blade guard.



**For Safety Glasses**

**See Group 960**

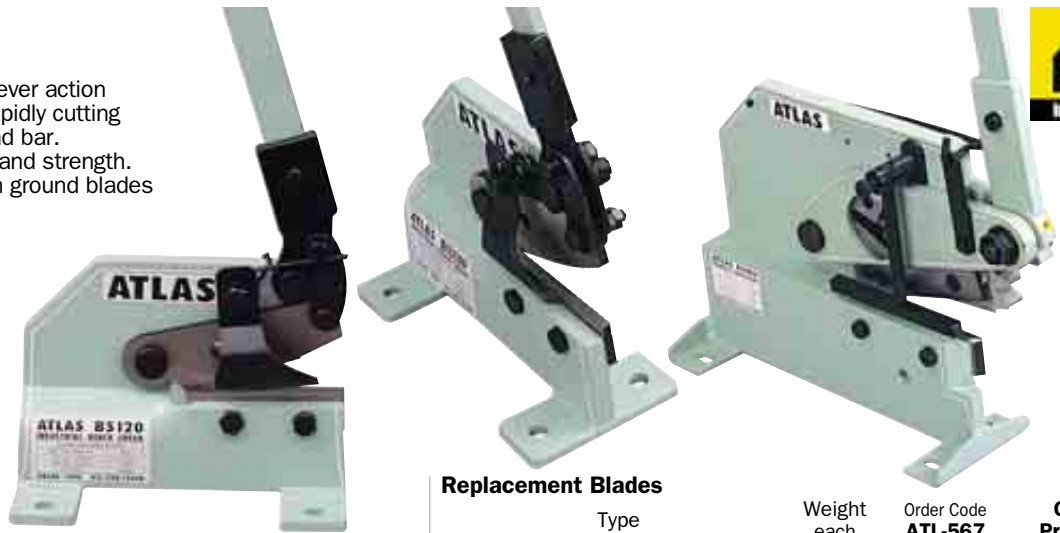

| Model Number | Plate | Maximum Strip | Bar | Jaw Width | Weight each | Order Code <b>ATL-448</b> | List Price/1 | <b>Offer Price/1</b> |
|--------------|-------|---------------|-----|-----------|-------------|---------------------------|--------------|----------------------|
| BS120        | 4mm   | 5 x 70        | 10  | 120       | 8.3kg       | <b>-1200K</b>             | £172.15      | <b>£111.90</b>       |
| BS200        | 6mm   | 7 x 70        | 13  | 200       | 19.0kg      | <b>-2000K</b>             | £307.54      | <b>£199.90</b>       |
| BS406        | 8mm   | 10 x 100      | 16  | 200       | 43.0kg      | <b>-3000K</b>             | £461.38      | <b>£299.90</b>       |

**Replacement Blades**

| Type                                 | Weight each | Order Code <b>ATL-567</b> | <b>Offer Price/1</b> |
|--------------------------------------|-------------|---------------------------|----------------------|
| Top Blade for ATL-448-1200K Shear    | 445g        | <b>-3100K</b>             | <b>£16.21</b>        |
| Bottom Blade for ATL-448-1200K Shear | 250g        | <b>-3110K</b>             | <b>£9.94</b>         |
| Top Blade for ATL-448-2000K Shear    | 1.4kg       | <b>-3150K</b>             | <b>£69.09</b>        |
| Bottom Blade for ATL-448-2000K Shear | 790g        | <b>-3160K</b>             | <b>£35.01</b>        |
| Top Blade for ATL-448-3000K Shear    | 430g        | <b>-3200K</b>             | <b>£28.37</b>        |
| Bottom Blade for ATL-448-3000K Shear | 220g        | <b>-3210K</b>             | <b>£36.86</b>        |

Workshop Equipment

**Ajax Scantool Guillotine Shears**

**NEW**

**TSM650:** Strong and compact welded steel construction. This modern bench model is hand-operated and very suitable for cutting metal and all other materials. The material being sheared is held in place by neoprene-coated clamps to prevent damage. The material is clamped before the blade cuts.

**TSM 1050:** Strong and compact welded steel construction. This model is foot-operated and very suitable for cutting metal and all other materials. The material being sheared is held in place by neoprene coated clamps to prevent damage. The material is clamped before the blade cuts. The knife is reversible and made of high-speed steel. It provides good visibility of the complete cutting length and is supplied with a light.

**TSP 1050/SC1250:** Manual back gauge with mm counter. Illumination of cutting edge. Safety equipment in accordance with CE. 600mm table extensions. Self-lubricating guides. Double eccentric drive on the cutter bar. Rubber-coated sheet holder. Low knife angle and burr-free cutting. Angle stop. Special equipment. Cutting counter. Motorised back gauge. Sheet catcher. Special blades for cutting stainless steel sheets. Table extension and angle stop with millimetre gauge and tilt stop. Adjustable angle stop with millimetre gauge and tilt stop.



**2 YEAR WARRANTY**

Also available with special blades, motorised back-gauge, cutting counter, table extensions, sheet catcher - For full details please contact your local branch.

| Model Number | Guillotine Type | Cuts Per Min. | Cutting Capacity Width x Thickness | Cutting Angle | Backgauge | Side Stop | Blade Style | Weight each | Order Code <b>AJX-448</b> | <b>Offer Price/1</b> |
|--------------|-----------------|---------------|------------------------------------|---------------|-----------|-----------|-------------|-------------|---------------------------|----------------------|
| TSM650       | Bench           | (manual)      | 650 x 1.25mm                       | 3°            | 550mm     | 200mm     | Plain       | 80kg        | <b>-8260Q</b>             | <b>£3391.00</b>      |
| TSM1050      | Floor Mounted   | (manual)      | 1030 x 1.25mm                      | 3°            | 600mm     | 200mm     | Plain       | 148kg       | <b>-8264V</b>             | <b>£4492.00</b>      |
| TSP1050      | Pneumatic       | 19 CPM        | 1030 x 2.00mm                      | 3°            | 550mm     | 200mm     | Plain       | 280kg       | <b>-8278K</b>             | <b>£8624.00</b>      |
| SC1250       | Motorised (3kW) | 38 CPM        | 1250 x 3.00mm                      | 2°            | 600mm     | 600mm     | Segmented   | 990kg       | <b>-7552G</b>             | <b>£16612.00</b>     |

**NEW**

**Ajax Scantool Bending Rolls**

All models cover the capacity range of 1.0mm to 3.0mm thickness with a rolling length of 1040mm, these heavily constructed all cast iron framed machines with high quality steel rolls have been designed for ease of operation, all rolls have wire grooves.



**MBR1050x1**



**MBR1050x3**

**2 YEAR WARRANTY**



**EBR1050x3**

| Model Number | Bending Capacity Width x Thickness | Roll Diameter | Operation Type | Rolling Speed | Nett Weight | Order Code AJX-448 | Offer Price/1 |
|--------------|------------------------------------|---------------|----------------|---------------|-------------|--------------------|---------------|
| MBR1050x1    | 1040 x 1.0mm                       | 56mm          | Hand           | (Manual)      | 200kg       | -5710B             | £2455.00      |
| MBR1050x3    | 1040 x 3.0mm                       | 75mm          | Hand           | (Manual)      | 620kg       | -5710D             | £7196.00      |
| EBR1050x3    | 1040 x 3.0mm                       | 90mm          | Motorised      | 6m/min        | 450kg       | -3345Z             | £8818.00      |

**Scantool Folding Machines**

**SCA600/SCA1050:** Upper beam with built-in camber which handles varying sheet thicknesses without adjustment. The distortion is adjustable.

**SCAN10S:** Heavy-duty bending machines with segment beam. Foot-operated upper beam allows hands free operation. A heavy-duty cylinder.

**SC1250SLMT:** Standard equipment: scale - for adjusting bend angles. Motor-operated upper beam. Motor-operated upper and bending beam. Complete bending process contained in one cycle. Electronic control of tension level in the upper beam. Prepared for retrofit of back gauge. Foot pedal with automatic safety device. Emergency stop.

**NEW**

**VERDICT Metal Folding Machine**

**SF600**

Suited for prototypes and general folding work. Can be bench-mounted or fitted to an optional stand (not included). Capable of interrupted or partial folds and able to shape scrolls and cylinders.

**Dimensions (W x D x H):**  
752 x 300 x 130mm.



**SCA600**



**SCA1050**



**SCAN10S**

**2 YEAR WARRANTY**



**SC1250SLMT**



Also available with manual back-gauge, back-gauge with digital display, round or sharp nose blades - For full details please contact your local branch.

| Model Number | Folding Capacity Width x Thickness | Folding Angle | Maximum Opening | Blade Style | Weight each | Order Code AJX-448 | Offer Price/1 |
|--------------|------------------------------------|---------------|-----------------|-------------|-------------|--------------------|---------------|
| SCA600       | 600 x 1.25mm                       | 135°          | 22mm            | Plain       | 25kg        | -7575G             | £551.00       |
| SCA1050      | 1050 x 1.50mm                      | 135°          | 35mm            | Plain       | 74kg        | -7579L             | £1386.00      |
| SCAN10S      | 1020 x 2.75mm                      | 135°          | 52mm            | Plain       | 310kg       | -7595D             | £2656.00      |
| SC1250SLMT   | 1270 x 2.00mm                      | 150°          | 30mm            | Segmented   | 690kg       | -7552S             | £20910.00     |

**For Gloves**



**See Group 961**

| Product Number | Weight each | Order Code | Offer Price/1 |
|----------------|-------------|------------|---------------|
| SF600          | 12kg        | -6600M     | £109.00       |

**CONTRACT PRICES AVAILABLE FOR VOLUME PURCHASES**

All Prices Exclude V.A.T. © 2013

**GROUP 450 TURNING & KNURLING TOOLS**

**KENNEDY** *Turning Tool Holders*  
QUALITY INDUSTRIAL TOOLING

Manufactured from high grade steel, machined and ground with black mottle finish. Tool bits are held parallel and straight to the shank giving maximum support to the cutting edge. Supplied with wrench but without tool bit.



**For Tool Bits**

**See Group 090**

| Size of Holder      | Size of Cut-off Blade | Weight each | Order Code <b>KEN-450</b> | List Price/1 | Offer Price/1 |
|---------------------|-----------------------|-------------|---------------------------|--------------|---------------|
| 3/4" x 1 3/4" x 9"  | 7/16"                 | 1.6kg       | <b>-0650K</b>             | £19.65       | <b>£15.72</b> |
| 7/8" x 1 7/8" x 10" | 1/2"                  | 2.2kg       | <b>-0660K</b>             | £24.09       | <b>£19.27</b> |
| 1" x 2 1/8" x 12"   | 5/8"                  | 3.4kg       | <b>-0680K</b>             | £33.82       | <b>£27.06</b> |

**JHL** *Six Knurl Toolholder*

Machine ground high grade steel, black mottle finish. Revolving head. Knurls available separately, see table below. For use with knurl size 3/4" x 3/8" x 1/4".



| Size                   | Knurls Fitted   | Weight each | Order Code <b>JHL-450</b> | Offer Price/1  |
|------------------------|-----------------|-------------|---------------------------|----------------|
| 1/2" x 1 1/8" x 6 1/2" | -1110B & -1210B | 640g        | <b>-8000A</b>             | <b>£148.99</b> |

*Two Knurl Toolholder*

Machine ground high grade steel, black mottle finish. Self-adjusting head. Knurls available separately, see table below. For use with knurl size 3/4" x 3/8" x 1/4".



| Size                 | Knurls Fitted   | Weight each | Order Code <b>JHL-450</b> | Offer Price/1 |
|----------------------|-----------------|-------------|---------------------------|---------------|
| 1/2" x 7/8" x 6 1/2" | -1110B & -1210B | 290g        | <b>-8020C</b>             | <b>£93.13</b> |

**3/4" x 3/8" x 1/4" Knurls to suit Toolholders above**

| Capacity (mm) | Weight each | Order Code <b>JHL-450</b> |               |               | Offer Price/1 |
|---------------|-------------|---------------------------|---------------|---------------|---------------|
|               |             | Coarse                    | Medium        | Fine          |               |
| Straight      | 10g         | <b>-1000A</b>             | <b>-1010B</b> | <b>-1020C</b> | <b>£8.60</b>  |
| Right Hand    | 10g         | <b>-1100A</b>             | <b>-1110B</b> | <b>-1120C</b> | <b>£8.60</b>  |
| Left Hand     | 10g         | <b>-1200A</b>             | <b>-1210B</b> | <b>-1220C</b> | <b>£8.60</b>  |
| Checkered     | 10g         | <b>-1300A</b>             | <b>-1310B</b> | <b>-1320C</b> | <b>£17.20</b> |

*Two Knurl Toolholder*

Side knurling up to a face or shoulder. Knurls available separately, see table below. For use with knurl size 25 x 10 x 16mm.



| Size           | Knurls Fitted   | Weight each | Order Code <b>JHL-450</b> | Offer Price/1  |
|----------------|-----------------|-------------|---------------------------|----------------|
| 20 x 25 x 85mm | -3110B & -3210B | 900g        | <b>-8040E</b>             | <b>£200.14</b> |

**25 x 10 x 16mm Knurls to suit Toolholder above**

| Capacity (mm) | Weight each | Order Code <b>JHL-450</b> |               |               | Offer Price/1 |
|---------------|-------------|---------------------------|---------------|---------------|---------------|
|               |             | Coarse                    | Medium        | Fine          |               |
| Straight      | 10g         | <b>-3000A</b>             | <b>-3010B</b> | <b>-3020C</b> | <b>£16.50</b> |
| Right Hand    | 10g         | <b>-3100A</b>             | <b>-3110B</b> | <b>-3120C</b> | <b>£16.50</b> |
| Left Hand     | 10g         | <b>-3200A</b>             | <b>-3210B</b> | <b>-3220C</b> | <b>£16.50</b> |

*Six Knurl Toolholder*

Machine ground high grade steel, black mottle finish. Revolving head. Knurls available separately, see table below. For use with knurl size 5/8" x 3/16" x 1/4".



| Size                 | Knurls Fitted   | Weight each | Order Code <b>JHL-450</b> | Offer Price/1  |
|----------------------|-----------------|-------------|---------------------------|----------------|
| 1/2" x 7/8" x 6 1/2" | -2610B & -2710B | 930g        | <b>-8010B</b>             | <b>£135.42</b> |

**5/8" x 3/16" x 1/4" Knurls to suit Toolholder above**

| Capacity (mm) | Weight each | Order Code <b>JHL-450</b> |               |               | Offer Price/1 |
|---------------|-------------|---------------------------|---------------|---------------|---------------|
|               |             | Coarse                    | Medium        | Fine          |               |
| Straight      | 10g         | <b>-2500A</b>             | <b>-2510B</b> | <b>-2520C</b> | <b>£6.89</b>  |
| Right Hand    | 10g         | <b>-2600A</b>             | <b>-2610B</b> | <b>-2620C</b> | <b>£6.89</b>  |
| Left Hand     | 10g         | <b>-2700A</b>             | <b>-2710B</b> | <b>-2720C</b> | <b>£6.89</b>  |
| Checkered     | 10g         | <b>-2800A</b>             | <b>-2810B</b> | -             | <b>£8.60</b>  |

*Two Knurl Toolholder*

Machine ground high grade steel, black mottle finish. Self-adjusting head. Knurls available separately, see table below. For use with knurl size 5/8" x 5/16" x 7/32".



**Knurls supplied separately**

| Size                 | Knurls Fitted       | Weight each | Order Code <b>JHL-450</b> | Offer Price/1 |
|----------------------|---------------------|-------------|---------------------------|---------------|
| 3/8" x 7/8" x 5 1/2" | Supplied separately | 390g        | <b>-8030D</b>             | <b>£82.72</b> |

**5/8" x 5/16" x 7/32" Knurls to suit Toolholder above**

| Capacity (mm) | Weight each | Order Code <b>JHL-450</b> |               |               | Offer Price/1 |
|---------------|-------------|---------------------------|---------------|---------------|---------------|
|               |             | Coarse                    | Medium        | Fine          |               |
| Straight      | 10g         | <b>-2000A</b>             | <b>-2010B</b> | <b>-2020C</b> | <b>£8.26</b>  |
| Right Hand    | 10g         | <b>-2100A</b>             | <b>-2110B</b> | <b>-2120C</b> | <b>£8.26</b>  |
| Left Hand     | 10g         | <b>-2200A</b>             | <b>-2210B</b> | <b>-2220C</b> | <b>£8.26</b>  |
| Checkered     | 10g         | <b>-2300A</b>             | <b>-2310B</b> | <b>-2320C</b> | <b>£9.97</b>  |

*Single Knurl Toolholder*

Machine ground high grade steel, black mottle finish. Knurls available separately, see table below. For use with knurl size 3/4" x 1/4" x 1/4".



| Size             | Knurls Fitted | Weight each | Order Code <b>JHL-450</b> | Offer Price/1 |
|------------------|---------------|-------------|---------------------------|---------------|
| 1/2" x 1/2" x 4" | -1510B        | 140g        | <b>-8050F</b>             | <b>£30.39</b> |

**3/4" x 1/4" x 1/4" Knurls to suit Toolholder above**

| Capacity (mm) | Weight each | Order Code <b>JHL-450</b> |               |               | Offer Price/1 |
|---------------|-------------|---------------------------|---------------|---------------|---------------|
|               |             | Coarse                    | Medium        | Fine          |               |
| Straight      | 10g         | <b>-1500A</b>             | <b>-1510B</b> | <b>-1520C</b> | <b>£7.68</b>  |
| Right Hand    | 10g         | <b>-1600A</b>             | <b>-1610B</b> | <b>-1620C</b> | <b>£7.68</b>  |
| Left Hand     | 10g         | <b>-1700A</b>             | <b>-1710B</b> | <b>-1720C</b> | <b>£8.26</b>  |
| Checkered     | 10g         | <b>-1800A</b>             | <b>-1810B</b> | <b>-1820C</b> | <b>£8.26</b>  |

Workshop Equipment

MACHINE GUARDS/LATHE CHUCKS

**CLEERVUE** Silvaflame Mill  
Co Ltd Guards

Steel tubular frame and 5mm thick polycarbonate visors for heavy duty applications. Complies with **BS EN 292 : 1993** and **BS 5304 : 1988**.

**Enclosure Mill Guards**

Quick release plunger pin allows each section to swing aside for instant access. Can be installed on any make of milling machine. Supplied with T-slot and bolts. Model **EM/1** has one hinged side and front panel, right hand opening as standard (if left hand is required please state when ordering). Model **EM/3** has two equal size panels.



| Product Number | To Suit Table Size | Height (mm) | Order Code               | Offer Price/1  |
|----------------|--------------------|-------------|--------------------------|----------------|
| EM/1           | 600 - 1000         | 400         | <b>SIL-455</b><br>-1010K | <b>£436.50</b> |
| EM/3           | 1000 - 1500        | 400         | <b>-1030K</b>            | <b>£582.75</b> |

**Grinding Machine Guards**

All comply with the Abrasive Wheels Regulations, the Protection of Eye Regulations 1974 and have been tested to **BS 2092 Grade 1**.



| Product Number | Frame Size (mm) | Recommended for Wheel Size | Order Code               | Offer Price/1 |
|----------------|-----------------|----------------------------|--------------------------|---------------|
| SGB            | 159 x 133       | 127 - 200mm                | <b>SIL-455</b><br>-1500K | <b>£17.50</b> |
| ST             | 215 x 150       | 200 - 280mm                | <b>-1520K</b>            | <b>£29.00</b> |
| ST/1           | 324 x 305       | 305mm +                    | <b>-1540K</b>            | <b>£67.00</b> |

**Spare Visors**

| Product Number | To Suit Frame Size | Type | Order Code               | Offer Price/1 |
|----------------|--------------------|------|--------------------------|---------------|
| 130004         | 159 x 133          | SGB  | <b>SIL-455</b><br>-1510K | <b>£9.40</b>  |

**Drill & Chuck Guards**

Self-adjusting telescopic action for full operator from quill to drill point. Scratch resistant polycarbonate visors. The lower section can be removed to allow use with shorter drills. For use with drills with a collar size of 50 to 88mm diameter. Supplied with two bush blanks which can be turned on the O/D to the size of the collar and split along pre-marked line before inserting into guard.



**Bush sizes:** 88 x 50mm and 88 x 70mm.  
**Minimum length:** 115mm.  
**Overall length:** Full 265mm, using two sections 186mm.

| Product Number | Weight each | Order Code               | Offer Price/1 |
|----------------|-------------|--------------------------|---------------|
| MT/RB          |             | <b>SIL-455</b><br>-2010K | <b>£85.00</b> |

**INDEXA** Self-Centring Geared Scroll Lathe Chucks

Produced to a well proven design for universal application. Scrolls are forged, balanced and hardened. Thread flanks are ground on both sides. All models have grease nipples for easy lubrication and are supplied with two sets of solid jaws - internal and external stepped.

**Cast Iron 3 Jaw Plain Back Chuck DIN 6350 (form A)**

Three jaw plain back with adaptor recess.

**Type 3204**

Rear mounting.

**Type 3274**

Front mounting.

**Type 3275**

Front mounting, reversible jaws.

**Type 3504**

Steel. Rear mounting.



Type 3204



Type 3275



Type 3504

| Chuck Size (mm) | Thru Hole | Type 3204 |        | Type 3274 |         | Type 3275 |         | Type 3504 |         | List Price/1 | Offer Price/1 |
|-----------------|-----------|-----------|--------|-----------|---------|-----------|---------|-----------|---------|--------------|---------------|
|                 |           | Rr Mnt    | Fr Mnt | Fr Mnt    | Fr Mnt  | Rr Mnt    | Rr Mnt  |           |         |              |               |
| 80              | 16        | -1010K    | -      | £171.00   | £133.38 | -         | -       | -         | -       | -            | -             |
| 85              | 18        | -         | -1220K | £180.00   | £140.40 | -         | -       | -         | -       | -            | -             |
| 100             | 20        | -1030K    | -      | £183.00   | £142.74 | -         | -       | -1630K    | £266.00 | £207.48      | -             |
| 125             | 32        | -1040K    | -1240K | £210.00   | £163.80 | -         | -       | -         | -       | -            | -             |
| 160             | 42        | -1060K    | -1260K | £254.00   | £198.12 | -1460K    | £281.00 | £219.18   | -1660K  | £327.00      | £255.06       |
| 200             | 55        | -1070K    | -1270K | £296.00   | £230.88 | -1470K    | £334.00 | £260.52   | -1670K  | £398.00      | £310.44       |
| 250             | 76        | -1080K    | -1280K | £408.00   | £318.24 | -1480K    | £446.00 | £347.88   | -1680K  | £571.00      | £445.38       |
| 315             | 103       | -1090K    | -1290K | £628.00   | £489.84 | -         | -       | -         | -       | -            | -             |
| 400             | 136       | -1100K    | -      | £979.00   | £763.62 | -         | -       | -         | -       | -            | -             |

**Cast Iron Taper Mount Type Chucks - Short Taper 1 : 4**

DIN 55029, DIN 55022 & ASA B.5.9.

Three jaw plain back with adaptor recess.

**Type 3244**

Camlock mounted on a short taper (1 : 4).



| Chuck Size (mm) | Taper Size | Through Hole | Order Code | List Price/1 | Offer Price/1 |
|-----------------|------------|--------------|------------|--------------|---------------|
| 160             | 3          | 42           | -3160K     | £324.00      | £252.72       |
| 160             | 4          | 42           | -3170K     | £324.00      | £252.72       |
| 200             | 4          | 55           | -3200K     | £398.00      | £310.44       |
| 250             | 6          | 76           | -3350K     | £526.00      | £410.28       |

**Independent Jaw Lathe Chucks**

Independently adjustable jaws. This allows firm gripping of irregular shaped work and the four jaws allow a square component to be perfectly centred to the chuck while achieving maximum gripping force. The chuck bodies are made of steel (sizes 85 - 160mm) or high quality cast iron (sizes 200 - 800mm). The jaws are made of high quality carbon steel and hardened. Thrust bearings and operating screws are made of case hardened steel. Supplied with reversible solid jaws, internal and external stepped. With T-slots.

**Cast Iron 4 Jaw Plain Back Chuck**

DIN 6351.

**Type 4304**

Plain back with adaptor recess. Front mounted.



| Chuck Size (mm) | Through Hole | Weight each | Order Code | List Price/1 | Offer Price/1 |
|-----------------|--------------|-------------|------------|--------------|---------------|
| 200             | 50           | 14kg        | -5050K     | £293.00      | £228.54       |
| 250             | 65           | 25kg        | -5060K     | £330.00      | £257.40       |
| 500             | 125          | 105kg       | -5100K     | £910.00      | £709.80       |
| 630             | 160          | 163kg       | -5110K     | £1293.00     | £1008.54      |

**Taper Mount 4 Jaw Type Chuck - Short Taper 1 : 4**

DIN 55029.

**Type 4344**

Front mounting on a short taper.



| Chuck Size (mm) | Taper Size | Through Hole | Weight each | Order Code | List Price/1 | Offer Price/1 |
|-----------------|------------|--------------|-------------|------------|--------------|---------------|
| 160             | 3          | 42           | 6kg         | -5810K     | £434.00      | £338.52       |

A range of quality traditional workholding equipment. Manufactured from high quality steel and case hardened all over. All sleeves and sockets are fully hardened and ground internally and externally.  
**ISO 238 BS 1660 : 2.**

**Morse Taper Sleeve Data**

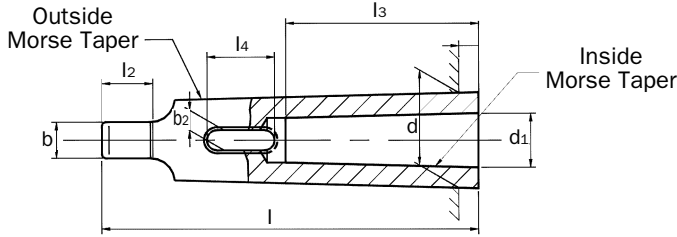

| MT | Inside | Outside | l      | d      | b      | l2     | d1     | l3      | l4     | b2     |
|----|--------|---------|--------|--------|--------|--------|--------|---------|--------|--------|
| 1  | 2      | 3       | 92.00  | 17.780 | 6.350  | 11.112 | 12.065 | 52.388  | 19.050 | 5.410  |
| 1  | 3      | 4       | 99.00  | 23.825 | 7.938  | 14.288 | 12.065 | 52.388  | 19.050 | 5.410  |
| 2  | 4      | 5       | 112.00 | 23.825 | 7.938  | 14.288 | 17.780 | 63.500  | 22.225 | 6.604  |
| 1  | 4      | 5       | 124.00 | 31.267 | 11.906 | 15.875 | 12.065 | 52.388  | 19.050 | 5.410  |
| 2  | 4      | 5       | 124.00 | 31.267 | 11.906 | 15.875 | 17.780 | 63.500  | 22.225 | 6.604  |
| 3  | 4      | 5       | 140.00 | 31.267 | 11.906 | 15.875 | 23.825 | 77.788  | 30.162 | 8.179  |
| 1  | 5      | 6       | 156.00 | 44.399 | 15.875 | 19.050 | 12.065 | 52.388  | 19.050 | 5.410  |
| 2  | 5      | 6       | 156.00 | 44.399 | 15.875 | 19.050 | 17.780 | 63.500  | 22.225 | 6.604  |
| 3  | 5      | 6       | 156.00 | 44.399 | 15.875 | 19.050 | 23.825 | 77.788  | 30.162 | 8.179  |
| 4  | 5      | 6       | 171.00 | 44.399 | 15.875 | 19.050 | 31.267 | 98.425  | 31.750 | 12.141 |
| 1  | 6      | 7       | 218.00 | 63.348 | 19.050 | 28.575 | 12.065 | 52.388  | 19.050 | 5.410  |
| 2  | 6      | 7       | 218.00 | 63.348 | 19.050 | 28.575 | 17.780 | 63.500  | 22.225 | 6.604  |
| 3  | 6      | 7       | 218.00 | 63.348 | 19.050 | 28.575 | 23.825 | 77.788  | 30.162 | 8.179  |
| 4  | 6      | 7       | 218.00 | 63.348 | 19.050 | 28.575 | 31.267 | 98.425  | 31.750 | 12.141 |
| 5  | 6      | 7       | 218.00 | 63.348 | 19.050 | 28.575 | 44.399 | 125.412 | 38.100 | 16.129 |

**Drill Sleeves**



| Taper            | Length | Weight | Order Code | List    | Offer   |
|------------------|--------|--------|------------|---------|---------|
| Inside x Outside | (mm)   | each   | KEN-482    | Price/1 | Price/1 |
| 1 x 2 MT         | 95     | 110g   | -2120K     | £17.18  | £10.31  |
| 1 x 3 MT         | 97     | 220g   | -2130K     | £19.93  | £11.96  |
| 1 x 4 MT         | 120    | 560g   | -2140K     | £30.40  | £18.24  |
| 1 x 5 MT         | 152    | 1500g  | -2150K     | £61.41  | £36.85  |
| 2 x 3 MT         | 110    | 200g   | -2230K     | £19.93  | £11.96  |
| 2 x 4 MT         | 123    | 490g   | -2240K     | £30.40  | £18.24  |
| 2 x 5 MT         | 155    | 1500g  | -2250K     | £74.01  | £44.41  |
| 3 x 4 MT         | 140    | 430g   | -2340K     | £30.84  | £18.50  |
| 3 x 5 MT         | 155    | 1200g  | -2350K     | £74.01  | £44.41  |
| 4 x 5 MT         | 170    | 1100g  | -2450K     | £74.01  | £44.41  |
| 4 x 6 MT         | 215    | 3600g  | -2460K     | £162.00 | £97.20  |
| 5 x 6 MT         | 225    | 2800g  | -2560K     | £162.00 | £97.20  |

**'Use-Em-Up' Sleeves**

For re-using taper shank drills where the tang has broken off.



| Taper            | Length | Weight | Order Code | List    | Offer   |
|------------------|--------|--------|------------|---------|---------|
| Inside x Outside | (mm)   | each   | KEN-482    | Price/1 | Price/1 |
| 3 x 4 MT         | 135    | 135g   | -8340K     | £41.55  | £24.93  |

**Extension Sockets**



| Taper            | Length | Weight | Order Code | List    | Offer   |
|------------------|--------|--------|------------|---------|---------|
| Inside x Outside | (mm)   | each   | KEN-482    | Price/1 | Price/1 |
| 1 x 1 MT         | 145    | 275g   | -4110K     | £47.63  | £28.58  |
| 1 x 2 MT         | 160    | 290g   | -4120K     | £54.07  | £32.44  |
| 2 x 1 MT         | 175    | 300g   | -4210K     | £50.39  | £30.23  |
| 2 x 2 MT         | 175    | 390g   | -4220K     | £55.93  | £33.56  |
| 2 x 3 MT         | 194    | 710g   | -4230K     | £62.86  | £37.72  |
| 3 x 2 MT         | 194    | 620g   | -4320K     | £58.25  | £34.95  |
| 3 x 3 MT         | 230    | 750g   | -4330K     | £64.72  | £38.83  |
| 3 x 4 MT         | 255    | 1400g  | -4340K     | £72.12  | £43.27  |
| 4 x 3 MT         | 255    | 1500g  | -4430K     | £81.78  | £49.07  |
| 4 x 5 MT         | 300    | 3000g  | -4450K     | £114.00 | £68.40  |
| 5 x 4 MT         | 300    | 2500g  | -4540K     | £118.00 | £70.80  |

**Turret Sockets**



| Inside Morse Taper | Outside Diameter | Overall Length | Weight each | Order Code KEN-482 | List Price/1 | Offer Price/1 |
|--------------------|------------------|----------------|-------------|--------------------|--------------|---------------|
| No.1               | 3/4"             | 3 1/4"         | 138g        | -5100K             | £66.74       | £40.04        |
| No.1               | 1"               | 3 1/2"         | 307g        | -5120K             | £38.10       | £22.86        |
| No.1               | 1 1/4"           | 3 1/2"         | 511g        | -5140K             | £82.36       | £49.42        |
| No.1               | 1 1/2"           | 3 1/2"         | 748g        | -5160K             | £53.26       | £31.96        |
| No.2               | 1"               | 4"             | 274g        | -5210K             | £38.10       | £22.86        |
| No.2               | 1 1/4"           | 4"             | 504g        | -5220K             | £53.61       | £32.17        |
| No.2               | 1 1/2"           | 4"             | 791g        | -5230K             | £47.38       | £28.43        |
| No.2               | 1 3/4"           | 4"             | 1105g       | -5240K             | £79.75       | £47.85        |
| No.2               | 2 1/8"           | 4"             | 1703g       | -5260K             | £78.49       | £47.09        |
| No.3               | 1 1/4"           | 4 3/4"         | 460g        | -5310K             | £50.94       | £30.56        |
| No.3               | 1 1/2"           | 4 3/4"         | 800g        | -5320K             | £50.99       | £30.59        |
| No.3               | 1 3/4"           | 4 3/4"         | 1175g       | -5330K             | £68.44       | £41.06        |
| No.3               | 2"               | 4 3/4"         | 1672g       | -5340K             | £84.16       | £50.50        |
| No.3               | 2 1/8"           | 4 3/4"         | 1373g       | -5350K             | £91.69       | £55.01        |
| No.3               | 2 1/2"           | 4 3/4"         | 2710g       | -5360K             | £101.00      | £60.60        |
| No.4               | 1 1/2"           | 6"             | 632g        | -5420K             | £64.07       | £38.44        |
| No.4               | 1 3/4"           | 6"             | 1239g       | -5430K             | £95.91       | £57.55        |
| No.4               | 2"               | 6"             | 1819g       | -5440K             | £90.14       | £54.08        |
| No.4               | 2 1/2"           | 6"             | 3125g       | -5460K             | £131.00      | £78.60        |
| No.5               | 2 1/2"           | 8"             | 3069g       | -5560K             | £153.00      | £91.80        |
| No.1               | 16               | 90mm           | 97g         | -6100K             | £56.48       | £33.89        |
| No.1               | 20               | 90mm           | 174g        | -6110K             | £54.57       | £32.74        |
| No.1               | 25               | 95mm           | 312g        | -6120K             | £55.44       | £33.26        |
| No.1               | 30               | 115mm          | 594g        | -6130K             | £60.79       | £36.47        |
| No.2               | 25               | 95mm           | 236g        | -6220K             | £45.12       | £27.07        |
| No.2               | 30               | 115mm          | 509g        | -6230K             | £60.90       | £36.54        |
| No.2               | 40               | 125mm          | 1162g       | -6240K             | £65.44       | £39.26        |
| No.2               | 50               | 135mm          | 1948g       | -6250K             | £85.59       | £51.35        |
| No.3               | 40               | 135mm          | 903g        | -6340K             | £68.55       | £41.13        |
| No.3               | 60               | 185mm          | 3853g       | -6360K             | £101.00      | £60.60        |
| No.4               | 40               | 155mm          | 963g        | -6440K             | £81.21       | £48.73        |
| No.4               | 50               | 175mm          | 2055g       | -6450K             | £103.00      | £61.80        |
| No.4               | 60               | 185mm          | 3464g       | -6460K             | £109.00      | £65.40        |
| No.5               | 50               | 175mm          | 3410g       | -6550K             | £108.00      | £64.80        |

**Drill Drifts**

To release Morse Taper Tooling without damaging machine socket or tools.



| To Release Morse Taper | Weight each | Order Code KEN-482 | List Price/1 | Offer Price/1 |
|------------------------|-------------|--------------------|--------------|---------------|
| 0                      | 40g         | -9500K             | £3.81        | £2.29         |
| 1 & 2                  | 80g         | -9520K             | £4.60        | £2.76         |
| 3                      | 220g        | -9530K             | £8.24        | £4.94         |
| 3 & 5                  | 380g        | -9540K             | £10.74       | £6.44         |
| 5 & 6                  | 760g        | -9560K             | £18.96       | £11.38        |

**Drill Sleeve & Drift Set**

Set of three drill sleeves 1 - 2, 2 - 3, 3 - 4 MT. Fully hardened and ground inside and out. Two drill drifts to release 1 - 2 and 3 - 4 MT.



**5**  
PIECES

| No. of Pieces | Weight Set | Order Code KEN-482 | List Price/1 | Offer Price/1 |
|---------------|------------|--------------------|--------------|---------------|
| 5             | 995g       | -9900K             | £52.51       | £31.51        |

Workshop Equipment

**KENNEDY** Standard-Duty Revolving Centres  
QUALITY INDUSTRIAL TOOLING

Manufactured from high alloy steel hardened and tempered then precision ground externally. Precision bearings are fitted as standard and the centres have a 60° point. Mounting Tapers are accurate to **DIN228** Form A, Tolerance Class AT5.

**Maximum runout:**  
No.1 to 4 taper: 0.005mm.  
No.5 to 6 taper: 0.010mm.



| Morse Taper | Max rpm | Radial Load (rpm) @100 (kgf) | Radial Load (rpm) @max (kgf) | Axial Load (rpm) @100 (kgf) | Axial Load (rpm) @3000 (kgf) | Weight each | Order Code KEN-488 | List Price/1 | Offer Price/1 |
|-------------|---------|------------------------------|------------------------------|-----------------------------|------------------------------|-------------|--------------------|--------------|---------------|
| No.1        | 7000    | 80                           | 32                           | 250                         | 50                           | 0.37kg      | -1010K             | £62.59       | £45.69        |
| No.2        | 7000    | 200                          | 55                           | 275                         | 60                           | 0.43kg      | -1020K             | £74.39       | £54.30        |
| No.3        | 6000    | 300                          | 70                           | 400                         | 70                           | 0.67kg      | -1030K             | £87.18       | £63.64        |
| No.4        | 5000    | 600                          | 75                           | 500                         | 125                          | 1.23kg      | -1040K             | £116.50      | £85.05        |
| No.5        | 4000    | 800                          | 280                          | 570                         | 230                          | 3.00kg      | -1050K             | £173.25      | £126.47       |

**Heavy-Duty Revolving Centres**

Manufactured from high alloy steel, heat treated and precision ground. Fitted with heavy-duty precision taper roller and thrust bearings to support both radial and axial loads. The 60° point is ground after assembly for absolute concentricity. Designed for heavy load and high production applications where durability is the main criteria. Mounting Tapers are accurate to **DIN228** Form A, Tolerance Class AT5.

**Maximum runout:**  
No.2 to 5 taper: 0.005mm.  
No.6 taper: 0.010mm.



| Morse Taper | Max rpm | Radial Load (rpm) @100 (kgf) | Radial Load (rpm) @max (kgf) | Axial Load (rpm) @100 (kgf) | Axial Load (rpm) @3000 (kgf) | Weight each | Order Code KEN-488 | List Price/1 | Offer Price/1 |
|-------------|---------|------------------------------|------------------------------|-----------------------------|------------------------------|-------------|--------------------|--------------|---------------|
| No.2        | 5500    | 260                          | 82                           | 580                         | 190                          | 0.59kg      | -2020K             | £106.75      | £77.93        |
| No.3        | 4000    | 480                          | 180                          | 810                         | 270                          | 1.35kg      | -2030K             | £120.75      | £88.15        |
| No.4        | 3000    | 800                          | 270                          | 1300                        | 400                          | 2.69kg      | -2040K             | £160.25      | £116.98       |
| No.5        | 2500    | 1050                         | 500                          | 1600                        | 490                          | 5.64kg      | -2050K             | £230.50      | £168.26       |

**Industrial Solid Centres**

Manufactured from high quality tool steel, hardened and ground with 60° point and spanner flats as standard. Mounting Tapers are accurate to **DIN228** Form A, Tolerance Class AT5.



| Morse Taper | Diameter (mm) | Across Flats | Length (mm) | Weight each | Order Code KEN-487 | List Price/1 | Offer Price/1 |
|-------------|---------------|--------------|-------------|-------------|--------------------|--------------|---------------|
| No.1        | 12.20         | 10           | 78          | 60g         | -1010K             | £6.20        | £5.08         |
| No.2        | 18.00         | 13           | 90          | 200g        | -1020K             | £7.71        | £6.32         |
| No.3        | 24.10         | 19           | 138         | 300g        | -1030K             | £8.81        | £7.22         |
| No.4        | 31.60         | 24           | 138         | 450g        | -1040K             | £15.50       | £12.71        |

**ATLAS** Standard-Duty Revolving Centres  
WORKHOLDERS

Manufactured from high alloy steel hardened and tempered then precision ground externally. Precision bearings are fitted as standard and the centres have a 60° point.

**Maximum runout:** 0.005mm.



**REVOLVING & SOLID CENTRES**

**Standard-Duty Interchangeable Revolving Centre Sets**



Manufactured from high alloy steel, precision ground internally and externally with pre-lubricated bearings. A versatile revolving centre with interchangeable points for a wide variety of applications. Ideal for toolroom or manufacture of small turned components. Points fit into body by means of a taper and are removed by use of the drift key supplied. All mating surfaces are precision ground and the set is supplied in a varnished wooden storage box.

| Morse Taper | Axial Load at 100rpm | Radial Load at 100rpm | Max rpm | Max Runout |
|-------------|----------------------|-----------------------|---------|------------|
| No. 2       | 200Kgf               | 100Kgf                | 4000    | 0.005mm    |
| No. 3       | 400Kgf               | 200Kgf                | 3000    | 0.005mm    |



| Morse Taper | Length (mm) | Diameter (mm) | Weight each | Order Code KEN-488 | List Price/1 | Offer Price/1 |
|-------------|-------------|---------------|-------------|--------------------|--------------|---------------|
| No.2        | 124         | 33            | 0.85kg      | -1320K             | £130.25      | £95.08        |
| No.3        | 152         | 42            | 1.10kg      | -1330K             | £147.25      | £107.49       |

**Interchangeable Points**

A complete range of interchangeable points to complement the revolving centre sets.

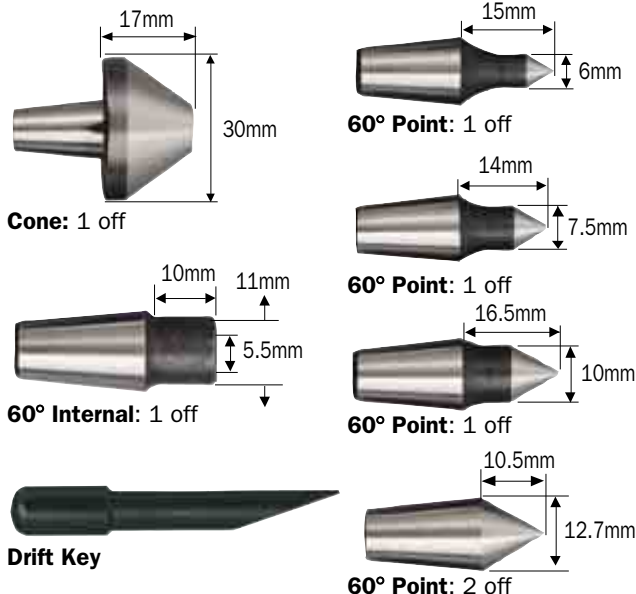

| Description               | Weight each | Order Code KEN-489 | Offer Price/1 |
|---------------------------|-------------|--------------------|---------------|
| 70° Cone x 30mm Dia.      | 90g         | -1010K             | £21.73        |
| 60° Point x 6mm Dia.      | 20g         | -1020K             | £14.81        |
| 60° Point x 7.5mm Dia.    | 20g         | -1030K             | £14.81        |
| 60° Point x 10mm Dia.     | 25g         | -1040K             | £14.81        |
| 60° Point x 12.7mm Dia.   | 20g         | -1050K             | £14.81        |
| 60° Internal x 5.5mm Dia. | 20g         | -1060K             | £14.81        |
| Drift Key                 | 20g         | -1100K             | £8.83         |

Workshop Equipment



**CONTRACT PRICES AVAILABLE FOR VOLUME PURCHASES**

For greater flexibility. Bodies and points manufactured from hardened and ground high grade tool steel, for improved resistance to wear extending tool operating life. Precision manufactured bearings evenly distribute axial load for smooth operation, reducing friction and heat build up. The bearings are protected by seals to prevent dirt and coolant ingress. Modern bevel head design allows unhindered approach of toolholders and lathe tools to the workpiece.

**Type 614 A**

Supplied without inserts.

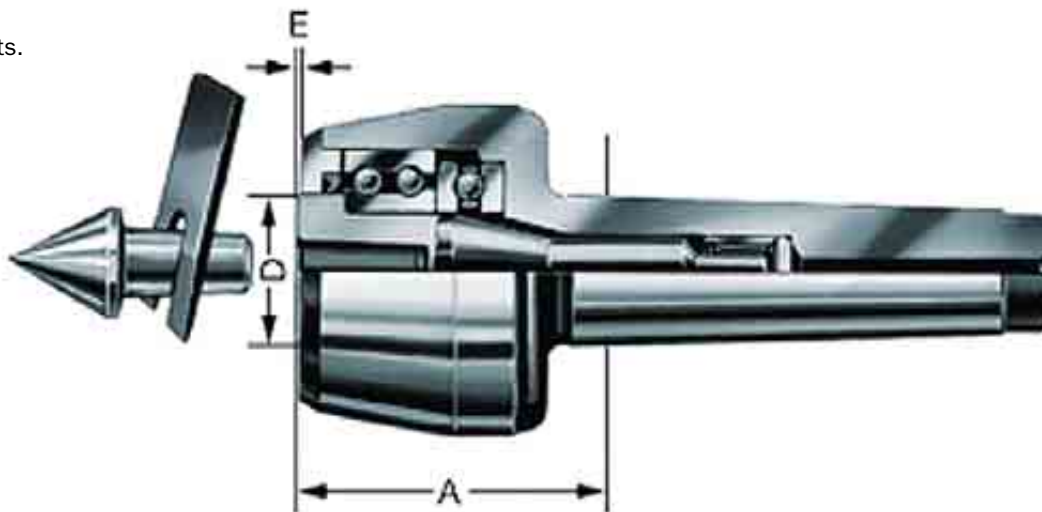

| Model Number | Morse Taper | Concentre Max Error | Workpiece Max Weight | Dimensions (mm) |    |     | Weight each | Order Code ROM-488 | List Price/1 | Offer Price/1  |
|--------------|-------------|---------------------|----------------------|-----------------|----|-----|-------------|--------------------|--------------|----------------|
|              |             |                     |                      | A               | D  | E   |             |                    |              |                |
| 061030       | 2           | 0.010               | 40kg                 | 45              | 20 | 4.0 | 0.44kg      | <b>-4020K</b>      | £165.41      | <b>£132.33</b> |
| 061031       | 3           | 0.010               | 130kg                | 48              | 22 | 4.5 | 0.75kg      | <b>-4030K</b>      | £184.65      | <b>£147.72</b> |
| 061032       | 3           | 0.010               | 150kg                | 55              | 25 | 5.0 | 1.10kg      | <b>-4035K</b>      | £208.12      | <b>£166.50</b> |
| 061038       | 4           | 0.010               | 250kg                | 67              | 32 | 5.0 | 1.90kg      | <b>-4040K</b>      | £280.12      | <b>£224.10</b> |
| 061039       | 5           | 0.010               | 650kg                | 85              | 40 | 6.0 | 4.40kg      | <b>-4050K</b>      | £400.27      | <b>£320.22</b> |

**Inserts**

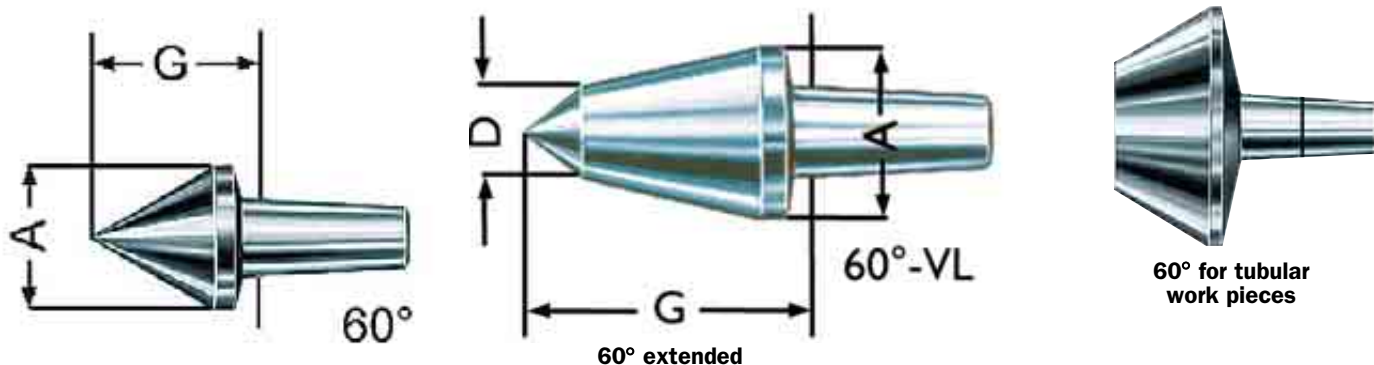

| Model Number | Insert Degree | Suitable for Morse Taper | Dimensions (mm) |      |      | Weight each | Order Code ROM-488 | List Price/1 | Offer Price/1 |
|--------------|---------------|--------------------------|-----------------|------|------|-------------|--------------------|--------------|---------------|
|              |               |                          | A               | D    | G    |             |                    |              |               |
| 070728       |               | 3                        | 20              | -    | 24.0 | 45g         | <b>-4830K</b>      | £19.97       | <b>£15.98</b> |
| 070734       | 60°           | 4                        | 28              | -    | 31.5 | 215g        | <b>-4840K</b>      | £26.74       | <b>£21.39</b> |
| 070737       |               | 5                        | 38              | -    | 43.0 | 250g        | <b>-4850K</b>      | £34.73       | <b>£27.78</b> |
| 070720       | 60°           | 3                        | 18              | 8.0  | 30.0 | 50g         | <b>-4730K</b>      | £26.74       | <b>£21.39</b> |
| 070721       | Extended      | 4                        | 26              | 12.0 | 43.0 | 120g        | <b>-4740K</b>      | £32.07       | <b>£25.66</b> |
| 070722       |               | 5                        | 32              | 13.0 | 55.0 | 255g        | <b>-4750K</b>      | £42.47       | <b>£33.98</b> |
| 070701       | 60°           | 3                        | 35              | 15.0 | 26.0 | 125g        | <b>-4530K</b>      | £32.07       | <b>£25.66</b> |
| 070703       | Tubular       | 4                        | 55              | 30.0 | 31.5 | 375g        | <b>-4540K</b>      | £50.46       | <b>£40.37</b> |
| 070739       | 90°           | 56                       | 38              | -    | 29.0 | 215g        | <b>-5050K</b>      | £34.73       | <b>£27.78</b> |

**60° Inserts for Centreless Workpieces**

| Model Number | Suitable for Morse Taper | Dimensions (mm) |    |    |    | Weight each | Order Code ROM-488 | List Price/1 | Offer Price/1 |
|--------------|--------------------------|-----------------|----|----|----|-------------|--------------------|--------------|---------------|
|              |                          | G               | L  | M  | N  |             |                    |              |               |
| 228621       | 3                        | 16              | 22 | 18 | 10 | 140g        | <b>-5530K</b>      | £52.15       | <b>£41.72</b> |

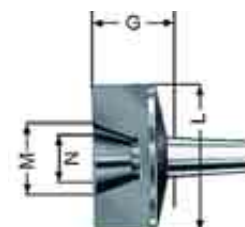

**Insert Extractor Tool**

| Product Number | Morse Taper | Weight each | Order Code ROM-488 | List Price/1 | Offer Price/1 |
|----------------|-------------|-------------|--------------------|--------------|---------------|
| 061707         | 2           |             | <b>-4120K</b>      | £10.89       | <b>£8.71</b>  |
| 061708         | 3/4         |             | <b>-4130K</b>      | £24.44       | <b>£19.55</b> |
| 061709         | 5/6         |             | <b>-4150K</b>      | £26.38       | <b>£21.10</b> |





Manufactured from hardened and ground high grade tool steel, for improved resistance to wear extending tool operating life. Precision manufactured bearings evenly distribute axial load for smooth operation, reducing friction and heat build up. The bearings are protected by seals to prevent dirt and coolant ingress. Modern bevel head design allows unhindered approach of toolholders and lathe tools to the workpiece.

**Type 600**  
With small case diameter.

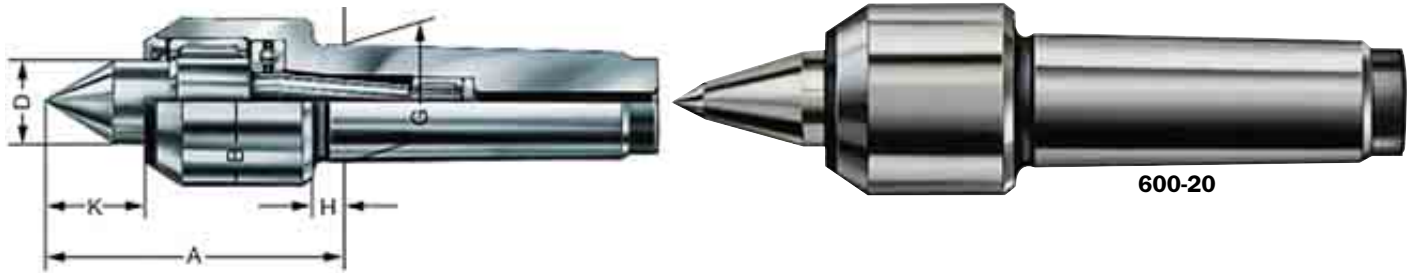

| Model Number | Morse Taper | Concentre Max Error | Workpiece Max Weight | Max. rpm | Dimensions (mm) |    |    |       |     |    | Weight each | Order Code ROM-488 | List Price/1 | Offer Price/1 |
|--------------|-------------|---------------------|----------------------|----------|-----------------|----|----|-------|-----|----|-------------|--------------------|--------------|---------------|
|              |             |                     |                      |          | A               | B  | D  | G     | H   | K  |             |                    |              |               |
| 005336       | 2           | 0.005               | 200kg                | 7000     | 62.0            | 32 | 15 | 17.78 | 7.0 | 18 | 0.3kg       | -2020K             | £133.46      | £106.77       |
| 005429       | 3           | 0.005               | 400kg                | 7000     | 62.0            | 34 | 15 | 23.85 | 7.0 | 18 | 0.4kg       | -2030K             | £144.11      | £115.29       |
| 005469       | 4           | 0.005               | 800kg                | 6300     | 75.5            | 42 | 20 | 31.26 | 8.5 | 25 | 1.0kg       | -2040K             | £176.06      | £140.85       |
| 005490       | 5           | 0.010               | 1600kg               | 4300     | 104.0           | 58 | 30 | 44.39 | 9.0 | 34 | 2.6kg       | -2050K             | £253.50      | £202.80       |

**Type 600-20**  
With extended live centre.

| Model Number | Morse Taper | Concentre Max Error | Workpiece Max Weight | Max. rpm | Dimensions (mm) |    |    |       |     |    | Weight each | Order Code ROM-488 | List Price/1 | Offer Price/1 |
|--------------|-------------|---------------------|----------------------|----------|-----------------|----|----|-------|-----|----|-------------|--------------------|--------------|---------------|
|              |             |                     |                      |          | A               | B  | D  | G     | H   | K  |             |                    |              |               |
| 362080       | 2           | 0.008               | 170                  | 7000     | 73              | 32 | 17 | 17.78 | 7.0 | 29 | 0.3kg       | -2120K             | £157.30      | £125.84       |
| 362081       | 3           | 0.008               | 340                  | 7000     | 74              | 34 | 15 | 23.83 | 7.0 | 30 | 0.4kg       | -2130K             | £166.86      | £133.49       |
| 362082       | 4           | 0.008               | 700                  | 6300     | 88.5            | 42 | 20 | 31.26 | 8.5 | 38 | 1.0kg       | -2140K             | £206.79      | £165.43       |
| 362083       | 5           | 0.010               | 1400                 | 4300     | 119.0           | 58 | 30 | 44.39 | 9.0 | 49 | 2.6kg       | -2150K             | £314.84      | £251.87       |

**Type 601 N**  
Standard



| Model Number | Morse Taper | Concentre max Error | Workpiece Max Weight | Max. rpm | Dimensions (mm) |    |    |       |     |      | Weight each | Order Code ROM-488 | List Price/1 | Offer Price/1 |
|--------------|-------------|---------------------|----------------------|----------|-----------------|----|----|-------|-----|------|-------------|--------------------|--------------|---------------|
|              |             |                     |                      |          | A               | B  | D  | G     | H   | K    |             |                    |              |               |
| 043111       | 2           | 0.005               | 180kg                | 7000     | 65.0            | 45 | 20 | 17.18 | 7.0 | 24.0 | 0.5kg       | -2320K             | £125.36      | £100.29       |
| 042310       | 3           | 0.005               | 300kg                | 6300     | 70.5            | 50 | 22 | 23.82 | 6.5 | 27.5 | 0.8kg       | -2330K             | £136.13      | £108.90       |
| 042171       | 4           | 0.005               | 750kg                | 3800     | 102.5           | 70 | 25 | 31.26 | 8.5 | 41.0 | 2.3kg       | -2340K             | £220.22      | £176.18       |
| 042839       | 5           | 0.005               | 1800kg               | 3000     | 129.0           | 90 | 40 | 44.39 | 8.5 | 50.5 | 4.7kg       | -2350K             | £340.25      | £272.20       |

**Type 602**

| Model Number | Morse Taper | Concentre max Error | Workpiece Max Weight | Max. rpm | Dimensions (mm) |    |    |       |   |    | Weight each | Order Code ROM-488 | List Price/1 | Offer Price/1 |
|--------------|-------------|---------------------|----------------------|----------|-----------------|----|----|-------|---|----|-------------|--------------------|--------------|---------------|
|              |             |                     |                      |          | A               | B  | D  | G     | H | K  |             |                    |              |               |
| 536361       | 2           | 0.01                | 150kg                | 4000     | 60              | 48 | 22 | 17.78 | 7 | 22 | 0.5kg       | -6010K             | £107.80      | £86.24        |

**Type 604 H**  
Hardened and ground body.

| Model Number | Morse Taper | Concentre max Error | Workpiece Max Weight | Max. rpm | Dimensions (mm) |     |    |       |      |      | Weight each | Order Code ROM-488 | List Price/1 | Offer Price/1 |
|--------------|-------------|---------------------|----------------------|----------|-----------------|-----|----|-------|------|------|-------------|--------------------|--------------|---------------|
|              |             |                     |                      |          | A               | B   | D  | G     | H    | K    |             |                    |              |               |
| 042315       | 3           | 0.005               | 400kg                | 6300     | 70.5            | 50  | 22 | 23.82 | 6.5  | 27.5 | 0.8kg       | -2230K             | £153.43      | £122.74       |
| 042175       | 4           | 0.005               | 800kg                | 3800     | 102.5           | 70  | 32 | 31.26 | 8.5  | 41.0 | 2.3kg       | -2240K             | £240.19      | £192.15       |
| 042843       | 5           | 0.005               | 2000kg               | 3000     | 129.0           | 90  | 40 | 44.39 | 8.5  | 50.5 | 4.7kg       | -2250K             | £373.53      | £298.82       |
| 043532       | 6           | 0.010               | 3500kg               | 2600     | 152.0           | 105 | 50 | 63.34 | 13.0 | 57.5 | 10.2kg      | -2260K             | £680.38      | £544.30       |

**Type 604 HVL**  
With extended live centre.



| Model Number | Morse Taper | Concentre max Error | Workpiece Max Weight | Max. rpm | Dimensions (mm) |    |    |       |     |    | Weight each | Order Code ROM-488 | List Price/1 | Offer Price/1 |
|--------------|-------------|---------------------|----------------------|----------|-----------------|----|----|-------|-----|----|-------------|--------------------|--------------|---------------|
|              |             |                     |                      |          | A               | B  | D  | G     | H   | K  |             |                    |              |               |
| 058670       | 3           | 0.005               | 400kg                | 5000     | 95.5            | 60 | 25 | 23.82 | 6.5 | 47 | 1.3kg       | -2490K             | £226.75      | £181.40       |
| 058671       | 4           | 0.005               | 500kg                | 3800     | 114.5           | 70 | 32 | 31.26 | 8.5 | 53 | 2.3kg       | -2500K             | £273.58      | £218.86       |
| 058672       | 5           | 0.005               | 1200kg               | 3000     | 143.5           | 90 | 40 | 44.39 | 8.5 | 65 | 4.8kg       | -2510K             | £413.58      | £330.86       |

**CONTRACT PRICES AVAILABLE FOR VOLUME PURCHASES**

**To Suit Pratt Burnard Chucks**  
For Standard, Super Precision, Griptru, All steel (type 78), Pratt Burnard old type (Inch) and Hardinge chucks.

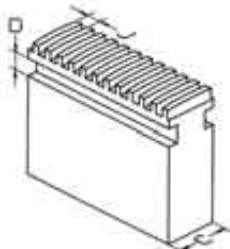

| Chuck Type                         | Jaw Code (Refer to Diameter)     |
|------------------------------------|----------------------------------|
| Standard, Griptru, Super Precision | <b>B, C, E, G, J, M, P, Q, R</b> |
| All Steel (Type 78)                | <b>L, O</b>                      |
| Burnard                            | <b>I, K, N</b>                   |
| Pratt Old Type                     | <b>H</b>                         |
| Hardinge/Pratt Type                | <b>F</b>                         |

**3 Jaw Sets**



4 and 6 jaw sets available on request

| Jaw Code | Dimensions (mm) |       |       |       | Order Code KEN-490 | List Price/1 | Offer Price/1 |
|----------|-----------------|-------|-------|-------|--------------------|--------------|---------------|
|          | Chuck Diameter  | C     | D     | J     |                    |              |               |
| EJB      | 80mm            | 9.40  | 4.85  | 4.24  | -1020K             | £21.65       | £19.92        |
| EJC      | 100mm           | 14.10 | 4.85  | 5.08  | -1030K             | £21.90       | £20.15        |
| EJE      | 125mm           | 15.75 | 8.03  | 6.35  | -1050K             | £22.00       | £20.24        |
| EJF      | 125mm           | 14.10 | 4.85  | 6.35  | -1060K             | £27.40       | £25.21        |
| EJG      | 160mm           | 18.79 | 8.03  | 6.35  | -1070K             | £25.10       | £23.09        |
| EJH      | 150mm           | 18.39 | 8.03  | 8.46  | -1080K             | £48.90       | £44.99        |
| EJI      | 180/200/230mm   | 25.02 | 9.70  | 8.46  | -1090K             | £51.50       | £47.38        |
| EJJ      | 200mm           | 20.62 | 9.53  | 8.46  | -1100K             | £27.95       | £25.71        |
| EJL      | 230mm           | 25.40 | 9.52  | 8.46  | -1120K             | £46.50       | £42.78        |
| EJM      | 250mm           | 25.40 | 11.10 | 8.46  | -1130K             | £36.70       | £33.76        |
| EJN      | 270/305mm       | 31.37 | 12.88 | 8.46  | -1140K             | £62.50       | £57.50        |
| EJO      | 310mm           | 30.15 | 11.43 | 8.46  | -1150K             | £63.95       | £58.83        |
| EJP      | 315mm           | 28.19 | 12.88 | 8.46  | -1160K             | £46.45       | £42.73        |
| EJQ      | 380mm           | 30.15 | 11.43 | 10.16 | -1170K             | £67.80       | £62.38        |
| EJR      | 460/535/610mm   | 38.10 | 14.30 | 12.70 | -1180K             | £127.50      | £117.30       |

**Serrated Soft Jaws**

To suit metric serrated power chucks (Kitagawa, Howa, Matsumoto, Pratt Burnard, SMW and Autoblok etc.).

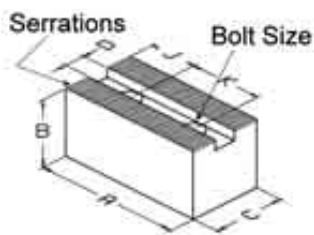

| Jaw Code | Chuck Diameter | Dimensions (mm) |     |    |    | K/J Bolt  | Serrations | Order Code KEN-490 | List Price/1 | Offer Price/1 |
|----------|----------------|-----------------|-----|----|----|-----------|------------|--------------------|--------------|---------------|
|          |                | A               | B   | C  | D  |           |            |                    |              |               |
| B004     | 100mm          | 48              | 25  | 20 | 8  | 15/8/M6   | 1.5mm x 60 | -5540K             | £14.50       | £13.34        |
| BR05     | 100/110/135mm  | 50              | 25  | 25 | 10 | 14/10/M8  | 1.5mm x 60 | -5670K             | £21.20       | £19.50        |
| B005     | 135mm          | 57              | 35  | 25 | 10 | 18/10/M8  | 1.5mm x 60 | -5550K             | £22.80       | £20.98        |
| B006     | 165mm          | 72              | 38  | 32 | 12 | 20/15/M10 | 1.5mm x 60 | -5560K             | £15.80       | £14.54        |
| DJ06     | 165mm          | 72              | 57  | 32 | 12 | 20/15/M10 | 1.5mm x 60 | -5860K             | £21.80       | £20.06        |
| PT06     | 165mm          | 82              | 30  | 32 | 12 | 20/15/M10 | 1.5mm x 60 | -2060K             | £20.50       | £18.86        |
| B008     | 210mm          | 95              | 40  | 32 | 14 | 25/25/M12 | 1.5mm x 60 | -5580K             | £17.55       | £16.15        |
| DJ08     | 210mm          | 95              | 70  | 32 | 14 | 25/25/M12 | 1.5mm x 60 | -5880K             | £30.65       | £28.20        |
| PT08     | 210mm          | 102             | 40  | 32 | 14 | 25/20/M12 | 1.5mm x 60 | -2080K             | £26.20       | £24.10        |
| B010     | 254mm          | 110             | 40  | 40 | 16 | 30/30/M12 | 1.5mm x 60 | -5600K             | £19.65       | £18.08        |
| DJ10     | 254mm          | 110             | 80  | 40 | 16 | 30/30/M12 | 1.5mm x 60 | -5900K             | £36.15       | £33.26        |
| DK10     | 254mm          | 90              | 60  | 40 | 16 | 30/21/M12 | 1.5mm x 60 | -5970K             | £25.25       | £23.23        |
| PT10     | 254mm          | 125             | 40  | 40 | 16 | 30/30/M12 | 1.5mm x 60 | -2100K             | £29.65       | £27.28        |
| DK11     | 254mm          | 110             | 60  | 40 | 16 | 30/21/M12 | 1.5mm x 60 | -5980K             | £45.05       | £41.45        |
| B012     | 315mm          | 130             | 50  | 50 | 18 | 30/40/M14 | 1.5mm x 60 | -5620K             | £28.90       | £26.59        |
| DJ12     | 315mm          | 130             | 80  | 50 | 18 | 30/40/M14 | 1.5mm x 60 | -5920K             | £53.45       | £49.17        |
| PT12     | 315mm          | 145             | 50  | 50 | 18 | 30/40/M14 | 1.5mm x 60 | -2120K             | £46.40       | £42.69        |
| BR13     | 315mm          | 130             | 50  | 50 | 21 | 30/40/M16 | 1.5mm x 60 | -5700K             | £28.75       | £26.45        |
| DJ13     | 315mm          | 130             | 80  | 50 | 21 | 30/40/M16 | 1.5mm x 60 | -5930K             | £53.45       | £49.17        |
| PT13     | 315mm          | 145             | 50  | 50 | 21 | 30/40/M16 | 1.5mm x 60 | -2130K             | £46.40       | £42.69        |
| B015     | 380mm          | 165             | 76  | 64 | 22 | 43/37/M20 | 1.5mm x 60 | -5650K             | £67.95       | £62.51        |
| DJ15     | 380mm          | 165             | 127 | 64 | 22 | 43/37/M20 | 1.5mm x 60 | -5950K             | £149.50      | £137.54       |
| B018     | 454/530/610mm  | 180             | 76  | 64 | 25 | 60/40/M20 | 3mm x 60   | -5660K             | £113.30      | £104.24       |
| DJ18     | 454/530/610mm  | 180             | 127 | 64 | 25 | 60/40/M20 | 3mm x 60   | -5960K             | £177.60      | £163.39       |

**Scroll Jaws**

To suit Pratt Burnard metric chucks (Standard Accuracy and Super Precision).

**3 Jaw Sets**



**4 and 6 jaw sets available on request**

| Jaw Code | Dimensions (mm) |    |    |    | Order Code KEN-490 | List Price/1 | Offer Price/1 |
|----------|-----------------|----|----|----|--------------------|--------------|---------------|
|          | Chuck Diameter  | C  | D  | J  |                    |              |               |
| EK08     | 80mm            | 10 | 5  | 6  | -6000K             | £21.25       | £19.55        |
| EK10     | 100mm           | 14 | 7  | 6  | -6010K             | £21.50       | £19.78        |
| EK13     | 125mm           | 16 | 7  | 6  | -6020K             | £21.70       | £19.96        |
| EK16     | 160mm           | 18 | 7  | 6  | -6030K             | £24.75       | £22.77        |
| EK20     | 200mm           | 22 | 8  | 8  | -6040K             | £27.45       | £25.25        |
| EK25     | 250mm           | 25 | 8  | 8  | -6050K             | £36.00       | £33.12        |
| EK32     | 315mm           | 32 | 12 | 10 | -6060K             | £46.45       | £42.73        |
| EK40     | 400mm           | 32 | 12 | 12 | -6070K             | £67.60       | £62.19        |

**Scroll Jaws**

To suit Toolmex and Bison chucks.

**3 Jaw Sets**



| Jaw Code | Dimensions (mm) |    |    |    | Order Code KEN-490 | List Price/1 | Offer Price/1 |
|----------|-----------------|----|----|----|--------------------|--------------|---------------|
|          | Chuck Diameter  | C  | D  | J  |                    |              |               |
| EN08     | 80mm            | 11 | 6  | 4  | -6180K             | £26.00       | £23.92        |
| EN10     | 100mm           | 15 | 6  | 6  | -6200K             | £18.80       | £17.30        |
| EN13     | 125mm           | 20 | 8  | 7  | -6220K             | £22.40       | £20.61        |
| EN16     | 160mm           | 20 | 8  | 8  | -6230K             | £26.20       | £24.10        |
| EN20     | 200mm           | 25 | 10 | 8  | -6240K             | £29.70       | £27.32        |
| EN25     | 250mm           | 28 | 12 | 9  | -6250K             | £38.70       | £35.60        |
| EN32     | 315mm           | 32 | 12 | 10 | -6260K             | £52.50       | £48.30        |



**KENNEDY** Slot/Tenon  
QUALITY INDUSTRIAL TOOLING Soft Jaws

To suit quick jaw change chucks (Berg, Forkardt, Gamet, Kitagawa, Reishauer, Rohm, Schunk and SMW-Autoblock).

**3 Piece Set**

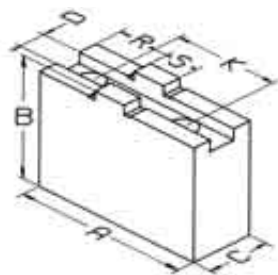

| Jaw Code | Dimensions (mm) |    |    |    |    |    |    | Bolt | Order Code               | List Price/1 | Offer Price/1 |
|----------|-----------------|----|----|----|----|----|----|------|--------------------------|--------------|---------------|
|          | A               | B  | C  | D  | K  | R  | S  |      |                          |              |               |
| CU16     | 85              | 40 | 20 | 8  | 32 | 25 | 18 | M8   | <b>KEN-490</b><br>-5740K | £20.25       | <b>£18.63</b> |
| CU20     | 105             | 51 | 22 | 10 | 40 | 34 | 20 | M8   | <b>-5760K</b>            | £24.00       | <b>£22.08</b> |
| CU25     | 125             | 55 | 30 | 12 | 40 | 36 | 20 | M12  | <b>-5780K</b>            | £33.95       | <b>£31.23</b> |

**Serrated Hard Jaws**

To suit Kitagawa serrated power chucks.

**3 Piece Set**

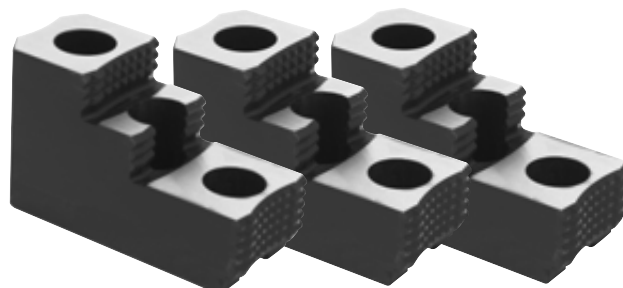
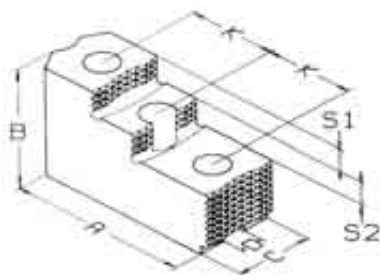

| Jaw Code | Chuck Diameter | Dimensions (mm) |    |    |    |    |    |    | Bolt     | Serrations               | Order Code | List Price/1   | Offer Price/1 |
|----------|----------------|-----------------|----|----|----|----|----|----|----------|--------------------------|------------|----------------|---------------|
|          |                | A               | B  | C  | D  | K  | S1 | S2 |          |                          |            |                |               |
| GT08     | 210mm          | 86              | 50 | 35 | 14 | 25 | 11 | 11 | 1.5 x 60 | <b>KEN-490</b><br>-6880K | £202.00    | <b>£185.84</b> |               |
| GT10     | 254mm          | 99              | 60 | 40 | 16 | 30 | 15 | 15 | 1.5 x 60 | <b>-6890K</b>            | £231.00    | <b>£212.52</b> |               |

**Serrated Soft Jaws**

To suit inch serrated power chucks (Berg, Forkardt, Rohm, Pratt Bernard, SMW and Autoblok etc).

**3 Piece Set**

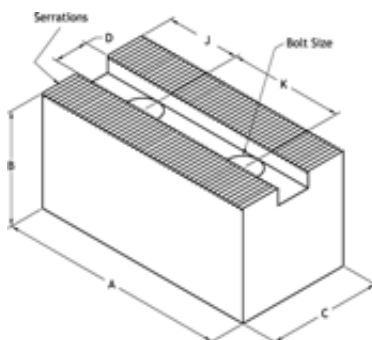

| Jaw Code | Chuck Diameter | Dimensions (mm) |    |    |      | K/J Bolt  | Serrations | Order Code               | List Price/1 | Offer Price/1 |
|----------|----------------|-----------------|----|----|------|-----------|------------|--------------------------|--------------|---------------|
|          |                | A               | B  | C  | D    |           |            |                          |              |               |
| BN70     | 165/200mm      | 70              | 60 | 40 | 17.0 | 22/15/M12 | 1/16" x 90 | <b>KEN-490</b><br>-5070K | £20.60       | <b>£18.95</b> |
| BN90     | 165/200mm      | 90              | 60 | 40 | 17.0 | 22/15/M12 | 1/16" x 90 | <b>-5090K</b>            | £23.30       | <b>£21.44</b> |
| BN12     | 250/315mm      | 120             | 80 | 50 | 21.0 | 28/20/M16 | 1/16" x 90 | <b>-5120K</b>            | £37.40       | <b>£34.41</b> |
| BN23     | 400/500/630mm  | 155             | 89 | 64 | 25.5 | 35/30/M20 | 3/32" x 90 | <b>-5230K</b>            | £80.95       | <b>£74.47</b> |

**Serrated Soft Jaws**

To suit inch serrated Coventry/Tudor manual chucks.

**3 Piece Set**

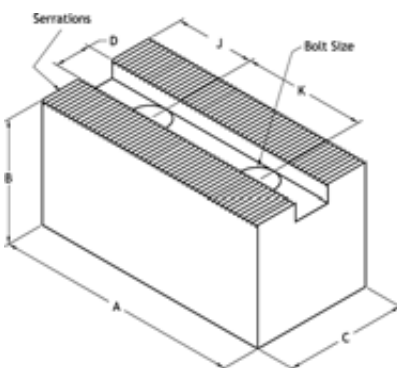

**Long Series jaws available on request**

| Jaw Code | Chuck Diameter | Dimensions (mm) |    |    |      | K/J Bolt           | Serrations | Order Code               | List Price/1 | Offer Price/1 |
|----------|----------------|-----------------|----|----|------|--------------------|------------|--------------------------|--------------|---------------|
|          |                | A               | B  | C  | D    |                    |            |                          |              |               |
| AJ06     | 6"/7.5"        | 57              | 32 | 25 | 12.7 | 12.7/16/ 5/16"BSW  | 1/16" x 90 | <b>KEN-490</b><br>-3060K | £14.80       | <b>£13.62</b> |
| AL06     | 6"/7.5"        | 67              | 50 | 25 | 12.7 | 12.7/16/ 5/16"BSW  | 1/16" x 90 | <b>-3560K</b>            | £18.95       | <b>£17.43</b> |
| AJ07     | 7.5"           | 64              | 32 | 25 | 14.3 | 17.5/21/ 3/8"BSW   | 1/16" x 90 | <b>-3070K</b>            | £18.10       | <b>£16.65</b> |
| AJ09     | 9"             | 70              | 44 | 32 | 15.9 | 15.9/21/ 7/16"BSW  | 1/16" x 90 | <b>-3090K</b>            | £23.30       | <b>£21.44</b> |
| AJ12     | 12"            | 76              | 51 | 38 | 17.5 | 23/19/ 1/2"BSW     | 1/16" x 90 | <b>-3120K</b>            | £27.75       | <b>£25.53</b> |
| AL12     | 12"            | 102             | 76 | 38 | 17.5 | 23/19/ 1/2"BSW     | 1/16" x 90 | <b>-3620K</b>            | £40.10       | <b>£36.89</b> |
| AJ15     | 15"            | 95              | 57 | 44 | 20.6 | 30.2/25.4/ 5/8"BSW | 1/16" x 90 | <b>-3150K</b>            | £41.10       | <b>£37.81</b> |
| AL15     | 15"            | 121             | 89 | 44 | 20.6 | 30.2/25.4/ 5/8"BSW | 1/16" x 90 | <b>-3650K</b>            | £61.30       | <b>£56.40</b> |
| AJ18     | 18"            | 108             | 65 | 50 | 25.4 | 34.9/27/ 3/4"BSW   | 3/32" x 90 | <b>-3180K</b>            | £61.80       | <b>£56.86</b> |
| AJ21     | 21"            | 140             | 80 | 50 | 25.4 | 41.3/43/ 3/4"BSW   | 3/32" x 90 | <b>-3210K</b>            | £80.50       | <b>£74.06</b> |
| AJ25     | 25"            | 159             | 80 | 50 | 25.4 | 54/41/ 3/4"BSW     | 3/32" x 90 | <b>-3250K</b>            | £89.10       | <b>£81.97</b> |

**CONTRACT PRICES AVAILABLE FOR VOLUME PURCHASES**

All Prices Exclude V.A.T. © 2011

Workshop Equipment

**GROUP 490 LATHE CHUCK JAWS**



To suit Howa and Kitagawa power chucks.



**D = Slot Width**

| Nut Code | Chuck Dia. (mm) | Type   | Slot Width | Bolt Size | Height | Order Code KEN-490 | List Price/1 | Offer Price/1 |
|----------|-----------------|--------|------------|-----------|--------|--------------------|--------------|---------------|
| GP03     | 110/135         | Double | 10         | M8 x 20   | 15.0   | -6600K             | £18.35       | £16.88        |
| GP05     | 135             | Double | 10         | M8 x 22   | 18.0   | -6620K             | £18.35       | £16.88        |
| GP06     | 165             | Double | 12         | M10 x 25  | 21.0   | -6630K             | £18.35       | £16.88        |
| GP07     | 165             | Double | 12         | M10 x 25  | 18.5   | -6640K             | £18.35       | £16.88        |
| GP08     |                 | Double | 14         | M12 x 30  | 23.0   | -6650K             | £20.30       | £18.68        |
| GP09     | 210             | Double | 14         | M12 x 30  | 20.5   | -6660K             | £20.30       | £18.68        |
| GP10     | 250             | Double | 16         | M12 x 30  | 23.0   | -6670K             | £22.30       | £20.52        |
| GP11     | 250             | Double | 16         | M12 x 30  | 21.5   | -6680K             | £21.80       | £20.06        |
| GR10     | 250             | Double | 16         | M12 x 35  | 26.5   | -6730K             | £23.50       | £21.62        |
| GP13     | 315             | Double | 21         | M16 x 35  | 28.0   | -6700K             | £27.20       | £25.02        |
| GP15     | 380             | Double | 22         | M20 x 55  | 45.5   | -6710K             | £42.80       | £39.38        |

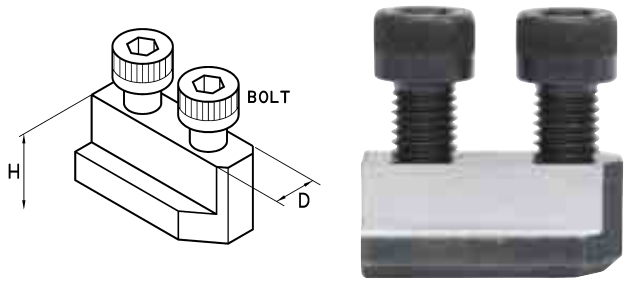

**T-Nuts**

For inch serrated chucks. To suit Forkardt, Geiger and Haarg, Pratt Burnard, Schunk and SMW power chucks.

**D = Slot Width**

| Nut Code | Chuck Dia. (mm) | Type   | Slot Width | Bolt Size | Height | Order Code KEN-490 | List Price/1 | Offer Price/1 |
|----------|-----------------|--------|------------|-----------|--------|--------------------|--------------|---------------|
| GN16     | 160/200/210     | Single | 17.0       | M12 x 30  | 23.0   | -6530K             | £8.30        | £7.64         |
| GN25     | 250/305/315     | Single | 21.0       | M16 x 35  | 27.0   | -6550K             | £10.95       | £10.07        |
| GN40     | 400/500/610     | Single | 25.5       | M20 x 40  | 11.0   | -6570K             | £14.65       | £13.48        |

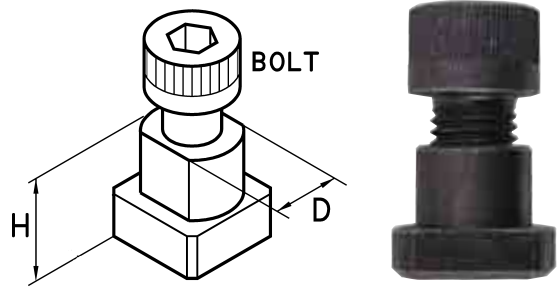

Workshop Equipment

**INDEXA Lathe Chuck Jaws**



For self-centring lathe chucks (IND-475) - Indexa 3200 and 3500. Chuck jaws supplied in sets of three.

**Hard Jaws**

| Chuck Dia (mm) | Weight per set | Order Code IND-490 |         | Offer Price/1 |
|----------------|----------------|--------------------|---------|---------------|
|                |                | Inside             | Outside |               |
| 80/85          | 132g           | -1210K             | -1010K  | £53.11        |
| 100            | 252g           | -1220K             | -1020K  | £61.12        |
| 125            | 561g           | -1230K             | -1030K  | £68.14        |
| 160            | 1166g          | -1250K             | -1050K  | £78.16        |
| 200            | 1627g          | -1260K             | -1060K  | £86.32        |
| 250            | 2604g          | -1270K             | -1070K  | £113.44       |
| 315            | 4120g          | -1280K             | -1080K  | £181.06       |

**Hard Jaws**

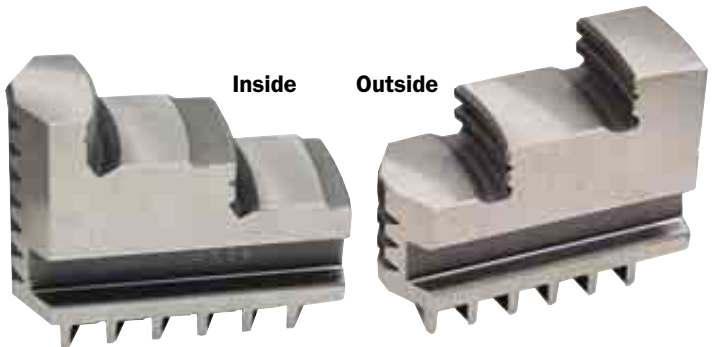

**Soft Jaws**

Sold individually.

**Soft Jaws**

| Chuck Dia (mm) | Weight | Order Code IND-490 | Offer Price/1 |
|----------------|--------|--------------------|---------------|
| 160            | 610g   | -2430K             | £13.62        |
| 200            | 609g   | -2440K             | £16.73        |
| 250            | 1061g  | -2450K             | £18.34        |
| 315            | 1857g  | -2460K             | £22.14        |

**Top**



**Lathe Chuck Keys**

Supplied as standard with all Indexa lathe chucks manufactured from high quality steel, ground finish body, sliding T-bar and spring return fitted to square drive. Suitable for use with all other makes of square drive adjusting lathe chucks.



| Square (AF) Size (mm) | Use With Chucks | Weight each | Order Code IND-490 | List Price/1 | Offer Price/1 |
|-----------------------|-----------------|-------------|--------------------|--------------|---------------|
| 6                     | 80              | 684g        | -5900K             | £19.28       | £17.74        |
| 7                     | 125/160         | 483g        | -5910K             | £19.60       | £18.03        |
| 9                     | 100/125         | 196g        | -5920K             | £25.94       | £23.86        |
| 11                    | 160/200         | 347g        | -5930K             | £26.72       | £24.58        |
| 14                    | 250/315         | 756g        | -5950K             | £31.07       | £28.58        |
| 17                    | 400             | 1356g       | -5970K             | £65.00       | £59.80        |
| 19                    | 500/630         | 1599g       | -5990K             | £71.16       | £65.47        |

**KENNEDY** *Huntington Type Wheel Dressers*  
QUALITY INDUSTRIAL TOOLING

With improved quick release cutter wheel design which reduces down-time when changing wheels. Ergonomically designed cast iron handle and case hardened, polished cutters. Suitable for cleaning, sharpening and truing grinding wheels.



| Type | For Wheel Diameter | Weight each | Order Code <b>KEN-495</b> | List Price/1 | Offer Price/1 |
|------|--------------------|-------------|---------------------------|--------------|---------------|
| No.0 | Up to 510mm (20")  | 0.85kg      | <b>-0100K</b>             | £18.94       | <b>£15.15</b> |
| No.1 | Up to 760mm (30")  | 1.00kg      | <b>-0110K</b>             | £24.31       | <b>£19.45</b> |
| No.2 | Over 760mm (30")   | 2.50kg      | <b>-0120K</b>             | £34.83       | <b>£27.86</b> |



**Replacement Wheel Sets**



| Description                | Weight per 10 Sets | Order Code <b>KEN-495</b> | List Price/1 | Offer Price/1 |
|----------------------------|--------------------|---------------------------|--------------|---------------|
| Spare Wheels for Type No.0 | 0.45kg             | <b>-1000K</b>             | £2.19        | <b>£1.75</b>  |
| Spare Wheels for Type No.1 | 0.53kg             | <b>-1010K</b>             | £2.41        | <b>£1.93</b>  |
| Spare Wheels for Type No.2 | 2.90kg             | <b>-1020K</b>             | £5.54        | <b>£4.43</b>  |

**Replacement Parts**

| Description                 | Weight per 10 | Order Code <b>KEN-495</b> | List Price/10 | Offer Price/10 |
|-----------------------------|---------------|---------------------------|---------------|----------------|
| Side Bush for Type No.0     | 79g           | <b>-2000K</b>             | £7.19         | <b>£5.75</b>   |
| Cutter Bush for Type No.1   | 110g          | <b>-2010K</b>             | £7.56         | <b>£6.05</b>   |
| Cutter Bush for Type No.2   | 234g          | <b>-2020K</b>             | £10.75        | <b>£8.60</b>   |
| Spare Spindle for Type No.0 | 130g          | <b>-3000K</b>             | £5.18         | <b>£4.14</b>   |
| Spare Spindle for Type No.1 | 310g          | <b>-3010K</b>             | £12.88        | <b>£10.30</b>  |
| Spare Spindle for Type No.2 | 310g          | <b>-3020K</b>             | £15.75        | <b>£12.60</b>  |
| Side Washer for Type No.1   | 70g           | <b>-4010K</b>             | £6.87         | <b>£5.50</b>   |
| Side Washer for Type No.2   | 50g           | <b>-4020K</b>             | £7.50         | <b>£6.00</b>   |

**Diamond Point Wheel Dressing Tools**

**Single-Point Tools**

For general use. The diamond point can be reset when it 'flats', giving extended tool life (resetting prices available on request). 1/2" x 6" holder size.



| Product Number | Diamond Size, Carat | For use on Wheel | Weight each | Order Code <b>KEN-496</b> | List Price/1 | Offer Price/1 |
|----------------|---------------------|------------------|-------------|---------------------------|--------------|---------------|
| SP50           | 0.50                | 180mm (7")       | 160g        | <b>-0050K</b>             | £20.55       | <b>£15.82</b> |
| SP75           | 0.75                | 255mm (10")      | 160g        | <b>-0070K</b>             | £31.37       | <b>£24.15</b> |
| SP100          | 1.00                | 355mm (14")      | 170g        | <b>-0100K</b>             | £43.25       | <b>£33.30</b> |
| SP150          | 1.50                | 460mm (18")      | 170g        | <b>-0150K</b>             | £61.64       | <b>£47.46</b> |
| SP200          | 2.00                | 600mm (24")      | 170g        | <b>-0200K</b>             | £82.19       | <b>£63.29</b> |

**Multi-Point Tools**

Designed to give constant exposure of diamond edges and points, ensuring a consistent, smooth dressing action. Directly replaces single point tools (above) but without the need for resetting due to point wear.



| Product Number | Head Size Dia x Length | Suitable for Wheels up to | Weight each | Order Code <b>KEN-496</b> | List Price/1 | Offer Price/1  |
|----------------|------------------------|---------------------------|-------------|---------------------------|--------------|----------------|
| MAR 250        | 3/8" x 7/16"           | 255mm (10")               | 78g         | <b>-0510K</b>             | £60.32       | <b>£51.88</b>  |
| MARH500        |                        |                           | 82g         | <b>-0520K</b>             | £81.30       | <b>£69.92</b>  |
| MAR 500        | 1/2" x 1/2"            | 510mm (20")               | 147g        | <b>-0530K</b>             | £95.22       | <b>£81.89</b>  |
| MARH500        |                        |                           | 152g        | <b>-0540K</b>             | £132.00      | <b>£113.52</b> |

**Chisel-Point Tools**

Designed for dressing formed wheels. Similar to single point tools but more robust and no resetting required. 3/8" x 3" holder size.



| Product Number | Included Angle | Nose Radius | Weight each | Order Code <b>KEN-496</b> | List Price/1 | Offer Price/1 |
|----------------|----------------|-------------|-------------|---------------------------|--------------|---------------|
| D605           |                | 0.005"      | 160g        | <b>-1000K</b>             | £84.72       | <b>£72.86</b> |
| D6010          | 60°            | 0.010"      | 160g        | <b>-1010K</b>             | £77.34       | <b>£66.51</b> |
| D6020          |                | 0.020"      | 160g        | <b>-1020K</b>             | £86.55       | <b>£74.43</b> |
| D405           |                | 0.005"      | 170g        | <b>-1100K</b>             | £84.72       | <b>£72.86</b> |
| D4010          | 40°            | 0.010"      | 170g        | <b>-1110K</b>             | £84.72       | <b>£72.86</b> |
| D4020          |                | 0.020"      | 170g        | <b>-1120K</b>             | £86.55       | <b>£74.43</b> |

**SENATOR** *Diamond Dressers*  
QUALITY TOOLING

For truing and dressing grinding wheels. Truing is the process of aligning the periphery of the grinding wheel so that it runs concentric with its axis of rotation. This allows accurate and precise relative motion between the grinding wheel and the part being ground. Dressing removes dulled abrasives and foreign material that has been embedded into the wheel. This allows the wheel to cut properly. These tools are mainly used to true straight-faced wheels.

**3 Piece Set**

For medium-duty use. 1/2" dia. x 6" (-9100K).



| Wheel Size (mm)                     | Carat Size | Weight each | Order Code <b>SEN-496</b> | List Price/1 | Offer Price/1 |
|-------------------------------------|------------|-------------|---------------------------|--------------|---------------|
| Up to 150                           | 0.25       | 149g        | <b>-0250K</b>             | £5.10        | <b>£3.52</b>  |
| Up to 180                           | 0.50       | 150g        | <b>-0500K</b>             | £9.27        | <b>£6.40</b>  |
| Up to 250                           | 0.75       | 150g        | <b>-0750K</b>             | £14.76       | <b>£10.18</b> |
| Up to 350                           | 1.00       | 151g        | <b>-1000K</b>             | £19.52       | <b>£13.47</b> |
| Up to 500                           | 1.50       | 149g        | <b>-1500K</b>             | £27.81       | <b>£19.19</b> |
| Up to 600                           | 2.00       | 150g        | <b>-2000K</b>             | £38.93       | <b>£26.86</b> |
| 3 Piece Set 0.5, 0.75 & 1 Carat Set |            |             | <b>-9100K</b>             | £45.44       | <b>£24.54</b> |

**CONTRACT PRICES AVAILABLE FOR VOLUME PURCHASES**

All Prices Exclude V.A.T. © 2011